

General Information

- Available in 250-500 and 1000-2000 series.
- Monorail portion requires additional threaded rod drops for support.
- Minimize both monorail and bridge cantilevers to reduce deflection. Deflection makes passing between bridge and monorail more difficult.
- Use anti-kick up end trucks on bridge opposite interlock.
- Use two (2) clamping end trucks on bridge. End truck nearest interlock to be clamped tightly and end truck opposite end truck to be allowed to slip. Clamping screws on end truck opposite interlock serve to limit travel of rail inside end truck sleeve.
- Field welding is required for installation.
- 3/32" gap is required between bridge and monorail tracks.
- Bridge track flange to be installed 1/16" above monorail track flange elevation.
- Request hoist dimensions to check clearance to interlock components.
- The runway and bridge must be forced to deflect vertically at the same rate as the monorail. Therefore, the hanger assembly supporting the interlock on the monorail **must** be tied directly to the runway of the bridge crane at the point of load transfer. Failure to do this will result in an inoperable interlock assembly.

Process for an Interlock Order

1. Position bridge and monorail track sections per Figure 1.

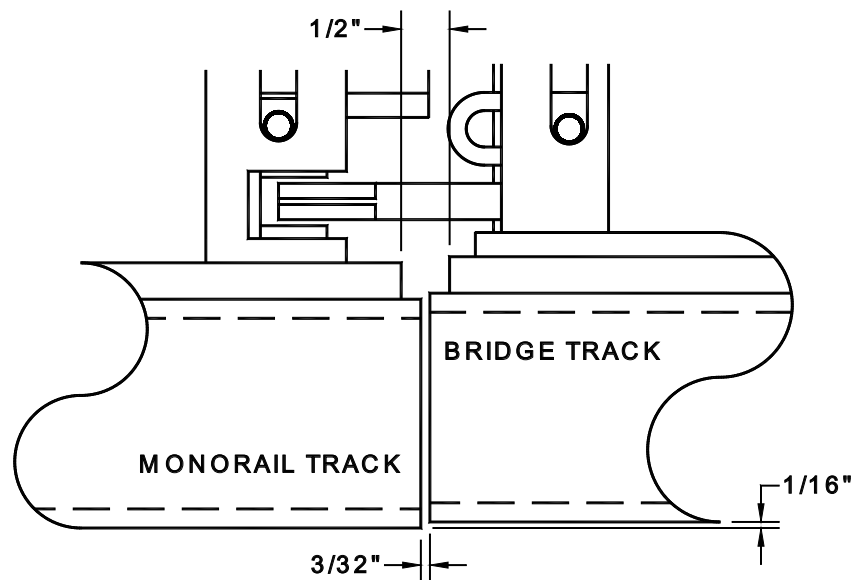
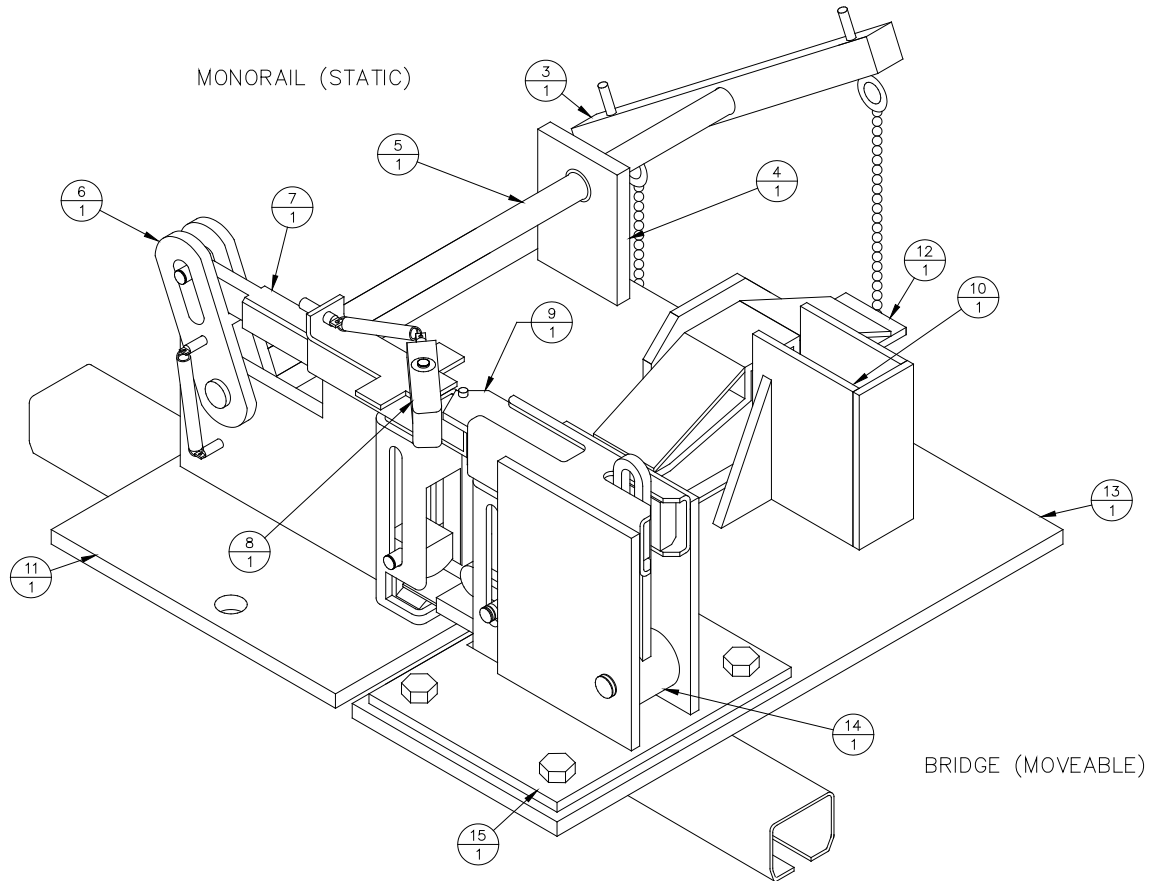

Figure 1.

2. Install monorail and bridge assemblies by the following sequence of steps. For additional dimensions refer to the interlock general arrangement drawing.
 - A. Clamp monorail and bridge assemblies to their respective tracks. Two hangers are required to support the monorail interlock assembly.
 - B. Insure adequate clearance and proper position when interlocking bridge to monorail and when bypassing (moving bridge past monorail without interlocking). Shimming of assemblies may be required.
 - C. Weld monorail and bridge assemblies to their respective tracks, using E70XX electrode wire, in accordance with AWS D14.1 specifications.



| ITEM | DESCRIPTION | ITEM | DESCRIPTION |
|------|--------------------------|------|-------------------------|
| 1 | Monorail Door | 9 | Bridge Shot Pin |
| 2 | Bridge Door | 10 | Alignment Arm Assembly |
| 3 | Actuator Arm Assembly | 11 | Monorail Mounting Plate |
| 4 | Actuator Bearing Bracket | 12 | Alignment Ramp |
| 5 | Actuator Shaft | 13 | Bridge Mounting Plate |
| 6 | Clevis Arm | 14 | Bridge Door Lever |
| 7 | Monorail Shot Pin | 15 | Bridge Door Weldment |
| 8 | Monorail Shot Pin Lock | | |

Sequence of Operations for Bridge to Monorail Interlock

1. With the bridge more than four (4) inches away from the monorail spur, the operator pulls down on the black, T-shaped knobbed bridge alignment chain, until the stop is hit, and holds the chain at this level. This will lower the alignment lock block below the level of the alignment locking ramp.
2. When the bridge is within four (4) inches of the monorail spur the operator releases the black, T-shaped knobbed bridge alignment chain. The alignment lock block is now sliding on the alignment locking ramp and will be automatically locked in position once the operator tries to move the bridge by the monorail spur. Once locked, the primary shot pin will be aligned with the secondary shot pin.
3. The operator pulls on the red, round knobbed monorail chain until the stop is hit. This pushes the primary (monorail) shot pin forward which pushes the secondary (bridge) shot pin forward, rotating a linkage arm, which in turn lifts the bridge trolley stop.
4. As the bridge trolley stop rises, a linkage lifts the monorail trolley stop.
5. The operator can now move the trolley from the bridge to the monorail spur or vice versa.
6. When the operator has completed the transfer, pulling on the black, round knobbed monorail chain will pull the primary shot pin back into its original position. The primary shot pin automatically pulls the secondary shot pin. This action reverses the linkage motion described above, lowering the bridge and monorail trolley stops.
7. The trolley stops are designed so that if a trolley or modified load bar is not completely onto the bridge or monorail then the trolley stops will not lower and the interlock remains locked.
8. To complete the disengagement on the bridge from the monorail spur, the operator pulls on the black, T-shaped knobbed bridge alignment chain, until the stop is hit, and while holding the chain at this level moves the bridge away from the monorail spur. When the bridge is at least four (4) inches away from the monorail spur, the operator can release the black knobbed alignment chain.
9. This system as described above does not automatically index as bridge passes monorail spur.

Interlock Performance Criteria

1. The trolley stops are to remain closed at all times when no interlock function is being performed.
2. Should be able to impact trolley stops, with trolley, at any time without trolley stops opening.
3. When bridge crane is within 4 inches of monorail spur, interlock function can be performed in a time frame not to exceed 10 seconds.
4. Crane transfer does not “latch in” to monorail transfer unless interlock function is required. (Crane can pass by monorail without being manually indexed.)
5. Actuating mechanism to be “clean and uncomplicated”. Overhead actuating chains should be kept to a minimum to reduce operator confusion.
6. Interlocks can't be separate until both trolleys (for load bar applications) are either fully on monorail spur, or bridge, and 2-3 inches away from end of track.
7. Based on this design, trolley needs to be a minimum of 2-3 inches away from end of bridge and/or monorail when interlocking is performed.
8. Actuating arm to be offset from the centerline of the track 6 inches so that the hoist will not interfere with the actuating chains.

Note: Runways are not intended for side loading. End user should take the necessary steps to ensure that this condition is not present.

Modifications Interlocks

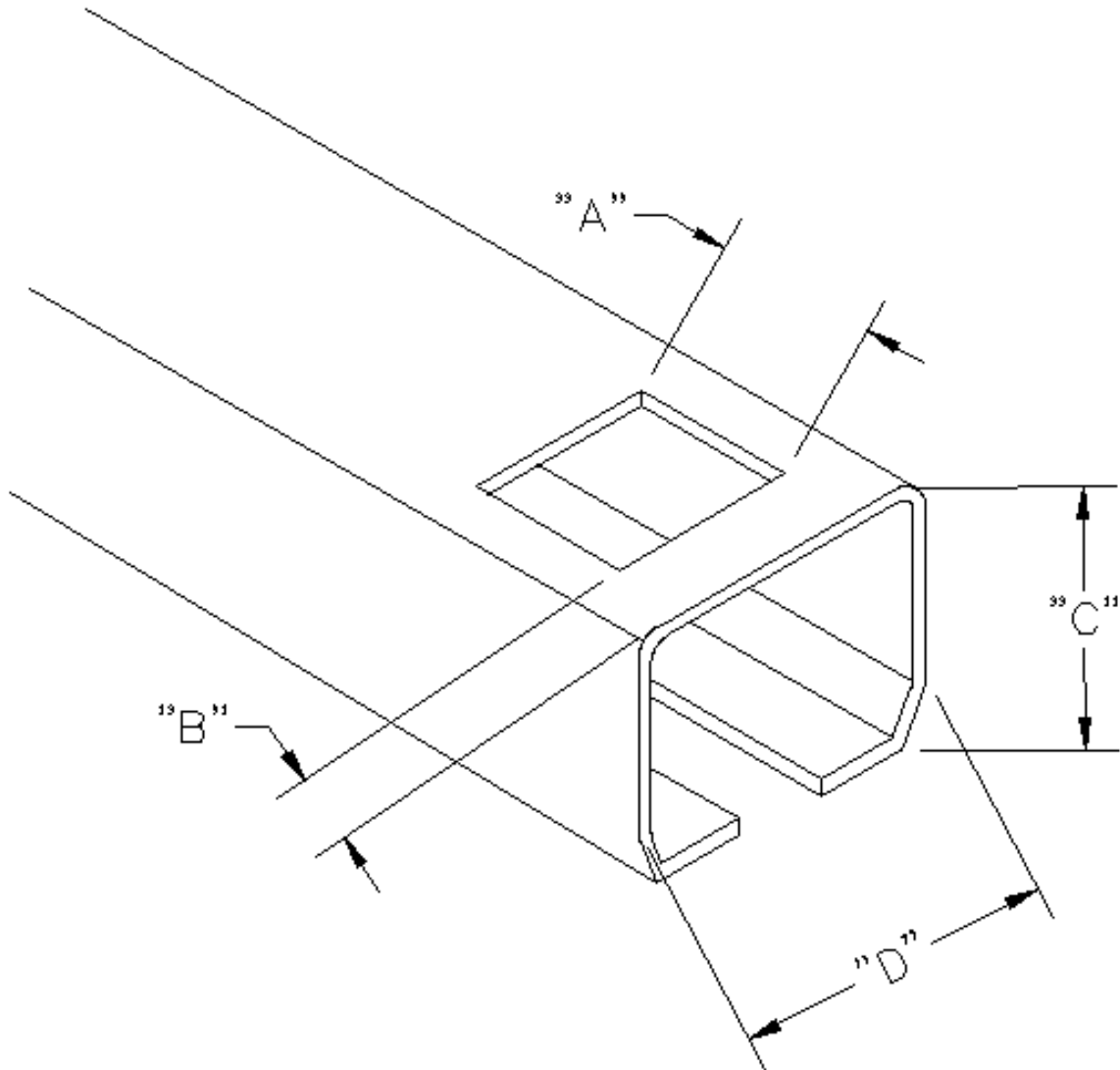

A = 1 3/4" Sq.

B = 9/16"

C = 2 3/8"

D = 2 9/16"

GORBEL[®]
A C L A S S A B O V E

www.gorbel.com
Phone: (585) 924-6262
Toll Free Phone: (800) 821-0086
© 2012 Gorbel Inc.
All Rights Reserved