

Motorized Wall Bracket Jib Crane

Installation, Operation & Maintenance Manual

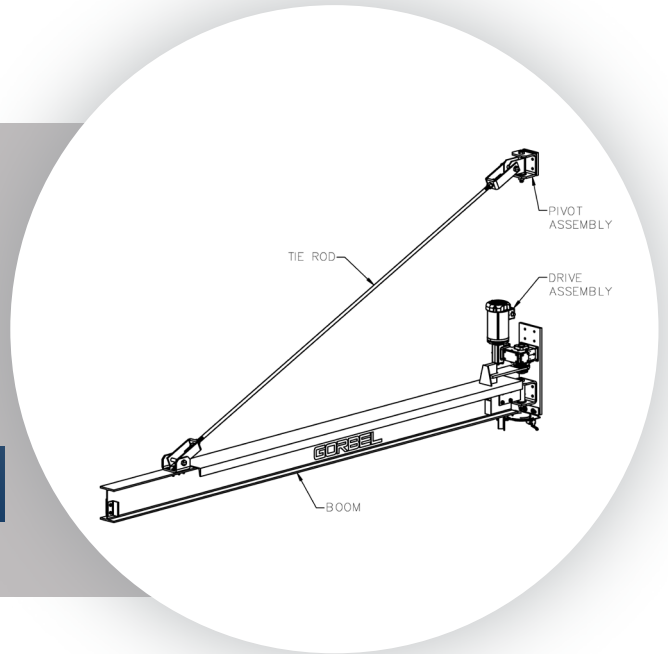

**IMPORTANT!
DO NOT DESTROY**

Register Your
Warranty



Gorbel[®] Customer Order No. / Serial No.

Gorbel[®] Dealer

Date (Month - Year)

Table of Contents

Introduction	1
Installation.....	2
Step 1 - Pre-Assembly.....	2
Step 2 - Drive Installation.....	5
Step 2 - Drive Installation (Clutch).....	6
Step 3 - Boom Installation	7
Step 4 - Electrification Installation.....	10
Step 5 - Endstop / Tagline Installation.....	11
Step 6 - ACM	12
Step 7 - Limit Switch Installation	13
Step 8 - Accessories (Optional).....	15
Step 9 - Final Steps	15
Shut-Down Instructions.....	16
Safety Warnings and Precautions	16
Troubleshooting Guide.....	17
Appendix A: Securex Friction Torque Limiter Type C & T	18
Crane Operator Instructions	22
Limited Warranty.....	23
Maintenance Schedule	24
Lubrication Schedule	24

 **WARNING**

This product contains chemicals known to the State of California to cause cancer and birth defects or other reproductive harm.

For more information: www.P65Warnings.ca.gov

Gorbel Inc.
600 Fishers Run, P.O. Box 593
Fishers, NY 14453-0593
Telephone: (800) 821-0086
(585) 924-6262
Fax: (800) 828-1808

Introduction

Thank you for choosing a Gorbel® Motorized Wall Bracket jib crane to solve your material handling needs. The innovative design and heavy-duty construction of a Gorbel® motorized jib crane will provide a superior quality product that will offer years of long term value. All Gorbel® cranes are pre-engineered for powered hoist operation. The hoist weight allowance is 15% of the crane capacity (for example, a crane rated for 1000 pounds allows for a 1000-pound live load plus 150 pounds for the weight of the hoist). There is also an allowance of 25% of the crane capacity for impact caused by hoist use. Gorbel® motorized jib cranes will provide many years of dependable service by following the installation and maintenance procedures described herein.

Dimensions contained in this installation manual are for reference only and may differ for your particular application.

Normal safety precautions: These include, but are not limited to:

- Checking for all obstructions in crane rotation
- Checking that all bolts are tight and have lockwashers
- Making sure that endstops are in place
- Making sure that festooning cannot be snagged or pinched

For additional safety precautions, see page 16.



WARNING: Only competent erection personnel familiar with standard fabrication practices should be employed to assemble these cranes because of the necessity of properly interpreting these instructions. Gorbel is not responsible for the quality of workmanship employed in the installation of a crane according to these instructions. Contact Gorbel, Inc., at 600 Fishers Run, P.O. Box 593, Fishers, New York 14453-0593, 1-800-821-0086, for any additional information if necessary.



WARNING: Equipment described herein is not designed for, and should not be used for, lifting, supporting or transporting humans. Failure to comply with any one of the limitations noted herein can result in serious bodily injury and/or property damage. Check State and Local regulations for additional requirements.



WARNING: Consult a qualified structural engineer to determine if your support structure is adequate to support the thrust and pull forces of your crane.



WARNING: Crane cannot be utilized as a ground: A separate ground wire is required. For example, systems with 3-phase power require 3 conductors plus one ground wire.



WARNING: Reference American Institute of Steel Construction (AISC) manual of Steel Construction (9th edition), Part 5, Specification for Structural Joints using ASTM A325 or A490 Bolts (section 8.d.2) for proper procedures to follow when using any torque tightening method.



WARNING: Do not field modify crane in any way. Any modifications without the written consent of Gorbel, Inc. will void warranty.



WARNING: Storing and/or using your Gorbel equipment outside, when it is not specifically designed for such, may void all or part of the product warranty. Always store/use product(s) as designed.

Installation

Step 1 - Pre-Assembly

TIP: Packing list can be found in plastic pocket inside hardware box.

- 1.1 Read entire manual **before** beginning installation of crane.
- 1.2 Check packing list to ensure no parts have been lost prior to initializing assembly of crane.
- 1.3 Tools and materials (by others) often needed to assemble crane are as follows:
 - Torque wrench
 - Open end wrench or Allen key for clutch
 - Steel shims
 - Leveling tools and plumb bob
 - Mounting hardware (by others, grade 5 bolts or better)
 - Hand tools
 - Ladders / Man Lifts
 - Lifting device to lift heavy booms
- 1.4 Determine:
 - Thrust and pull (**diagram 1A** below, **chart 1A** on page 3, and the **General Arrangement Drawing**)



WARNING: Consult a qualified structural engineer to determine if your support structure is adequate to support the loads generated by the thrust and pull of your crane.

- Bracket centers (**chart 1A**, page 3).
- Bolt pattern and dimensions for fittings (**diagrams 1B** and **1C** and **chart 1B**, page 4).
- Bolt pattern for mounting plates (**Mounting Detail drawing**).

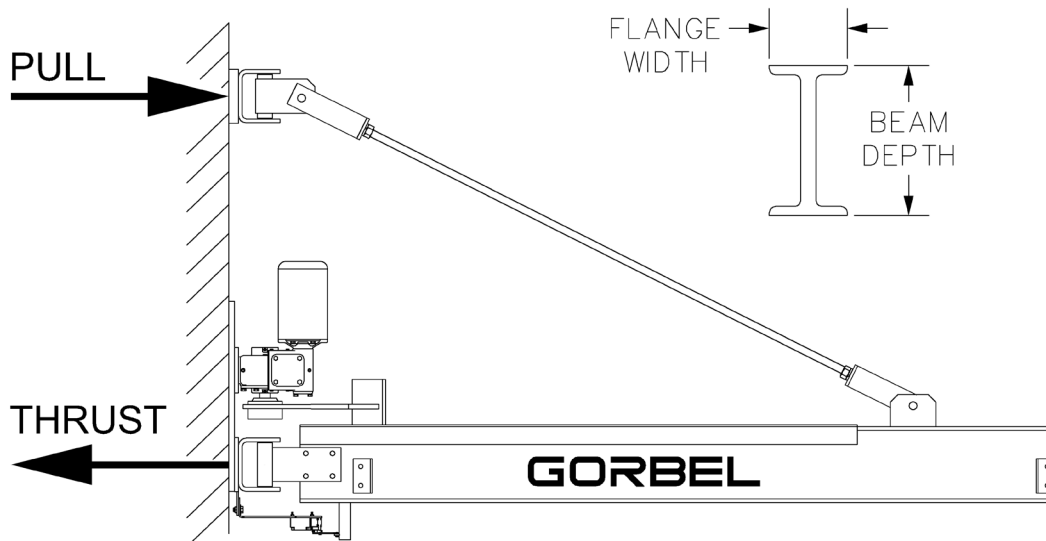
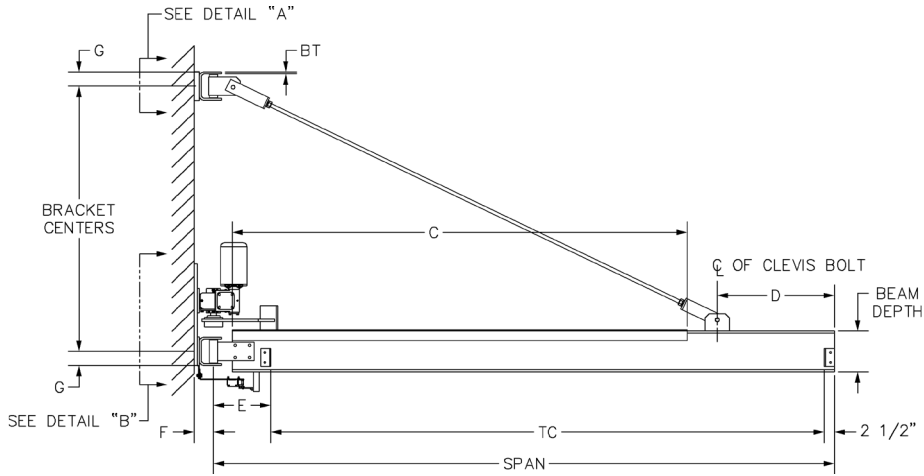

Diagram 1A. Thrust and pull definition.

Capacity (tons)	Span	Bracket Type	Bracket Centers	D	Beam Depth	C = Cap Channel Length	Tie Rod Diameter & Thread	Tie Rod Length	W - Beam Length	Thrust & Pull (lbs.)	
1/2	8'	WB-G1	2'-9"	1'-3"	W6	9'-0"	1"-8UNC	5'-10 1/4"	7'-7 3/8"	3703	
	10'		3'-0"	1'-6"	W6			7'-7 1/4"	9'-7 3/8"	4400	
	12'		3'-9"	1'-9"	W6c10			9'-6"	11'-7 3/8"	4337	
	14'		4'-6"	2'-0"	W6c10			10'-9"	11'-4 3/4"	13'-7 3/8"	4306
	16'		5'-6"	2'-0"	W6c10			12'-9"	13'-7 1/2"	15'-7 3/8"	4097
	18'		6'-0"	2'-0"	W8c10			14'-9"	15'-8"	17'-7 3/8"	4453
	20'		6'-6"	2'-3"	W8c10			16'-6"	17'-5 1/2"	19'-7 3/8"	4646
	22'		7'-0"	2'-3"	W8c10			18'-9"	19'-6 1/4"	21'-7 3/8"	4822
	24'		7'-6"	2'-6"	W8c10			20'-6"	21'-4"	23'-7 3/8"	4985
	26'		8'-0"	2'-6"	W10c10			22'-6"	23'-4 1/2"	25'-7 3/8"	5474
	28'		9'-0"	3'-0"	W10c10			24'-0"	25'-1 1/4"	27'-7 3/8"	5332
	30'		10'-0"	3'-6"	W10c10			25'-6"	26'-10"	29'-7 3/8"	5230
1	8'	WB-G1	2'-9"	1'-3"	W6	9'-0"	1"-8UNC	5'-10 1/2"	7'-7 3/8"	7267	
	10'		3'-0"	1'-6"	W6			7'-7 1/4"	9'-7 3/8"	8600	
	12'		3'-9"	1'-9"	W6c10			9'-6"	11'-7 3/8"	8444	
	14'		4'-6"	2'-0"	W8c10			10'-9"	11'-4 3/4"	13'-7 3/8"	8481
	16'		5'-6"	2'-3"	W8c10			12'-6"	13'-4 1/2"	15'-7 3/8"	8055
	18'		6'-0"	2'-6"	W8c10			14'-3"	15'-2 1/4"	17'-7 3/8"	8419
	20'		6'-6"	2'-6"	W10c10			16'-3"	17'-2 1/2"	19'-7 3/8"	8985
	22'		7'-0"	2'-9"	W10c10			18'-3"	19'-1/4"	21'-7 3/8"	9299
	24'		7'-6"	2'-9"	W10c10			20'-3"	21'-1"	23'-7 3/8"	9585
	26'		8'-0"	3'-0"	W10c10			22'-0"	22'-10 3/4"	25'-7 3/8"	9848
	28'		9'-0"	3'-6"	W12c10			23'-6"	24'-7 1/4"	27'-7 3/8"	9924
	30'		10'-0"	3'-6"	W12c10			25'-6"	26'-10"	29'-7 3/8"	9695
2	8'	WB-G2	2'-9"	1'-3"	W6	9'-0"	1 1/2"-6UNC	5'-11 1/4"	7'-7 1/4"	14394	
	10'		3'-0"	1'-6"	W8			7'-8 1/4"	9'-7 1/4"	17100	
	12'		3'-9"	1'-9"	W8c10			9'-7"	11'-7 1/4"	16772	
	14'		4'-6"	2'-0"	W8c10			10'-9"	11'-5 3/4"	13'-7 1/4"	16570
	16'		5'-6"	2'-3"	W10c10			12'-6"	13'-5"	15'-7 1/4"	15878
	18'		6'-0"	2'-3"	W10c10			14'-6"	15'-5 3/4"	17'-7 1/4"	16569
	20'		6'-6"	2'-6"	W12c10			16'-3"	17'-3 1/4"	19'-7 1/4"	17446
	22'		7'-0"	2'-6"	W12c10			18'-6"	19'-4"	21'-7 1/4"	18010
	24'		7'-6"	3'-0"	W12c10			20'-0"	20'-11"	23'-7 1/4"	18517
	26'		8'-0"	3'-6"	W12c10			21'-6"	22'-3"	25'-7 1/4"	18979
	28'		9'-0"	3'-6"	W10c10			23'-6"	24'-5"	27'-7 1/4"	17932
	30'		10'-0"	3'-0"	W12c10			26'-0"	27'-4 3/4"	29'-7 1/4"	17815
3	8'	WB-G3	2'-9"	1'-3"	W8	9'-0"	1 1/2"-6UNC	5'-11 1/2"	7'-6 5/8"	18270	
	10'		3'-3"	1'-6"	W8			7'-9 1/2"	9'-6 5/8"	23538	
	12'		4'-0"	1'-9"	W10c10			9'-8"	11'-6 5/8"	23568	
	14'		4'-9"	2'-0"	W10c10			10'-9"	11'-6 3/4"	13'-6 5/8"	23526
	16'		5'-6"	2'-3"	W10c10			12'-6"	13'-5 1/2"	15'-6 5/8"	23514
	18'		6'-3"	2'-3"	W12c10			14'-6"	15'-6 3/4"	17'-6 5/8"	23755
	20'		7'-0"	2'-6"	W12c10			16'-6"	17'-5 1/2"	19'-6 5/8"	23800
	22'		7'-9"	2'-6"	W12c10			18'-6"	19'-7 1/4"	21'-6 5/8"	23854
	24'		8'-6"	3'-0"	W12c10			20'-0"	21'-3 1/4"	23'-6 5/8"	23915
	26'		9'-3"	3'-0"	W12c10			22'-0"	23'-4 3/4"	25'-6 5/8"	23982
	28'		10'-0"	3'-0"	W12c10			24'-0"	25'-6 1/2"	27'-6 5/8"	24052
	30'		11'-0"	3'-0"	W12c10			26'-0"	27'-9"	29'-6 5/8"	23577
5	8'	WB-G5	3'-0"	1'-6"	W8	9'-0"	2"-4 1/2UNC	5'-9 3/4"	7'-6 5/8"	28165	
	10'		3'-3"	1'-6"	W10			7'-9 1/2"	9'-6 5/8"	36371	
	12'		4'-0"	1'-9"	W10c12			10'-9"	9'-8 1/4"	11'-6 5/8"	38968
	14'		4'-9"	2'-0"	W12c12			12'-3"	11'-7"	13'-6 5/8"	39038
	16'		5'-6"	2'-6"	W12c12			12'-3"	13'-2 1/2"	15'-6 5/8"	38996
	18'		6'-3"	3'-0"	W12c12			13'-9"	14'-10 1/2"	17'-6 5/8"	38987
	20'		7'-0"	3'-6"	W16c12			15'-3"	16'-6 1/2"	19'-6 5/8"	39286
	22'		7'-9"	3'-6"	W18c12			17'-3"	18'-8"	21'-6 5/8"	39497
	24'		8'-6"	3'-6"	W12c12			19'-3"	20'-3 3/4"	23'-6 5/8"	37952
	26'		9'-3"	3'-6"	W16c12			21'-3"	22'-11 1/4"	25'-6 5/8"	39482
	28'		10'-0"	3'-6"	W16c12			23'-3"	25'-1"	27'-6 5/8"	39564
	30'		11'-0"	3'-6"	W16c12			25'-3"	27'-2 3/4"	29'-6 5/8"	38750

Chart 1A.



C = Cap Channel

TC (trolley coverage (distance between endstops)) = Span - (E + 2 1/2")

Diagram 1B.

	E	F	G	BT (Brkt. Thk.)
WB-G1	14 1/8"	4 1/4"	3 1/2"	1/2"
WB-G2	13 3/4"	4 3/4"	4 1/8"	5/8"
WB-G3	14 1/8"	4 3/4"	4 5/8"	3/4"
WB-G5	15 3/8"	6 3/4"	7"	1"

Chart 1B.

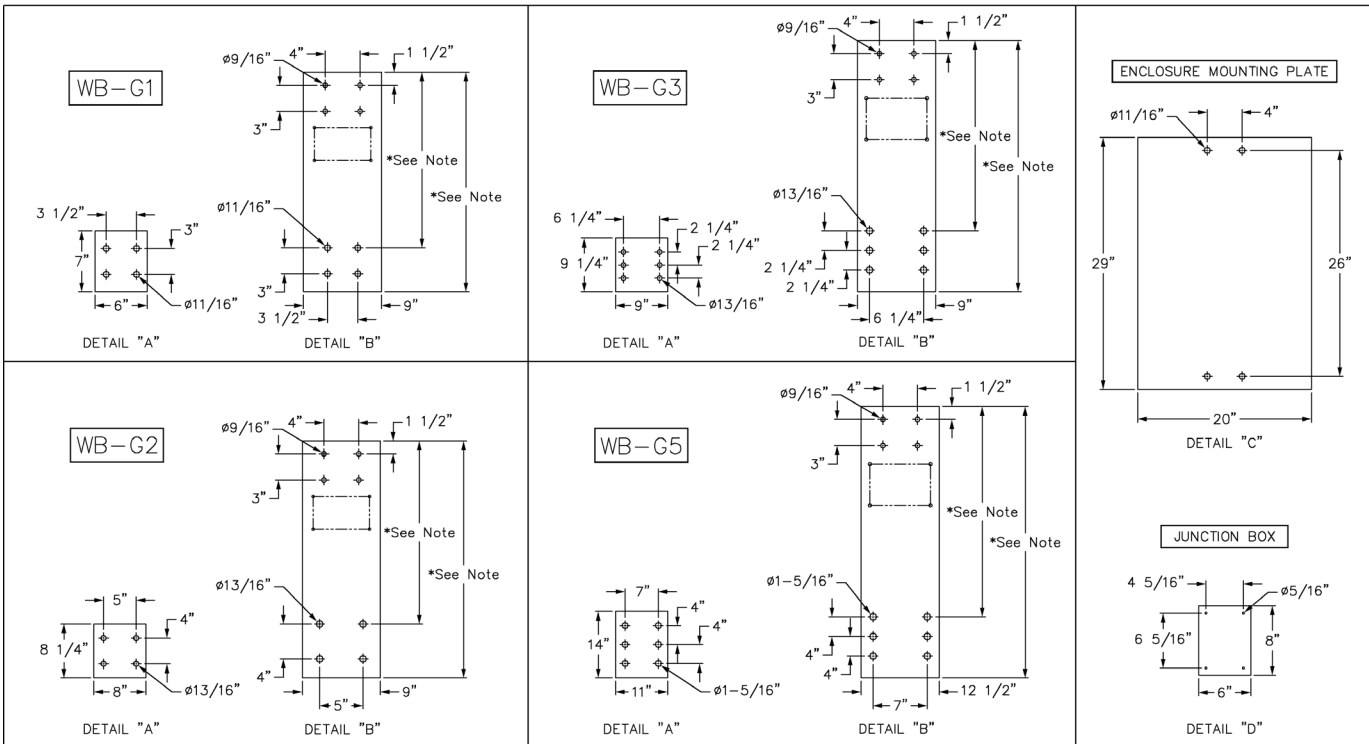

Diagram 1C.

NOTE: Dimensions may vary depending on the reducer size. For exact dimensions please consult Gorbels® Customer Service at 800-821-0086.

Step 2 - Drive Installation

TIP: Use caution to support the drive components during assembly and adjustment.

- 2.1 Drive assembly is bolted to main mounting plate and shipped together by Gorbel. Spacer plates (where required) are shipped loose. Refer to Steps 3.1 and 3.2.
- 2.2 The clutch is pre-tightened by Gorbel. If any additional clutch adjustment is required, refer to the friction clutch instructions on page 6. If the clutch is not tightened properly, the lever arm may slip and the crane may not rotate properly.
- 2.3 Locate the desired drive mounting location on support structure. Ensure that mounting surface of support structure is plumb between area of where upper and lower pivot assemblies will be mounted. Level drive mounting plate and locate and drill holes.
- 2.4 Bolt drive plate to support structure using the four (4) holes at the top of the plate (**diagram 2A**). Hardware by others (should be grade 5 or better).

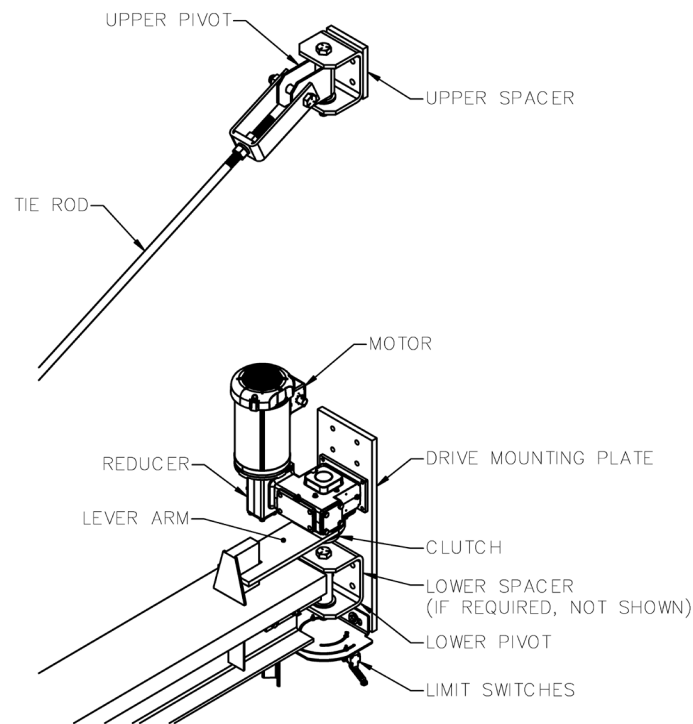

Diagram 2A.

Step 2 - Drive Installation (Clutch)

STOP! If your crane was purchased prior to 2021, refer to the instructions below. For cranes purchased since 2021, go to Appendix A on page 18.

TIP: The friction clutch is shipped **pretightened** by Gorbel. If the clutch begins to slip during initial use, **within the rated capacity of the crane**, allow the clutch to slip several times then re-tighten the clutch per the instructions below. The purpose for allowing the clutch to slip several times is to establish a uniform surface on the friction linings.

Friction Clutch

During normal operation, adjustment to compensate for friction lining wear may be necessary. The frequency of these adjustments will be dependent on the frequency of overloads occurring.

The clutch torque adjustment method is dependent on the clutch type which is determined by whether the crane is used indoors (without a wind load) or outdoors (with a wind load).

CLUTCH TORQUE ADJUSTMENT - CRANES USED INDOORS

Loosen the locking screw on the adjusting nut. Using the hook wrench provided, turn the adjusting nut counterclockwise until the drive sprocket can turn freely in the clutch. The clutch can now be re-tightened to the proper torque setting. Turn the adjusting nut clockwise until it is hand tight. Using the hook wrench provided, tighten the adjusting nut an additional two full revolutions. After the adjustment is made, tighten the locking screw to ensure that the adjusting nut doesn't loosen. The proper torque setting is achieved when the drive sprocket will not slip under **normal** operating conditions (**diagram 2C**).

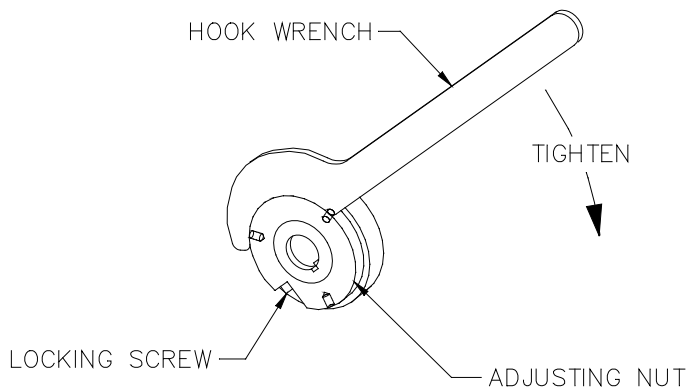

Diagram 2C. Indoor Clutch Torque Adjustment.

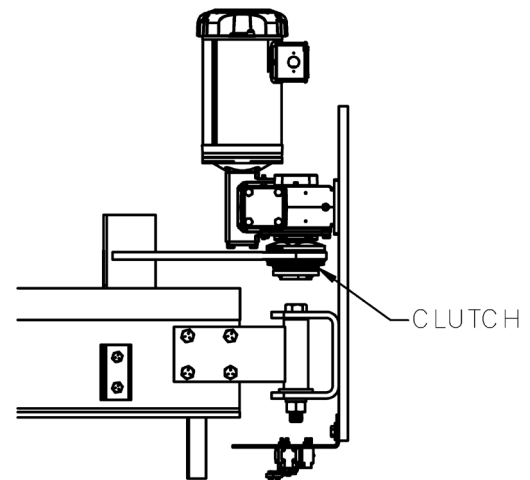

Diagram 2B.

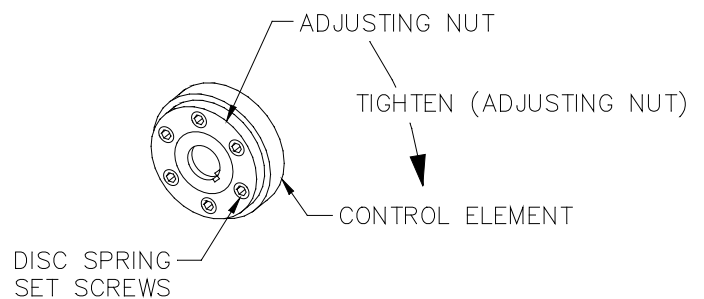

Diagram 2D. Outdoor Clutch Torque Adjustment

CLUTCH TORQUE ADJUSTMENT - CRANES USED OUTDOORS

Back off the disc spring set screws. Turn the adjusting nut clockwise until the disc spring stacks touch the control element. Re-tighten all disc spring set screws until they are flush with the adjusting nut. The proper torque setting is achieved when the drive sprocket will not slip under **normal** operating conditions (**diagram 2D**).

Step 3 - Boom Installation

TIP: Upper and lower formed channels are identical.



STOP! Do not proceed if your support structure does not meet the loading requirements identified in Step 1.4.

- 3.1 Clamp the **lower** wall channel bracket (and spacer plate if required) to the drive mounting plate. Align the wall channel bracket pivot hole with the center of the reducer shaft (**diagram 3A**). Shim (by others) as required. Mark the position of the wall channel (and spacer if required) on the drive mounting plate to aid in re-alignment as it will be removed in a later step.
- 3.2 Determine the position of the **upper** wall channel bracket on the support structure by measuring up from the lower wall channel the required bracket center distance (see the **General Arrangement Drawing** or **chart 1A** for bracket center distance). Clamp the upper wall channel bracket and spacer to the support structure.
- 3.3 Plumb the upper wall channel bracket with the center of the output shaft cover on the top of the reducer. Shim (by others) as needed to ensure the pivot holes on both the upper and lower wall channel brackets are aligned (concentric) with the reducer output shaft.
- 3.4 Bolt the upper wall channel bracket and spacer to support structure. Tighten the mounting bolts (by others; bolts should be grade 5 or better) to manufacturer's specifications.
- 3.5 Bolt the lower pivot assembly to the W-beam web (**diagram 3B**) using the hardware provided. Torque nuts per **chart 3A**.
- 3.6 Bolt the end of beam bracket to the I-beam flange (**diagram 3C**, page 8) using the hardware provided. Torque nuts per **chart 3A**. Bolt a formed clevis to the end of beam bracket. Tighten the nylock nut, but do not torque. Be sure the formed clevis pivots freely.
- 3.7 Assemble the tie rod into the end of beam formed clevis (**diagram 3C**, page 8) using the hardware provided. Torque nuts per **chart 3A**.

Note: Tie rod is right hand thread at each end.

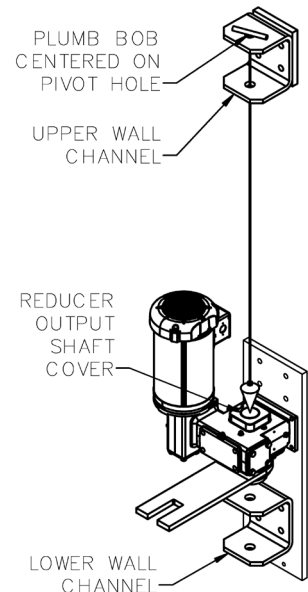

Diagram 3A. Plumbing formed channel brackets.

Bolt Dia.	Torque
1/2"	50 ft.-lbs.
5/8"	95 ft.-lbs.
3/4"	175 ft.-lbs.
7/8"	300 ft.-lbs.
1"	450 ft.-lbs.

Chart 3A. Torque ratings.

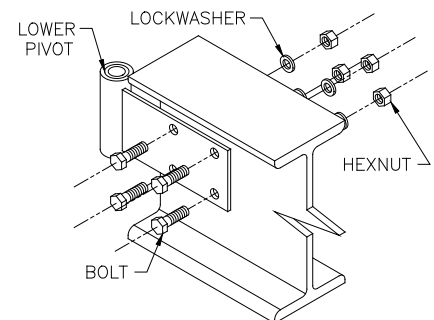

Diagram 3B. Bolting lower pivot assembly to boom.



WARNING: Be sure that the ends of the cotter pins are bent as shown in **diagram 3E**. If cotter pin is cracked or fatigued it must be replaced.

- 3.8 Assemble the remaining formed clevis onto the opposite end of the tie rod (**diagram 3D**) using the hardware provided. Torque nuts per **chart 3A**, page 7. For 1 ton wall channel bracket types, bolt the formed clevis to the upper pivot assembly. Tighten the nylock nut, **but do not torque**. Be sure the formed clevis pivots freely. For 2, 3, and 5 ton wall channel bracket types, install retaining pin and cotter pins (**diagrams 3D** and **3E**).

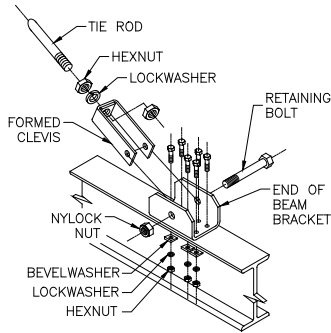

Diagram 3C. Bolting end of beam bracket to boom.

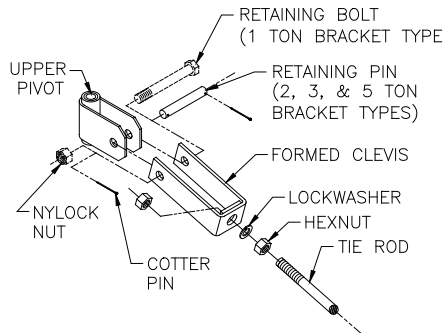

Diagram 3D. Attaching assembly to tie rod.

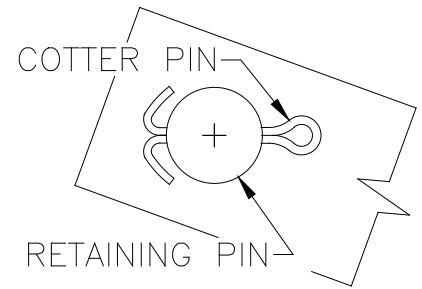

Diagram 3E. Installing cotter pin through retaining pin.

- 3.9 Remove the lower wall channel from the drive mounting plate and bolt to the lower pivot assembly on the jib beam using the hardware provided (**diagram 3F**, page 9). Be sure that the thrust washer is in position. Tighten the pivot bolt nut until the lockwasher is compressed.

TIP: Be sure bronze thrust washers are in place when attaching upper and lower pivots to upper and lower formed channels.

- 3.10 Lift the boom assembly into place. Position the rotation block into the center of the slot in the lever arm. Support the boom assembly at all times until Step 3.13 is complete.
- 3.11 Bolt the lower wall channel (and spacer if required) **through the drive mounting plate to the support structure**, aligning it with the marks from Step 3.1 so the pivot bolt is centered on (concentric with) the reducer output shaft. Tighten all mounting bolts (by others; bolts should be grade 5 or better) to manufacturer's specifications.
- 3.12 Attach the upper pivot assembly to the upper wall channel using the hardware provided (**diagram 3G**, page 9). Be sure that the thrust washer is in position. Tighten the pivot bolt nut until the lockwasher is compressed.



WARNING: Confirm both upper and lower wall channel pivot bolts have not been overtightened causing binding or pinching of the pivots.

3.13 Level the boom to a point of $L/900$ of span above horizontal ($L = \text{span measured in inches}$). For example, the end of the boom on a 10 ft. span would be 0.133" higher than the pivot end ($120"/900 = 0.133"$). Raise the end of the boom by reducing the distance between the clevis assemblies along the tie rod. Once the boom is level, be sure to tighten the nuts on the tie rod to the proper torque (refer to **chart 3A**, page 7 for proper torque rating).

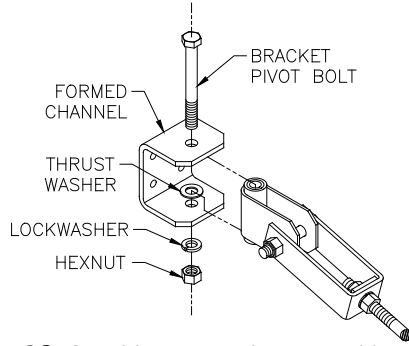

Diagram 3G. Attaching upper pivot assembly to upper formed channel.

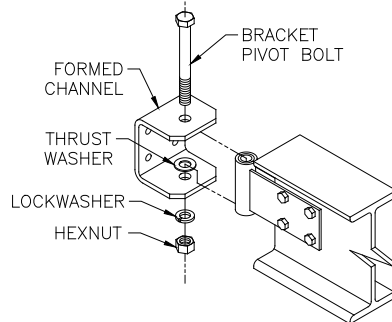

Diagram 3F. Attaching lower pivot assembly to lower formed channel.

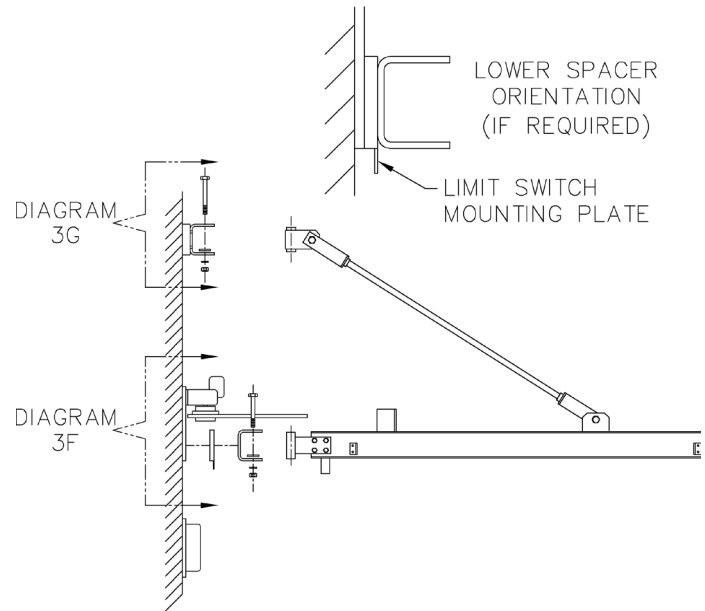

Diagram 3H. Attaching wall bracket jib to formed channels.

Step 4 - Electrification Installation



WARNING: Only qualified personnel that are familiar with following local electrical codes and procedures are permitted to install these motorized cranes. Gorbel is not responsible for the quality of workmanship employed in the installation of motorized crane assemblies.

- 4.1 When ordered with a motorized crane, an electrical control enclosure and junction box will be included (shipped loose).
- 4.2 Enclosure to be mounted on a rigid structure away from all moving components including hoist / hook. Typically it will be mounted on same wall / structure that crane is located on. This allows for easy access and also the option to wire pendant directly from enclosure.
- 4.3 Level enclosure and mount to structure (hardware by others). For hole pattern, reference detail **C-C** on **General Arrangement Drawing** or “Detail C” on **diagram 1C**.
- 4.4 If not already connected, wire limit switches into the top of the junction box (refer to Step 7). Wire festoon cables for the hoist / trolley into the junction box, and add the necessary conduit connections for wiring from the enclosure (conduit connections by others).
- 4.5 Mount junction box to structure near the jib drive assembly, away from all moving components but close enough for the limit switch wires to reach. For hole pattern, reference “Detail D” on **diagram 1C**.
- 4.6 Install power and controls conduit and wiring between the junction box and the enclosure. Interconnection and termination by others (control wiring must be run in separate conduit from the power wiring).
- 4.7 Customer responsible to provide incoming power to match required voltage of motor.
- 4.8 Reference drawing **E-1** for pendant and enclosure schematics.

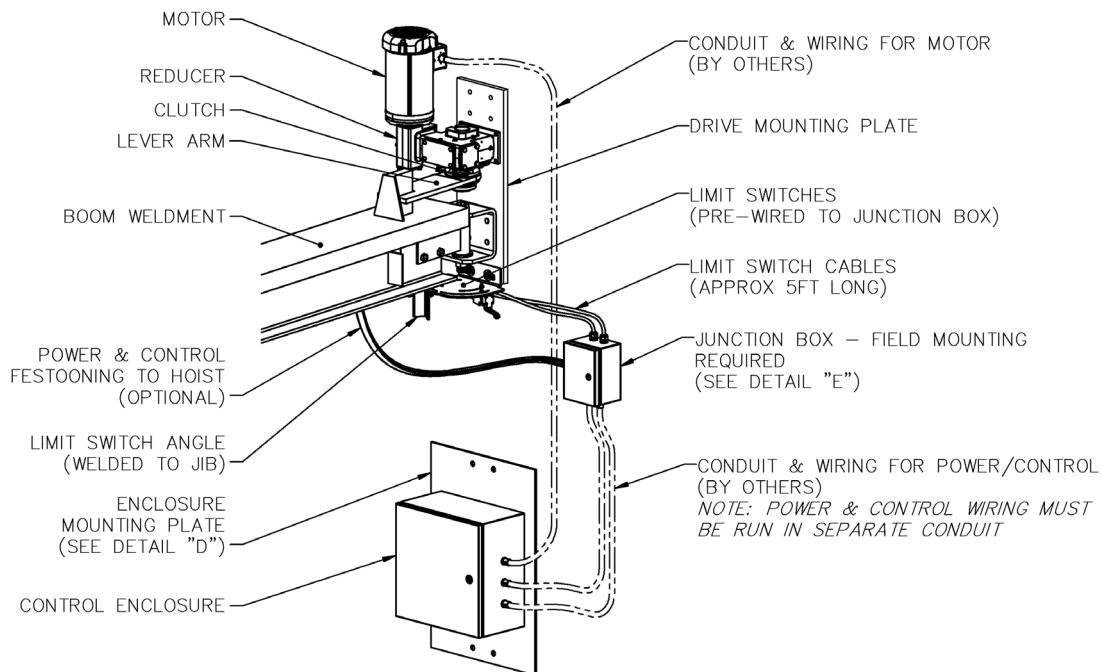

Diagram 4A.

Step 5 - Endstop / Tagline Installation



WARNING: Either endstops or tagline assembly must be installed. (Tagline brackets double as endstops).

5.1 Endstop

- A. Bolt endstop to end of boom closest to pivot (**diagram 5A**).
- B. Roll hoist trolley (by others) into place.
- C. Immediately bolt remaining endstops into place at front of boom (**diagram 5A**).
- D. Torque nuts (refer to **chart 3A**, page 7, for proper torque rating).

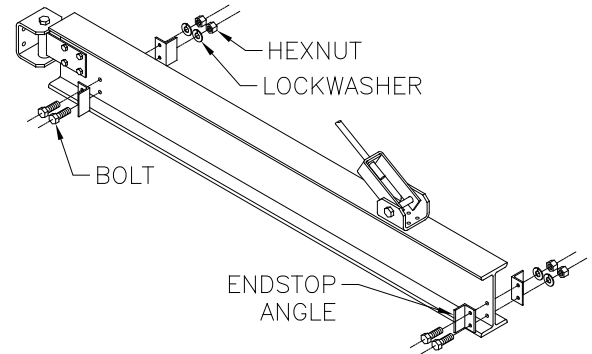

Diagram 5A. Endstop Installation.

5.2 Tagline Assembly

- A. Bolt tagline bracket and endstop angle to end of boom closest to pivot (**diagram 5B**).
- B. Roll hoist trolley (by others) into place.
- C. Immediately bolt remaining tagline bracket and endstop into place at front of boom (**diagram 5B**). Torque nuts (refer to **chart 3A**, page 7, for proper torque rating).
- D. Bolt eyebolts to tagline brackets. Be sure the eyes of the eyebolts are oriented toward each other.
- E. Run wire rope between eyebolts and clamp to form a loop at each end.
- F. Tighten eyebolts so wire rope is taut.
- G. Add "S" hooks to wire rope and squeeze closed the top of the "S" hook.
- H. Space "S" hooks evenly along wire rope and place round power cable/air hose through bottom loop of the "S" hooks.
- I) Squeeze bottom of "S" hooks to grip cable or hose, or tape into place.

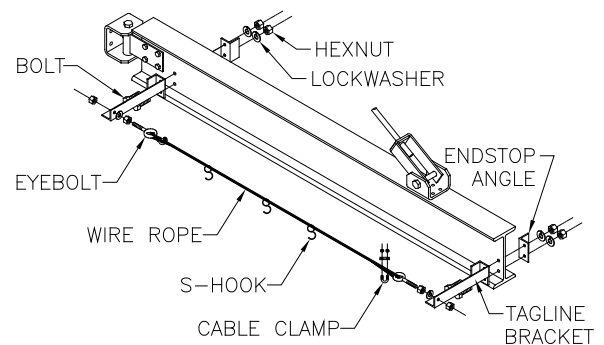

Diagram 5B. Tagline Installation.

Step 6 - ACM

JIB DRIVE CONTROLLER

The drive controller for the jib drive is pre-programmed at Gorbel for single or two speed operation as standard. Three speeds are available upon request through Customer Service. For trouble shooting and general information, a brief summary of how the drive controller is designed to be used is included below. No additional programming is required. All options utilize an adjustable speed controller.



WARNING: The drive controller must only see its own internal voltage and not be connected to an external voltage source. Allowing 24 or 120 control voltage to go through the drive will PERMANENTLY DAMAGE the internal controls!

SINGLE SPEED OPTION

This option utilizes the drive ratio of the reducer and the ratio of the drive to lever arm to produce the standard jib rotation speed. These ratios are determined by the crane parameters (span, capacity, indoor, outdoor, etc.). The drive controller is then programmed for the motor to operate at normal speed (60 Hz).

TWO SPEED OPTION

This option varies the motor speed to determine the desired jib drive speeds. The motor controller is then programmed for the motor to operate at two different percentages of full speed based on the desired speeds specified by the customer at the time the order is placed.

THREE SPEED OPTION

This option is similar to the two speed option listed above. The motor controller is programmed for the motor to operate at three different percentages of full speed based on the desired speeds specified by the customer at the time the order is placed.

TIP: The two or three speed options listed above consist of two or three pre-set speeds, they are not infinitely variable during use.

DRIVE CONTROLLER PROGRAMMING

Gorbel pre-programs a number of parameters in the drive controller prior to shipment. The remaining parameters are left at the factory default settings. All parameters are stored on the EPM module. These parameters are as follows:

Parameter #	Name - SCL/SLM Drive	Name - SCF Drive	New Value - (Setting)
1	Line Voltage	Line Voltage	High or Low (see manual) - (01)
4	Stop Method	Stop Method	Ramp to Stop - (03)
5	Standard Speed Source	Standard Speed Source	Preset Speed - (02)
10	TB-13A Function Select	TB-13A Function Select	Run Reverse - (06)
11	TB-13B Function Select	TB-13B Function Select	Preset Speed - (04)
12	TB-13E Function Select	TB-13C Function Select	Preset Speed - (04)
17	Rotation	Rotation	Forward and Reverse - (02)
19	Acceleration	Acceleration	4 Seconds
20	Deceleration	Deceleration	4 Seconds
23	Minimum Frequency	Minimum Frequency	0 Hz
24	Maximum Frequency	Maximum Frequency	60 Hz
26	Motor Overload	Motor Overload	As Required (see manual)
31	Preset Speed 1	Preset Speed 1	As Required (0-60 Hz)
32	Preset Speed 2	Preset Speed 2	As Required (0-60 Hz)
36	Preset Speed 3	Preset Speed 3	As Required (0-60 Hz)

Preset speeds 2 & 3 are used only if required for two or three speed drives.

Parameter 50 contains the fault history of the last eight (8) faults with the most recent first. Pressing the “Mode” button three times will access this parameter.

Deceleration time: The deceleration time is factory set at 4 seconds. This can be adjusted to a shorter time period with the following warning. If the deceleration time is set to too short a time period, the drive controller will shut down and show an alarm. This is the result of the jib crane having too much inertia for the reducer and motor to stop in such a short time. If this occurs, increase the deceleration time.



WARNING: Do not remove or install the EPM module while power is applied to the drive controller. After removing power from the drive controller, wait three (3) minutes before removing the EPM module for the capacitors to discharge.

Step 7 - Limit Switch Installation



WARNING: Be sure that the power is disconnected prior to working on the limit switches.

The limit switches are designed to shut off the power to the rotation drive motor in a clockwise or counterclockwise direction and are not to serve as a spotting function.

Two limit switches are mounted at the bottom of the jib, below the lower pivot assembly, as shown in **diagram 7A**. Each has an adjustable roller-type lever arm and is actuated by the limit switch angle welded to the bottom of the jib beam. The limit switches must be positioned in the field, by the installer, to shut off power at the desired clockwise and counterclockwise points of rotation. The switches are pre-wired into the wall mounted junction box.

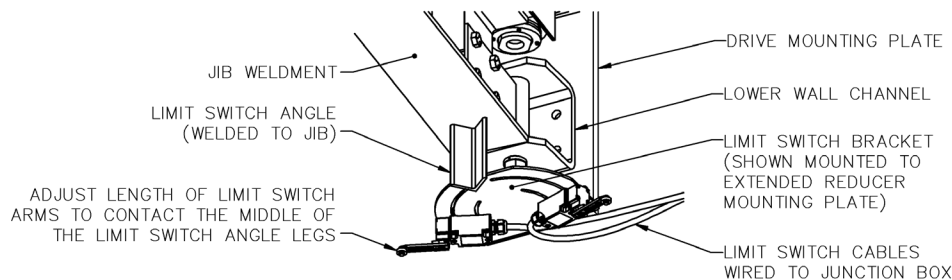

Diagram 7A. Limit Switch Assembly

Installation:

After the jib crane has been erected, the switch set-up is as follows.

- 7.1 Mount the limit switch mounting bracket to either the extended drive mounting plate, or to the mounting plate on the lower wall channel spacer weldment, with the provided 1/2"-13 hardware. Refer to **diagram 7B**.

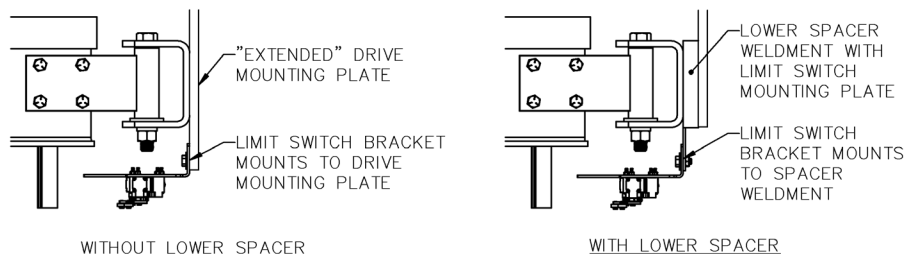

Diagram 7B. Limit Switch Mounting*

7.2 Install the limit switches onto the mounting bracket with the provided #10-32 hardware as shown in **diagram 7C**. For smaller beam sizes, the limit switches may need to be mounted to the top of the limit switch mounting bracket. Leave the hardware loose enough to slide the switches. Loosen the hex socket screw on each adjustable lever arm and extend them so they contact the limit switch angle near the middle of each side. Re-tighten the hex socket screws.

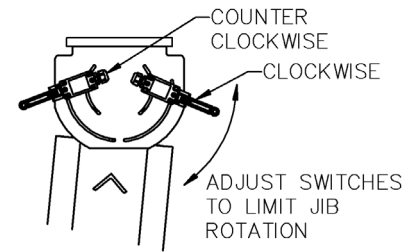

Diagram 7C. Limit Switch Adjustment*

7.3 Place the jib in its clockwise limit position.

7.4 Slide the clockwise limit switch towards the limit switch angle and stop when an audible click is heard from the switch. Tighten the clockwise limit switch mounting hardware.

7.5 Place the jib in the counterclockwise limit position.

7.6 Slide the counterclockwise limit switch towards the limit switch angle and stop when an audible click is heard from the switch. Tighten the counterclockwise limit switch mounting hardware.

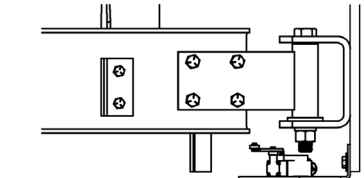

Diagram 7D. Smaller Beams*

*Limit switch cables are not shown for clarity.

Over Travel Adjustment Instructions:

All cranes will experience some over travel after power to the drive is shut off due to inertia of the load acquired during rotation. The amount of over travel is dependent on the application and size of the jib crane. In order to accurately compensate for over travel, it is necessary to test the rotation performance of the jib under full load and determine the actual over travel. Ensure that any possible over travel will not cause the crane to collide with surrounding objects.

7.7 Push the “ON” button to power on the crane controls.

7.8 With the hoist at the end of the boom, lift a capacity load up one half the distance from the floor to the hoist.

7.9 Start rotating the jib crane in the direction of the desired limit. Counterclockwise rotation is used for the diagrams below. It is important to give the jib crane enough starting distance to accelerate to full speed.

7.10 When the crane reaches the desired rotation limit position, the limit switch lever arm will contact the limit switch angle and the power to the drive motor will be shut off. Allow the jib crane to come to a full stop.

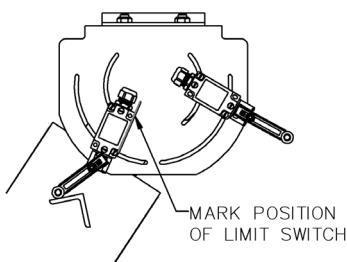

Diagram 7E*

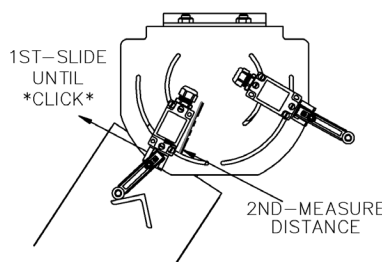

Diagram 7F*

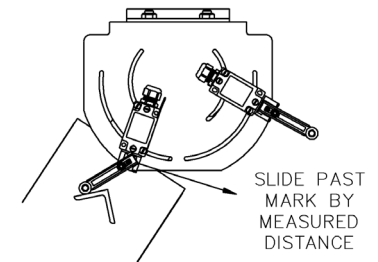

Diagram 7G*

* Limit switch cables are not shown for clarity.

- 7.11 Push the “OFF” button to power down the crane controls.
- 7.12 As shown in **diagram 7E**, mark the position of the activated limit switch on the mounting plate and loosen the limit switch mounting hardware.
- 7.13 Slide the limit switch away from the limit switch angle until the audible “click” is heard. Measure the distance between the switch and the line marking the original position. See **diagram 7F**.
- 7.14 Move the switch past the original mark by the distance measured in step 7.13 and tighten the mounting hardware. See **diagram 7G**. The point is to trip the switch before the actual rotation limit is reached to compensate for any over travel.
- 7.15 Repeat for the limit in the opposite direction.

Step 8 - Accessories (Optional)

Additional Accessories (Consult Gorbel® Representative)

- Flat Wire Conductor Cable
- Flat Wire Cord Grip Connectors
- Wire Rope Trolleys for Flat or Round Cable
- Fusible Disconnect Switch

Step 9 - Final Steps

TIP: Do not throw away this manual: maintenance schedule is on the back cover.

- 9.1 Check to make sure all bolts are tight, nuts are properly torqued and lockwashers are compressed.
- 9.2 Grease all fittings (use Lubriplate #630-AA or equivalent).
- 9.3 If necessary, touch up crane with paint provided.
- 9.4 Keep packing list, Installation Manual and any other inserts filed together in a safe place.

Shut-Down Instructions

Whenever the operator leaves the crane, this procedure should be followed:

1. Raise all hooks to an intermediate position.
2. Spot the crane at an approved designated location.
3. Secure the beam in the shut-down position or storage area. If the crane is an outdoor application and it has a tie down loop, secure tightly especially in high wind areas.
4. Check the crane, hoist and hook storage positions to be sure there is no interference with other pieces of equipment that may be operating in the area.
5. Place all controls in the “**OFF**” position.
6. Open the main switch to the “**OFF**” position.
7. Make a visual check before leaving the crane.

Safety Warnings and Precautions

Safety is very important when operating a jib crane. There are many safety warnings and precautions the operator should be aware of. These include, but are not limited to, the following:

- The jib crane only be used to pick up a **MAXIMUM** of its **RATED CAPACITY**.
- The load will swing when lifted.
- Make sure the power is “**OFF**” prior to doing any electrical work or checking wires and connections.
- When loading, pick load directly up. Crane should not be used to pick up a load diagonally or out of the range of the span.
- Watch for wet spots: oil, water, etc. where the operator may slip.
- Check that all bolts are tight and have lockwashers.
- Make sure endstops are in place, are fully engaging the trolley and the endstop hardware is tight.
- Make sure that festooning cannot be snagged or pinched.
- Check for obstructions in crane travel.
- The operator should have full concentration on the crane and its surroundings at all times.



WARNING: Any changes in ease of movement or unusual noises must be immediately corrected.

Troubleshooting Guide

Problem	Probable Cause	Check & Remedy
Jib crane does not respond to the control station.	<ol style="list-style-type: none"> 1. No power to control panel. 2. Mainline contactor is not activating with "ON" button or staying on. 3. Open control circuits on pendant. 4. No power to drive motor. 5. Clutch slipping. 	<ol style="list-style-type: none"> 1. Check incoming power and fusing. Repair or replace fuse. 2. Open control circuit (repair). Control transformer fusing (replace). 3. Check all termination points in pendant and terminal strip and verify continuity. Repair as required. 4. Check all motor leads. Check for correct voltage at drive motor. Check drive controller for any overloads or errors. (Refer to drive controller manual.) Check drive controller EPM chip is fully seated in controls. 5. Check to see if output shaft of reducer is turning, if so tighten clutch per instructions (see page 6). 6. Call factory and ask for Customer Service if all checks are completed.
Jib rotates in one direction only.	<ol style="list-style-type: none"> 1. Limit switches. 2. Open control circuit. 3. Clutch slippage. 	<ol style="list-style-type: none"> 1. Check switch circuit and confirm switch is not stuck in closed position. 2. Check all termination points in pendant and terminal strip and verify continuity. Repair as required. 3. Check to see if output shaft of reducer is turning, if so tighten clutch per instructions (see page 6). 4. Call factory and ask for Customer Service if all checks are completed.

If you are experiencing any other problems in the start-up or operation of your Gorbel® crane, please call 1-585-924-6262 or 1-800-821-0086 and ask for Customer Service.

Appendix A: Securex Friction Torque Limiter Type C & T Installation & Maintenance Instructions (Size 30 Thru 280)



WARNING: Read and follow all instructions carefully.



WARNING: Disconnect and lock-out power before installation and maintenance. Working on or near energized equipment can result in severe injury or death.



WARNING: Do not operate equipment without guards in place. Exposed equipment can result in severe injury or death.



CAUTION: Periodic inspections should be performed. Failure to perform proper maintenance can result in premature product failure and personal injury.



CAUTION: All electrical work should be performed by qualified personnel and compliant with local and national electrical codes.

GENERAL:

Before assembly, the pressure plates, facings, and center member (sprocket, sheave, plate, etc.) should be free of oil, grease, dirt, and rust. The center member should have a 1.6-micron finish on the area where the friction facings rub to obtain maximum rated capacity and optimum life from the Torque Limiter.

ASSEMBLY:

Refer to the appropriate sketch (see below) and assemble on the torque limiter hub the following: (A) Friction facing, (B) Bushing, (C) Center member (not shown), (D) Friction facing, (E) Pressure plate, (F) Spring(s), (G) Pilot plate (95 to 170 size models only) or (H) Lock washer (30 to 85 size models only), (J) Adjusting nut. When assembling the friction torque limiter type C, please refer to the extra notes below.

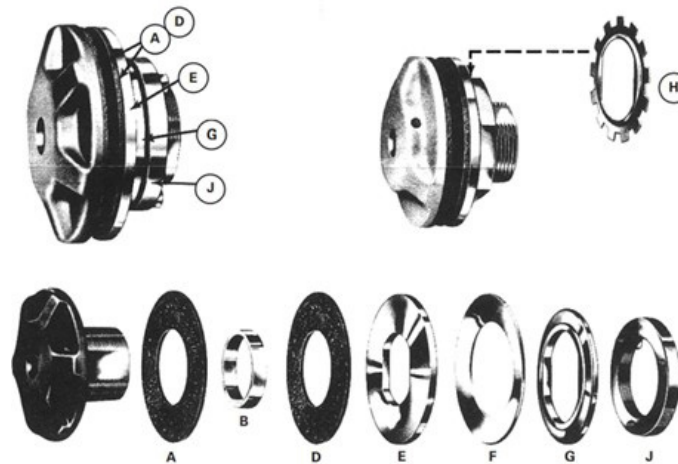

RUNNING-IN:

Torque Limiters should be run-in for the most consistent results. To run-in, adjust the Torque Limiter to 25% of the maximum single spring capacity and slip the center member approximately 50 RPM for approximately 4 minutes.

TORQUE SETTING PROCEDURES:

Type 30 ÷ 85: Loosen the locking screw (A) and tighten the adjusting nut with the proper spanner or hook wrench until a slight contact with the spring is established. Then tighten the adjusting nut further to obtain the pressure necessary to transmit the required torque without slipping. Now check if slip occurs at the required torque value and then tighten the locking screw. After the slip torque preset, the nut is locked in position by means of the appropriate locking washer.

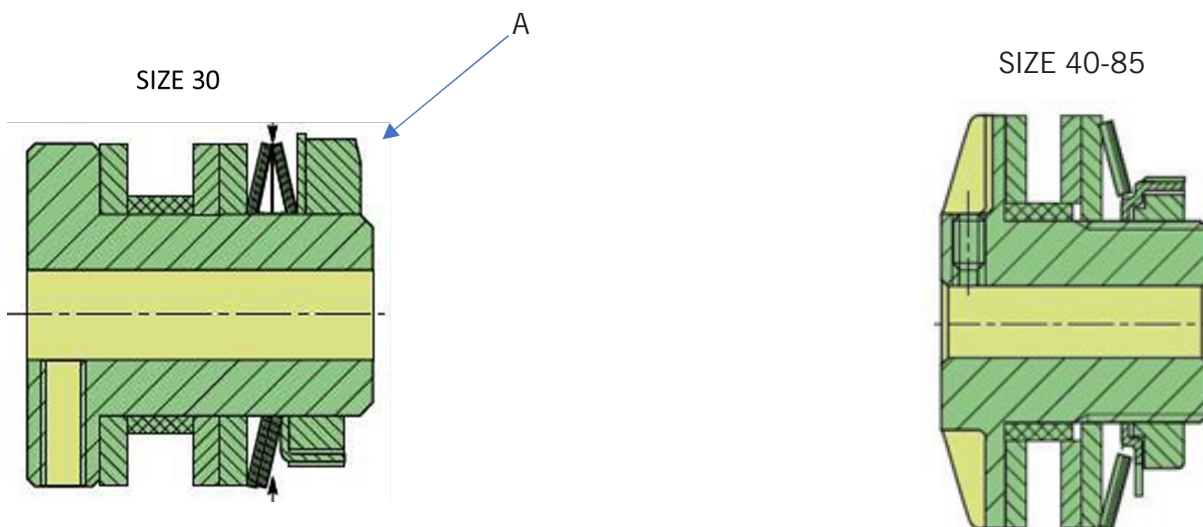

Type 95 ÷ 170: Slip torque is preset by adjustment of 4 or more screws on the nut (B), providing axial load to the disc spring. This system makes the adjustment easy. Apply springs load by loosening the adjusting bolts in approximately 60 degree steps until no slip is observed under maximum load conditions in normal running mode. It is essential that all the bolts have equal adjustments or damage to friction facings will occur. The available diagrams give the approximate slipping torque in function of the number of turns of the adjusting bolts (the fraction refers to the number of faces of the bolts, example: 2/6 means turn 2 out 6 faces present on the bolt).

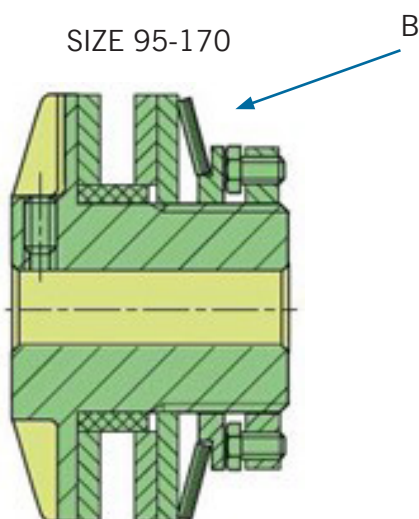

Type 200 and Up: These larger units have a series of smaller disc springs mounted on threaded holding pins which are threaded into the adjusting nut (D). Loosen the spring holding pins (C) and make pre-adjustment of the adjusting nut. Wind the adjusting nut by hand until tight against pilot plate. Ensure friction facings are concentric on the bushing and that the springs are correctly positioned on the pins.

Start tightening spring holding pins until minimal spring resistance is observed. Then, apply springs load by tightening the adjusting bolts in approximately 60 degrees steps until no slip is observed under maximum load conditions in normal running mode. It is essential that all the bolts have equal adjustments or damage to friction facings will occur. The available diagrams give the approximate slipping torque in function of the number of turns of the adjusting bolts (the fraction refers to the number of faces of the bolts, example: 2/6 means turn 2 out 6 faces present on the bolt).

Having set the torque limiter as outlined above, it is common practice to advance the bolts a further 60 degrees to prevent excess on machine start-up. Lock the nut by tightening the two screws located in it.

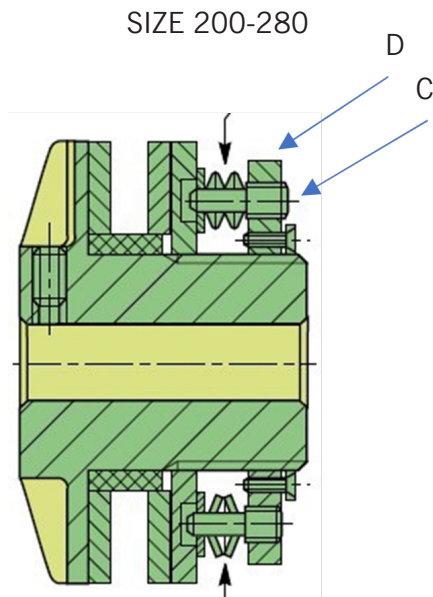

TORQUE CHECKING:

To check the Torque Limiter for the required slip torque, mount the Torque Limiter on a stub shaft and fasten in a bench vise. Wrap the center member (if a sprocket) with a chain and load the chain with weights until the center member rotates. If the center member is a plate, attach a chain or cable to the center member. The breakaway torque will be equal to the radius of the center member in feet times the weight in lbs. on the chain. The breakaway torque should be slightly higher (5% to 10%) than the required slip torque. If the slip torque is too high or too low, readjust torque limiter as per torque setting procedures above. After readjustment, check the breakaway torque in the manner outlined above and repeat adjustments if necessary.

MAINTENANCE:

The Securex series torque limiters do not normally require any maintenance. However, as with all friction torque limiters, regular inspection of the friction surfaces and other related components is highly recommended. The friction pads should be replaced when they have each worn to half of their original, new thickness. At periodic intervals, or if proper torque is not being maintained, inspect Torque Limiter for presence of oil, grease, moisture, or corrosion on the driving surfaces and for proper setting of spring load. Clean and adjust as required. Friction facings and bushings are the only parts that should normally require replacement.

CAUTION:

The operating characteristics and capacity of Torque Limiters are affected by atmospheric conditions, moisture, lubricants, and surface corrosion. To illustrate, the life of the friction facings may be greatly reduced by rust on the center plate. The Torque Limiter ratings are based on average conditions. For best results, the Torque Limiter should be adjusted under conditions like those in which it will be used.

HOW TO REPLACE FRICTION DISCS:

Please refer to the appropriate sketch (see above).

1. Remove the drive chain / belt from the torque limiter center member.
2. Loosen adjusting nut (J).
3. Disassemble all components in the following order: Remove (G) Pilot plate (95 to 170 size models only) or (H) Lock washer (30 to 85 size models only), (F) Spring(s), (E) Pressure plate, (D) Friction facing, (C) Center member (not shown), (B) Bushing and (A) Friction facing.
4. Reassemble by placing new friction discs on both sides of a new sprocket and a new sintered bushing. Please refer to the assembly instructions above.



EXTRA NOTES FOR TYPE C ASSEMBLING PROCEDURES:

When assembling type C friction torque limiter, make sure that misalignments are within the allowed values indicated below:

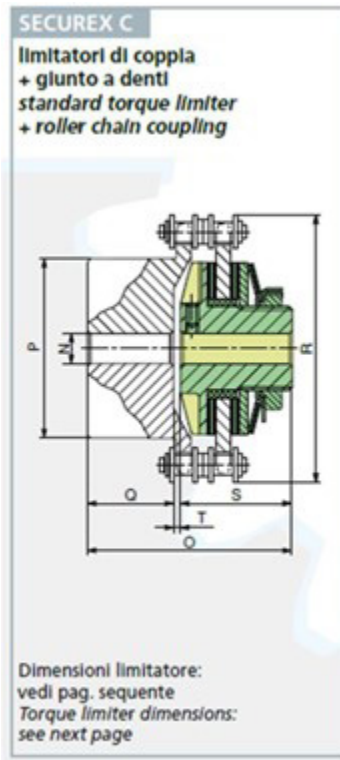

Tipo Type	Max. Coppia Max. torque (Nm)	Nr. Molle Springs	Max. disallineamento Max. misalignment		N Alesaggio giunto Coupling bore		O	P	Q	R	S	T	Ingranaggio per catena Chain sprockle		
			Parallelo Parallel	Angolare Angular	Min.	Max.							N. denti Nr. teeth	Passo Pitch	
C 5/30	5	2			11	22	55	37	22,5	57,1	31	1,5	16	3/8	
C 10/30	10	2	0,20	30'	8	40	55	55	25	75,2	28	2	22	3/8	
C 15/40	15	1													
C 28/40	28	2	0,20	30'	8	40	55	55	25	75,2	28	2	22	3/8	
C 40/40	40	3													
C 30/45	30	1													
C 55/45	55	2	0,25	30'	8	40	59,5	55	25	75,2	33	1,5	22	3/8	
C 70/45	70	3													
C 70/65	70	1													
C 120/65	120	2	0,25	30'	15	48	85	70	32	106,2	50	3	18	5/8	
C 130/85	130	1													
C 240/85	240	2	0,35	30'	15	60	100	90	42	138	55	3	20	3/4	
C 190/95	190	1													
C 340/95	340	2	0,35	30'	15	60	110	90	42	138	66	3	20	3/4	
C 350/120	350	1													
C 650/120	650	2	0,40	30'	20	80	130	120	50	183,5	77	3	20	1"	
C 650/140	650	1													
C 1200/140	1200	2	0,50	30'	25	100	149	130	60	199,5	86	3	22	1"	
C 1000/170	1000	1													
C 1800/170	1800	2	0,50	30'	30	100	170	158	74	231,6	93	3	26	1"	
C 2200/200	2200	24													
C 4000/200	4000	24	0,50	30'	35	100	194	150	85	264	105	3	30	1"	
C 3800/254	3800	32													
C 6800/254	6800	32	0,80	30'	50	150	255	230	130	390,7	120	5	36	1 1/4	
C 5500/280	5500	32													
C 10000/280	10000	32	0,80	30'	50	150	255	230	130	390,7	120	5	36	1 1/4	

Crane Operator Instructions

TIP: Be sure your installers, maintenance personnel, and operators realize this jib can only be used to pick up a **maximum** of its **rated capacity**.

Overhead cranes and jib cranes generally handle materials over working areas where there are personnel. Therefore, it is important for the Crane Operator to be instructed in the use of the crane and to understand the severe consequences of careless operation.

It is not intended that these suggestions take precedence over existing plant safety rules and regulations or OSHA regulations. However, a thorough study of the following information should provide a better understanding of safe operation and afford a greater margin of safety for people and machinery on the plant floor. It must be recognized that these are suggestions for the Crane Operator's use. It is the responsibility of the owner to make personnel aware of all federal, state, and local rules and codes, and to make certain operators are properly trained.

Qualifications

Crane operation, to be safe and efficient, requires skill: the exercise of extreme care and good judgment, alertness and concentration, and rigid adherence to proven safety rules and practices as outlined in applicable and current ANSI and OSHA safety standards. In general practice, no person should be permitted to operate a crane:

- Who cannot speak the appropriate language or read and understand the printed instructions.
- Who is not of legal age to operate this type of equipment.
- Whose hearing or eyesight is impaired (unless suitably corrected with good depth perception).
- Who may be suffering from heart or other ailments which might interfere with the operator's safe performance.
- Unless the operator has carefully read and studied this operation manual.
- Unless the operator has been properly instructed.
- Unless the operator has demonstrated his instructions through practical operation.
- Unless the operator is familiar with hitching equipment and safe hitching equipment practices.

Handling the Jib Boom Motion

Before using the boom of the jib crane, the operator should be sure the hook is high enough to clear any obstruction. Before a load is handled by the crane, the jib boom should be brought into position so that it is directly over the load. Start the jib boom slowly and bring it up to speed gradually. Approaching the place where it is desired to stop the jib, reduce the boom speed.

Handling the Trolley Motion

Before a load is handled, the hoist should be positioned directly over the load that is to be handled. When the slack is taken out of the slings, if the hoist is not directly over the load, bring it directly over the load before hoisting is continued. Failure to center the hoist over the load may cause the load to swing upon lifting. Always start the trolley motion slowly and reduce the trolley speed gradually.

Handling the Hoist Motion

Refer to the lifting (hoist) equipment's operating instructions.

General Suggestions

Know Your Crane

Crane operators should be familiar with the principal parts of a crane and have a thorough knowledge of crane control functions and movements. The crane operator should be required to know the location and proper operation of the main conductor disconnecting means for all power to the attachments on the crane.

Responsibility

Each crane operator should be held directly responsible for the safe operation of the crane. Whenever there is any doubt as to SAFETY, the crane operator should stop the crane and refuse to handle loads until: (1) safety has been assured or (2) the operator has been ordered to proceed by the supervisor, who then assumes all responsibility for the SAFETY of the lift.

Do not permit **ANYONE** to ride on the hook or a load.

Inspection

Test the crane movement and any attachments on the crane at the beginning of each shift. Whenever the operator finds anything wrong or apparently wrong, the problem should be reported immediately to the proper supervisor and appropriate corrective action taken.

Operating Suggestions

One measure of a good crane operator is the smoothness of the crane operation. The good crane operator should **know** and follow these proven suggestions for safe, efficient crane handling.

1. The crane should be moved smoothly and gradually to avoid abrupt, jerky movements of the load. Slack must be removed from the sling and hoisting ropes before the load is lifted.
2. Center the crane over the load before starting the hoist to avoid swinging the load as the lift is started. Loads should not be swung by the crane to reach areas not under the crane.
3. Crane-hoisting ropes should be kept vertical. Cranes shall not be used for side pulls.
4. Be sure everyone in the immediate area is clear of the load and aware that a load is being moved.
5. Do not make lifts beyond the rated load capacity of the crane, sling chains, rope slings, etc.
6. Make certain that before moving the load, load slings, load chains, or other lifting devices are fully seated in the saddle of the hook with hook latch closed (if equipped with hook latch).
7. Check to be sure that the load and/or bottom block is lifted high enough to clear all obstructions when moving boom or trolley.
8. At no time should a load be left suspended from the crane unless the operator has the push button with the power on, and under this condition keep the load as close as possible to the floor to minimize the possibility of an injury if the load should drop. When the crane is holding a load, the crane operator should remain at the push button.
9. Do not lift loads with sling hooks hanging loose. If all sling hooks are not needed, they should be properly stored, or use a different sling.
10. All slings or cables should be removed from the crane hooks when not in use (dangling cables or hooks hung in sling rings can inadvertently snag other objects when the crane is moving).
11. Operators shall not carry loads and/or empty bottom blocks over personnel. Particular additional caution should be practiced when using magnet or vacuum devices. Loads, or parts of loads, held magnetically could drop. Failure to power magnets or vacuum devices can result in dropping the load. Extra precaution should be exercised when handling molten metal in the proximity of personnel.
12. Whenever the operator leaves the crane the following procedure should be followed:
 - Raise all hooks to an intermediate position.
 - Spot the crane at an approved designated location.
 - Place all controls in the "off" position.
 - Open the main switch to the "off" position.
 - Make visual check before leaving the crane.
13. In case of emergency or during inspection, repairing, cleaning or lubrication, a warning sign or signal should be displayed and the main switch should be locked in the "off" position. This should be done whether the work is being done by the crane operator or by others.
14. Contact with rotation stops or trolley end stops shall be made with extreme caution. The operator should do so with particular care for the safety of persons below the crane, and only after making certain that any persons on other cranes are aware of what is being done.
15. ANY SAFETY FEATURES AND MECHANISMS BUILT-IN OR OTHERWISE PROVIDED WITH THE CRANE BY GORBEL ARE REQUIRED FOR THE SAFE OPERATION OF THE CRANE. DO NOT, UNDER ANY CIRCUMSTANCES, REMOVE OR OTHERWISE IMPAIR OR DISABLE THE PROPER FUNCTIONING OF ANY CRANE SAFETY MECHANISMS OR FEATURES BUILT-IN OR OTHERWISE PROVIDED BY GORBEL FOR SAFE OPERATION OF THE CRANE. ANY REMOVAL, IMPAIRMENT OR DISABLING OF ANY SUCH SAFETY MECHANISMS OR FEATURES OR OTHER USE OR OPERATION OF THE CRANE WITHOUT THE COMPLETE AND PROPER FUNCTIONING OF ANY SUCH SAFETY MECHANISMS OR FEATURES AUTOMATICALLY AND IMMEDIATELY VOIDS ANY AND ALL EXPRESS AND IMPLIED WARRANTIES OF ANY KIND OR NATURE.

Limited Warranty

It is agreed that the equipment purchased hereunder is subject to the following LIMITED warranty and no other. Gorbel Incorporated ("Gorbel") warrants the manual push-pull Work Station Cranes, Jib Crane, and Gantry Crane products to be free from defects in material or workmanship for a period of ten years or 20,000 hours use from date of shipment. Gorbel warrants the Motorized Work Station Cranes and Jib Crane products to be free from defects in material or workmanship for a period of two years or 4,000 hours use from the date of shipment. This warranty does not cover Gantry Crane wheels. This warranty shall not cover failure or defective operation caused by operation in excess of recommended capacities, misuses, negligence or accident, and alteration or repair not authorized by Gorbel. No system shall be field modified after manufacture without the written authorization of Gorbel, Inc. Any field modification made to the system without the written authorization of Gorbel, Inc. shall void Gorbel's warranty obligation. OTHER THAN AS SET FORTH HEREIN, NO OTHER EXPRESS WARRANTIES, AND NO IMPLIED WARRANTIES, ORAL OR WRITTEN, INCLUDING BUT NOT LIMITED TO THE WARRANTIES OF MERCHANTABILITY OR FITNESS FOR PARTICULAR PURPOSE, ARE MADE BY GORBEL WITH RESPECT TO ITS PRODUCTS AND ALL SUCH WARRANTIES ARE HEREBY SPECIFICALLY DISCLAIMED. GORBEL SHALL NOT BE LIABLE UNDER ANY CIRCUMSTANCES FOR ANY INCIDENTAL, SPECIAL AND/OR CONSEQUENTIAL DAMAGES WHATSOEVER, WHETHER OR NOT FORESEEABLE, INCLUDING BUT NOT LIMITED TO DAMAGES FOR LOST PROFITS AND ALL SUCH INCIDENTAL, SPECIAL AND/OR CONSEQUENTIAL DAMAGES ARE HEREBY ALSO SPECIFICALLY DISCLAIMED. Gorbel's obligation and Purchaser's or end user's sole remedy under this warranty is limited to the replacement or repair of Gorbel's products at the factory, or at the discretion of Gorbel, at a location designated by Gorbel. Purchaser or end user shall be solely responsible for all freight and transportation costs incurred in connection with any warranty work provided by Gorbel hereunder. Gorbel will not be liable for any loss, injury or damage to persons or property, nor for damages of any kind resulting from failure or defective operation of any materials or equipment furnished hereunder. Components and accessories not manufactured by Gorbel are not included in this warranty. Purchaser's or end user's remedy for components and accessories not manufactured by Gorbel is limited to and determined by the terms and conditions of the warranty provided by the respective manufacturers of such components and accessories.

A) DISCLAIMER OF IMPLIED WARRANTY OF MERCHANTABILITY

Gorbel and Purchaser agree that any claim made by Purchaser which is inconsistent with Gorbel's obligations and the warranty remedies provided with Gorbel's products, and in particular, special, incidental and consequential damages, are expressly excluded.

B) DISCLAIMER OF IMPLIED WARRANTY OF FITNESS FOR PARTICULAR PURPOSE

Gorbel and Purchaser agree that the implied warranty of fitness for particular purpose is excluded from this transaction and shall not apply to the goods involved in this transaction.

C) DISCLAIMER OF EXPRESS WARRANTY

Gorbel's agents, or dealer's agents, or distributor's agents may have made oral statements about the machinery and equipment described in this transaction. Such statements do not constitute warranties, and Purchaser agrees not to rely on such statements. Purchaser also agrees that such statements are not part of this transaction.

D) DISCLAIMER OF SPECIAL, INCIDENTAL AND CONSEQUENTIAL DAMAGES

Gorbel and Purchaser agree that any claim made by Purchaser which is inconsistent with Gorbel's obligations and the warranty remedies provided with Gorbel's products, and in particular, special, incidental and consequential damages, are expressly excluded.

E) DEALER OR DISTRIBUTOR NOT AN AGENT

Gorbel and Purchaser agree that Purchaser has been put on notice that dealer or distributor is not Gorbel's agent in any respect for any reason. Gorbel and Purchaser also agree that Purchaser has been put on notice that dealer or distributor is not authorized to incur any obligations or to make any representations or warranties on Gorbel's behalf other than those specifically set forth in Gorbel's warranty provided in connection with its product.

F) MERGER

This warranty agreement constitutes a final and complete written expression of all the terms and conditions of this warranty and is a complete and exclusive statement of these terms.

G) PAINTING

Every crane (excluding components) receives a quality paint job before leaving the factory. Unfortunately, no paint will protect against the abuses received during the transportation process via common carrier. We have included at least one (1) twelve ounce spray can for touchup with each crane ordered (unless special paint was specified). If additional paint is required, contact a Gorbel Customer Service Representative at 1-800-821-0086 or 1-585-924-6262.

Title and Ownership:

Title to the machinery and equipment described in the foregoing proposal shall remain with Gorbel and shall not pass to the Purchaser until the full amount herein agreed to be paid has been fully paid in cash.

Claims and Damages:

Unless expressly stated in writing, goods and equipment shall be at Purchaser's risk on and after Seller's delivery in good shipping order to the Carrier. Gorbel shall in no event be held responsible for materials furnished or work performed by any person other than it or its authorized representative or agent.

Cancellations:

If it becomes necessary for the purchaser to cancel this order wholly or in part, he shall at once so advise Gorbel in writing. Upon receipt of such written notice all work will stop immediately. If the order entails only stock items, a flat restocking charge of 15% of the purchase price will become due and payable by the Purchaser to Gorbel. Items purchased specifically for the canceled order shall be charged for in accordance with the cancellation charges of our supplier plus 15% for handling in our factory. The cost of material and/or labor expended in general fabrication for the order shall be charged for on the basis of total costs to Gorbel up to the time of cancellation plus 15%.

Returns:

No equipment, materials or parts may be returned to Gorbel without express permission in writing to do so.

Extra Charge Delay: If Purchaser delays or interrupts progress of Seller's performance, or causes changes to be made, Purchaser agrees to reimburse Gorbel for expense, if any, incident to such delay.

Changes and Alterations:

Gorbel reserves the right to make changes in the details of construction of the equipment, as in its judgment, will be in the interest of the Purchaser; will make any changes in or additions to the equipment which may be agreed upon in writing by the Purchaser; and Gorbel is not obligated to make such changes in products previously sold any customer.

Third Party Action:

Should Gorbel have to resort to third party action to collect any amount due after thirty (30) days from date of invoice, the Purchaser agrees to pay collection costs, reasonable attorney's fees, court costs and legal interest.

OSHA Responsibilities:

Gorbel agrees to full cooperate with Purchaser in the design, manufacture or procurement of safety features or devices that comply with OSHA regulations. In the event additional equipment or labor shall be furnished by Gorbel, it will be at prices and standard rates then in effect, or as may be mutually agreed upon at the time of the additional installation.

Equal Employment Opportunity:

Gorbel agrees to take affirmative action to ensure equal employment opportunity for all job applicants and employees without regard to race, color, age, religion, sex, national origin, handicap, veteran, or marital status. Gorbel agrees to maintain non-segregated work facilities and comply with rules and regulations of the Secretary of Labor or as otherwise provided by law or Executive Order.

Maintenance Schedule

Maintenance		Frequency*
Lubrication	See Lubrication Schedule below	
Adjustments	<p><u>Check:</u></p> <ul style="list-style-type: none"> • Endstops are in place and are fully engaging the trolley • Level of boom • Electrification system (be sure the power is OFF which checking wires & connections) • All hardware is in place and tight (refer to chart 3A, page 7, for proper torque rating) <p><u>Check:</u></p> <ul style="list-style-type: none"> • Level of boom • Electrification system (be sure the power is OFF when checking wires & connections) • Endstop or Tagline Assemblies. Make sure lockwashers are compressed and nuts are tightened to torque specifications (refer to chart 3A, page 7, for proper torque rating) • Mounting Bolts. Make sure lockwashers are compressed and nuts are tightened to manufacturer's specifications. • Tighten all hardware (refer to chart 3A, page 7, for proper torque rating) 	<p>After lifting the first few loads</p> <p>500 hours or 3 months</p>
Inspection	<p><u>Check:</u></p> <ul style="list-style-type: none"> • Upper Pivot Assembly. Make sure that lockwashers are compressed and nylock nut is tight. Check for wear on thrust washer. • Lower Pivot Assembly. Make sure that lockwashers are compressed. Check for wear on thrust washer. Check that nuts on bolts through I-beam web are tightened to torque specifications (refer to chart 3A, page 7, for proper torque rating) • End of Beam Bracket. Check that lockwashers are compressed. Check that nuts on bolts through I-beam flange are tightened to torque specifications (refer to chart 3A, page 7, for proper torque rating) • Accessory Items. Conduct a general inspection • Gorbels® Crane. Conduct a visual inspection of entire crane 	1000 hours or 6 months

* Federal, state and local codes may require inspection and maintenance checks more often. Please check the state and local code manuals in your area.

Lubrication Schedule

Component	Lubricant	Frequency*
Pivot Assemblies (Upper and Lower)	Hi-pressure bearing grease Lubriplate #630-AA Multi-purpose grease	Every 1000 hours or 6 months
Worm Gear Reducer	<p>AGMA Standard #8 compound</p> <p><u>Different manufacturers:</u></p> <ul style="list-style-type: none"> • City Service Co. CITGO Oil #680-7 • Chevron - NL Gear Comp. #680 • Sun Oil Corp. - SUNEP #1150 • Texaco Inc. - Honor Cyl. Oil #680 • Gulf Oil Corp. - Transgear #EP680 • Shell Oil Corp. - Omala #680 • Friske Brothers Refining - CP Gear Oil #8 • Keystone Division - #K-600 • Mobil Oil Corp. - Mobil #600W Super • American Lube Inc. - AGMA #8 	<p>1st Lube: After 250 hours of operation</p> <p>Regularly: 500 hours or 3 months</p>

Above is the suggested schedule. Be sure to always use high grade lubricants. For hoist and trolley maintenance, consult manufacturer's maintenance instructions and lubrication schedule.

*Federal, state and local codes may require inspection and maintenance checks more often. Please check the state and local code manuals in your area.



WARNING: Any changes in rolling effort, rotation effort or unusual noises must be immediately identified and corrected.