

G-Force[®] & Easy Arm Q2 and iQ2 Series All Models/All Capacities

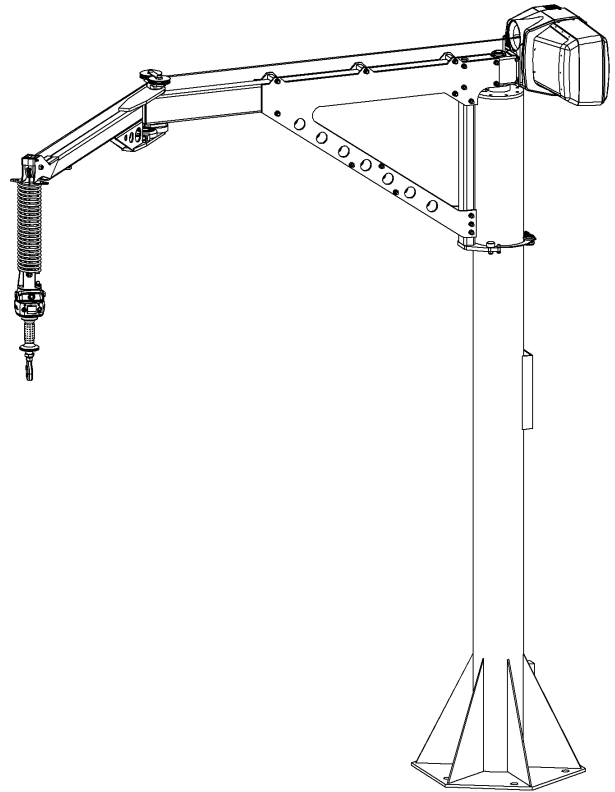
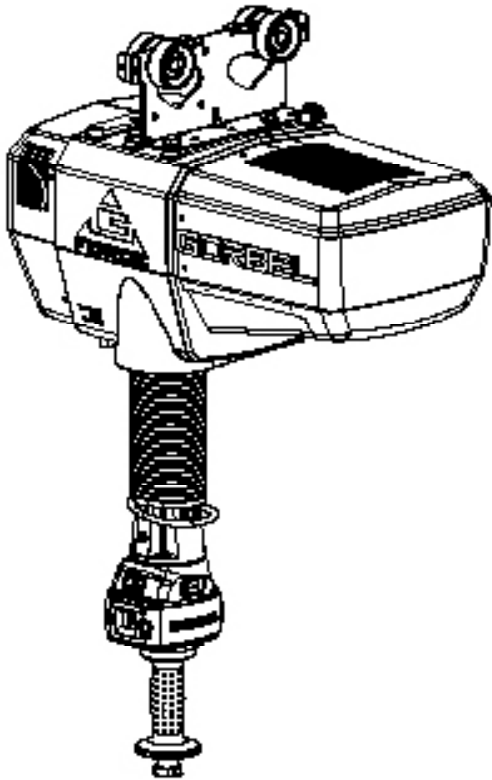

PLEASE NOTE:

This is the Service Manual for Gorbel's G-Force and Easy Arm Q2 & iQ2 units.

- If you need Installation instructions for you Q2 or iQ2 G-unit, you can find the latest Installation & Maintenance manuals under the *Service & Support* tab on www.gorbel.com
- If you need a Service manual for your Q or iQ model, please contact Gorbel's After the Sales Service department at (800) 821-0086

Gorbel[®] Customer Order No. / Serial No. _____

Gorbel[®] Dealer _____

This page intentionally left blank.

Index

| | Page |
|--|-------------|
| Chapter 1 - Safe Hoist Operating Guidelines | 1-1 |
| Chapter 2 - Technical Specifications | 2-1 |
| Chapter 3 - Removal Procedure..... | 3-1 |
| Chapter 4 - Control and Programming | 4-1 |
| Chapter 5 - Software Field Upgrade..... | 5-1 |
| Chapter 6 - Troubleshooting | |
| • Troubleshooting Procedure | 6-1 |
| • Troubleshooting Section I: Functional Failure Table | 6-2 |
| • LED Chart..... | 6-6 |
| • Troubleshooting Section II: System Fault Diagnostics Chart | 6-7 |
| • Q2-iQ2 Fault/Error/Warning Code Corrective Actions..... | 6-9 |
| Chapter 7 - Electrical Schematics | 7-1 |
| Chapter 8 - Adjustments | |
| • Limit Switch Adjustment | 8-1 |
| • Wire Rope Replacement Adjustment | 8-2 |
| • Linear Transducer Adjustment | 8-3 |
| • Slack Spring Adjustment | 8-4 |
| Chapter 9 - Parts and Assembly | |
| • Actuator | 9-2 |
| • Sliding Handle | 9-30 |
| • Pendant Handle..... | 9-38 |
| • Force Sensing Handle | 9-47 |
| • Coil Cords..... | 9-51 |
| • G360™ | 9-55 |
| • Easy Arm Components..... | 9-61 |
| Chapter 10 - Recommended Tools & Parts..... | 10-1 |

This page intentionally left blank.

Chapter 1 - Safe Hoist Operating Guidelines

General

There is no one single factor that is more important for minimizing the possibility of personal injury to the operator and those working in the area, or damage to property, equipment, or material than being familiar with the equipment and using Safe Operating Practices.

Hoists/trolleys are designed for lifting and transporting of material only. Under no circumstances, either during initial installation or in any other use, should the hoist be used for lifting or transporting personnel.

No operator should be permitted to use the equipment that is not familiar with its operation, is not physically or mentally fit, or has not been schooled in safe operating practices. The misuse of hoists can lead to certain hazards which cannot be protected against by mechanical means; hazards which can only be avoided by the exercise of intelligence, care, and common sense.

Safe Operating Practices also involve a program of periodic inspection and preventative maintenance (covered in a separate section). Part of the operator's training should be an awareness of potential malfunctions/hazards requiring adjustments or repairs, and bringing these to the attention of supervision for corrective action.

Supervision and management also have an important role to play in any safety program by ensuring that a maintenance schedule is adhered to, and that the equipment provided for the operators is suitable for the job intended without violation of one or more of the rules covering safe operating practices and good common sense.

The Safe Operating Practices shown are taken in part from the following publications:

- American National Standard Institute (ANSI)
- Safety Standards for Cranes, Derricks, Hoists
- ANSI B30.2 - Overhead and Gantry Cranes
- ANSI B30.16 - Overhead Hoists

Do's and Don'ts (Safe Operation of Hoists)

The following are Do's and Don'ts for safe operation of overhead hoists. A few minutes spent reading these rules can make an operator aware of dangerous practices to avoid and precautions to take for his own safety and the safety of others. Frequent examinations and periodic inspections of the equipment as well as a conscientious observance of safety rules may save lives as well as time and money.

DON'TS - HOISTS

1. Never lift or transport a load until all personnel are clear and do not transport the load over personnel.
2. Do not allow any unqualified personnel to operate hoist.
3. Never pick up a load beyond the capacity rating appearing on the hoist. Overloading can be caused by jerking as well as by static overload.
4. Never carry personnel on the hook or the load.
5. Do not operate hoist if you are not physically fit.
6. Do not operate hoist to extreme limits of travel of cable without first checking for proper limit switch action.
7. Avoid impact between two hoists or between hoist and end stop.

8. Do not tamper with or adjust any parts of the hoist unless specifically authorized to do so.
9. Never use the load cable as a sling.
10. Do not divert attention from load while operating hoist.
11. Never leave a suspended load unattended.
12. Do not use limit switch(es) for normal operating stop(s). These are safety devices only and should be checked on a regular basis for proper operation.
13. Never operate a hoist that has an inherent or suspected mechanical or electrical defect.
14. Do not use load cable as a ground for welding. Never touch a live welding electrode to the load cable.
15. Do not jog controls unnecessarily. Hoist motors are generally high torque, high slip types. Each start causes an inrush of current greater than the running current and leads to overheating and current failure, or burnout, if continued to excess.
16. Do not operate hoist if load is not centered under hoist.
17. Do not operate hoist if cable is twisted, kinked, or damaged.
18. Do not remove or obscure label.
19. Do not permanently activate operator present sensor.
20. Do not dis/reassemble components while the hoist is energized, 'Hot-Swapping' of components is strongly discouraged.

DO'S - HOISTS

1. Read and follow manufacturer's instruction, installation, and maintenance manuals. When repairing or maintaining a hoist, use only manufacturer's recommended parts and materials.
2. Read and follow all instruction and warning information on or attached to a hoist.
3. Remove the hoist from service and thoroughly inspect and repair, as necessary, if unusual performance or visual defects (such as peculiar noise, jerky operations, travel in improper direction, or obviously damaged parts) are noticed.
4. Establish a regular schedule of inspection and maintain records for all hoists with special attention given to hooks, load cables, brakes, and limit switches.
5. Check operation of brakes for excessive drift.
6. Never lift loads over people, etc.
7. Check for damaged hooks and load cable.
8. Keep load cable clean and well maintained.
9. Check the load cable for improper seating, twisting, kinking, wear, or other defects before operating the hoist.
10. Make sure a load clears neighboring stockpiles, machinery, or other obstructions when raising, lowering, or traveling the load.
11. Center hoist over the load before operating.
12. Avoid swinging of load or load hook when traveling the hoist.
13. Be sure the load attachment is properly seated in the saddle of the hook. Balance load properly before handling. Avoid hook tip loading.
14. Pull in a straight line, so that neither hoist body nor load cable are angled around an object.
15. Take up slack slowly.
16. Know the hand signals for hoisting, cross travel, and crane travel if working with cab-operated hoists or cranes. Operators should accept signals of only those persons authorized to give them.

Chapter 2 - Technical Specifications: G-Force Q2/iQ2

| G-Force Q2 & iQ2 | | | | | |
|--|-------------------|--|---------------------------|---|---|
| Max Capacity | lb. [kg] | 165 lb [75kg] | 330 lb [150kg] | 660 lb [300kg] | 1320 lb [600kg] |
| Max Lift Speed Unloaded | ft/min [m/min] | 195 fpm [29 mpm] | 95 fpm [29 mpm] | 45 fpm [14 mpm] | 25 fpm [8 mpm] |
| Max Lift Speed Fully Loaded | ft/min [m/min] | 120 fpm [37 mpm] | 60 fpm [18 mpm] | 40 fpm [12 mpm] | 20 fpm [6 mpm] |
| Max Float Mode Lift Speed | ft/min [m/min] | 110 fpm [34 mpm] | 55 fpm [17 mpm] | 40 fpm [12 mpm] | 20 fpm [6 mpm] |
| Max Lift Range | ft [m] | 11 [3.4] | | | 5.5 [1.7] |
| Max Lift Stroke | ft [m] | 8 [2.4] | | | 5.5 [1.7] |
| Primary Voltage | VAC | Single Phase 220 +/- 10% | | | |
| Maximum Current | Amps | 6 | | | |
| Duty Cycle | | H5 | H5 | H4 | H3 |
| Available Tooling Power | | 24VDC @ 0.5A | | | |
| Lifting Media | | 3/16" dia. 19x7 Preformed Stainless Steel Wire Rope | | 1/4" dia. 19x7 Preformed Stainless Steel Wire Rope | 1/4" dia. 7x19 Preformed Stainless Steel Wire Rope |
| Operating Temperature Range | °F [°C] | 41 – 122 [5 – 50] | | | |
| Operating Humidity Range (Non-Condensing) | | 35 - 90% | | | |
| Environmental Rating | | NEMA 5 | | | |
| Weight Display Accuracy | | +/- 1% Rated Capacity | | | |
| UL/CSA Certified | | YES | | | |
| CE Certified | | YES | | | |
| Actuator I/O (iQ2 Model) | | | | | |
| Inputs, Type | | 8, Sinking | | | |
| Input Current @ 24 VDC | | 6ma | | | |
| Outputs, Type | | 4, FET | | | |
| Continuous Current/Channel | Amps | 0.5 | | | |
| Module Max Current | Amps | 0.5 | | | |
| Handle with X67 I/O Module (iQ2 Model) | | | | | |
| Inputs, Type | | 8, Sinking | | | |
| Input Current @ 24 VDC | | 4mA | | | |
| Outputs, Type | | 8, FET | | | |
| Continuous Current/Channel | Amps | 0.5 | | | |
| Max Current | Amps | 0.5 | | | |
| Handle with Standard I/O (Q2 Model) | | | | | |
| Inputs, Type | | 2, Sourcing | | | |
| Input Current @ 24 VDC | | 60mA | | | |
| Outputs, Type | | 2, Relay | | | |
| Max Switch Current | Amps | 0.5 | | | |
| Max Available Current | Amps | 0.5 | | | |

Technical Specifications: Easy Arm Q2/iQ2

| Easy Arm Q2 & iQ2 | | | | |
|---|-------------------|---|--|--|
| Max Capacity | lb. [kg] | 165 lb [75kg] | 330 lb [150kg] | 660 lb [300kg] |
| Standard Crane Spans | ft [m] | 6 [1.83], 8 [2.44], 10 [3.05], 12 [3.66], and 14 [4.28] | | 8 [2.44], 10 [3.05], 12 [3.66], and 14 [4.28] |
| Standard Crane Height Under Hook (HUH) | ft [m] | 6 [1.83], 8 [2.44], 10 [3.05], and 11 [3.35] | | |
| Degree of Arm Rotation | | Primary Arm: 335° Secondary Arm: 325° | Primary Arm: 345° Secondary Arm: 325° | Primary Arm: 340° Secondary Arm: 310° |
| Arm Rotation Friction Brakes | | Yes | | |
| Max Lift Speed Unloaded | ft/min [m/min] | 195 fpm [59 mpm] | 95 fpm [29 mpm] | 45 fpm [14 mpm] |
| Max Lift Speed Fully Loaded | ft/min [m/min] | 120 fpm [37 mpm] | 60 fpm [18 mpm] | 40 fpm [12 mpm] |
| Max Float Mode Lift Speed | ft/min [m/min] | 110 fpm [34 mpm] | 55 fpm [17 mpm] | 40 fpm [12 mpm] |
| Max Lift Range | ft [m] | 11[3.4] | | |
| Max Lift Stroke | ft [m] | 8 [2.4] | | |
| Primary Voltage | VAC | Single Phase 220 +/- 10% | | |
| Maximum Current | Amps | 6 | | |
| Duty Cycle | | H5 | H5 | H4 H3 |
| Available Tooling Power | | 24VDC @ 0.5A | | |
| Lifting Media | | 3/16" dia. 19x7 Preformed Stainless Steel Wire Rope | | 1/4" dia. 7x19 Preformed Stainless Steel Wire Rope |
| Operating Temperature Range | °F [°C] | 41 – 122 [5 – 50] | | |
| Operating Humidity Range (Non-Condensing) | | 35 - 90% | | |
| Environmental Rating | | NEMA 5 | | |
| Weight Display Accuracy | | +/- 1% Rated Capacity | | |
| UL/CSA Certified | | YES | | |
| CE Certified | | YES | | |
| Actuator I/O (iQ2 Model) | | | | |
| Inputs, Type | | 8, Sinking | | |
| Input Current @ 24 VDC | | 6ma | | |
| Outputs, Type | | 4, FET | | |
| Continuous Current/Channel | Amps | 0.5 | | |
| Module Max Current | Amps | 0.5 | | |
| Handle with X67 I/O Module (iQ2 Model) | | | | |
| Inputs, Type | | 8, Sinking | | |
| Input Current @ 24 VDC | | 4mA | | |
| Outputs, Type | | 8, FET | | |
| Continuous Current/Channel | Amps | 0.5 | | |
| Max Current | Amps | 0.5 | | |
| Handle with Standard I/O (Q2 Model) | | | | |
| Inputs, Type | | 2, Sourcing | | |
| Input Current @ 24 VDC | | 60mA | | |
| Outputs, Type | | 2, Relay | | |
| Max Switch Current | Amps | 0.5 | | |
| Max Available Current | Amps | 0.5 | | |

Chapter 3 - Removal Procedure

If it has been determined that the G-Force® Q2 or iQ2 system must be returned to Gorbel or another authorized service location, or if the system is being relocated for some other reason, please follow the guidelines listed below:

1. Locate the original shipping box and materials or use a suitable alternative if necessary. Gorbel can provide a new shipping box upon receipt of a purchase order. Do not ship the unit anywhere strapped to a pallet or inside an empty box without any protection or packing material.
2. Disconnect any tooling or non-Gorbel® accessories including air hose fittings, external electrical switches, harnesses, etc. Do not send any of these items back unless specifically requested by Gorbel® After the Sale Service.
3. If possible, before powering off the system and disconnecting the control handle, raise the wire rope assembly to the upper limit.
4. Disconnect the coil cord assembly from both the actuator and the handle or swivel assembly. Pack these components carefully to avoid shipping damage (*diagram 1*).
5. If you are returning the system to Gorbel for service, upgrading, etc., mark the box clearly with the RMA (Return Material Authorization) number supplied by Gorbel® After the Sales Service (800-821-0086) and include a copy of the RMA in the box whenever possible. Do not send any components back to Gorbel without an RMA.
6. If you are returning the actuator from an Easy Arm system, you must unplug the twist lock power connection at the top of the mast and disconnect the communication cable that comes from the Arm assembly. Next, loosen the four M8 socket head cap screws that secure the actuator to the back of the Arm assembly and lift the actuator off the Arm assembly. If you are returning the handle and coil cord, you must disconnect them from the far end of the Arm assembly (*diagram 2*).

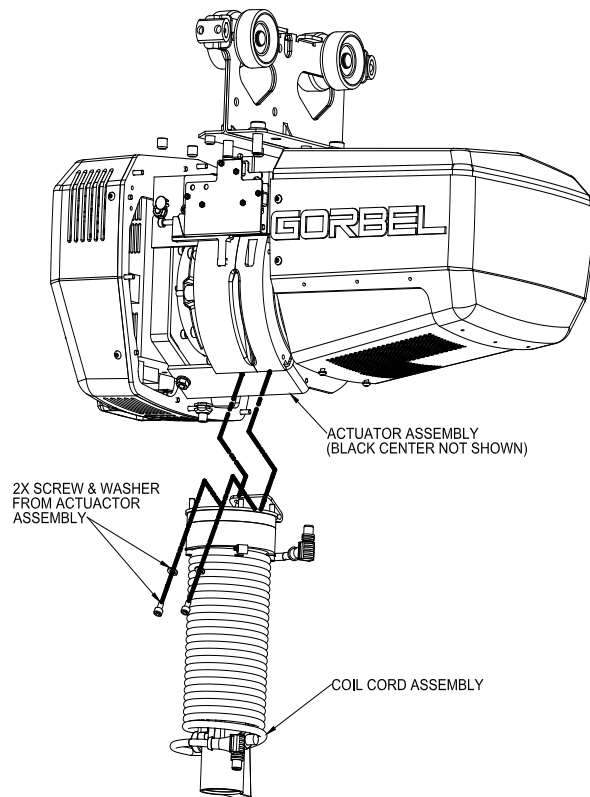

Diagram 1.

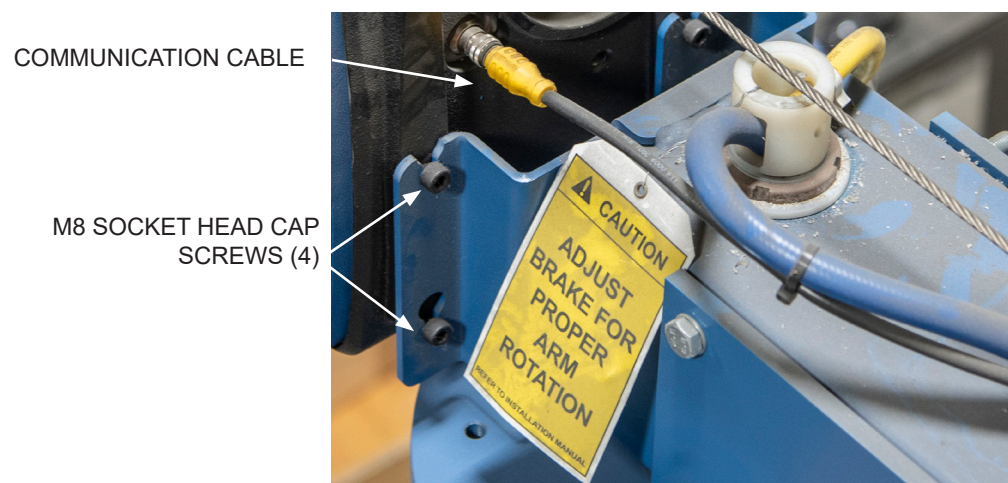

Diagram 2.

Chapter 4 - Controls and Programming

TIP: Complete Control and Programming Procedure can be found in the Program Mode sections of the G-Force or Easy Arm Q2 & IQ2 Installation, Operation & Maintenance Manual.

| Menu | Group Name | Sub-Group/Navigation | Parameter Name | Feature Description | Value |
|-----------------------|---|----------------------|------------------------|--|-------|
| Virtual Limits | <p>Overview: Configure operating limits without additional sensors, toggle between limits with Digital Inputs. Four (4) virtual limit sets are available with a standard Q2 or IQ2 unit. The Limits Sets 1 and 2 are programmable via the Handle Program Menu (where the set programmed is toggled with a preconfigured Digital Input). More virtual limit sets are possible to configure via the visualization or with custom programming.</p> <p>Gorbel® Recommends: The minimum distance between any two virtual limits to be no less than two (2) inches for best performance and user experience. Please note this distance is greatly dependent on Unit Speed, Responsiveness, Capacity, and Load, individual results may vary.</p> <p>Note: Gorbel® G-Force® & EasyArm® products are capable of achieving consistent positioning to 0.5 inches.</p> | | | | |
| | -- | -- | UPPER LIMIT | Keep the hook at the desired position and select to set the upper limit. | -- |
| | -- | -- | LOWER LIMIT | Keep the hook at the desired position and select to set the lower limit. Note: Setting the upper and lower virtual limits to the same position will cause the unit to not travel in either direction. | -- |
| | -- | -- | LOWER SLOW DOWN | Keep the hook at the desired position and select to set the lower slowdown limit. (When traveling downward the load slows down from max speed once crossing this limit). | -- |
| | -- | -- | UPPER SLOW DOWN | Keep the hook at the desired position and select to set the upper slowdown limit. (When traveling upward the load slows down from max speed once crossing this limit). | -- |
| | -- | -- | UPPER RESUME | Keep the hook at the desired position and select to set the upper resume limit. (When traveling upward the hook's speed increases from the upper slowdown speed to the regular speed at this position). | -- |
| | -- | -- | ADJUST SLOW DOWN SPEED | Allows one to set the speed of slowdown for both the upper and lower slow down limits. It first displays the current slowdown speed, and by toggling, one can select speeds from 5-50% of max speed (Multiples of 5) as set in the SPEED MENU. | 5-50% |
| | -- | -- | VL MENU RESET SETTINGS | Reset all programmed virtual limits in this menu. | -- |
| | RETURN TO MAIN MENU | | | Return back to the main selection menu. | -- |

| | | | | | | |
|---------------------|--|------------------------|------------------------------|--|---|-----------|
| Speed | Overview: Configure the speed that the hook travels. Note: An unloaded hook/tool will travel faster than a loaded one. | | | | | |
| | -- | -- | CURRENT SPEED XX% | Displays current speed as a percentage of the maximum speed available in the system. | Read-Only | |
| | -- | -- | SPEED MENU SELECT SPEED XX % | Maximum hoist speed selection, range of 10 – 100% corresponding to lowest and highest speed. Click on the menu button to cycle through various percentages and click on the G-Force button to select. | 10-100% | |
| | RETURN TO MAIN MENU | | | Return back to the main selection menu. | -- | |
| Response | Overview: Configure the lifting responsiveness or the acceleration setting. | | | | | |
| | -- | -- | CURRENT XXX | Displays the current response setting. (Medium by default) | Read-Only | |
| | -- | -- | RESPONSE | The handle control response options are defined as follows: Low = 75% of the maximum responsiveness setting Medium = 85% of the maximum responsiveness setting High = maximum responsiveness setting | LOW MEDIUM HIGH | |
| | RETURN TO MAIN MENU | | | Return back to the main selection menu. | -- | |
| FSH Shortcut | -- | -- | FAST ZERO FSH | This menu provides a short cut to tare the Force Sensing Handle. Clicking the Float Mode button will perform the tare process. NOTE: This menu will not be displayed unless a Force Sensing Handle is connected. | -- | |
| Settings | Overview: Configure settings to fine tune the G-Force® to the application. Adjustments to Float mode, User Overload, Idle Timers, and Force Sensing Handle settings can be made within. | | | | | |
| | -- | -- | ZERO WEIGHT DISPLAY | Record and tare (zero) the current lifted weight. | -- | |
| | -- | -- | WEIGHT READ | Toggle between enabling and disabling the load weight display. Once enabled, weight is displayed two seconds into standard operation (unit idling). | ON_ OFF | |
| | -- | -- | DISPLAY | Toggle the unit of the weight readout display between pounds (English) and kilograms (Metric). | METRIC ENGLISH | |
| | FLOAT MODE SUB-MENU | -- | | ENABLE/DISABLE FLOAT MODE | Enable/Disable running Float Mode related features, such as Standard Float Mode, Remote-Mount Float Mode Trigger, Dual Float Mode Weights, etc. | -- |
| | | FLOAT MODE ANTI-RECOIL | | AT OVER FORCE / SPEED | Startup screen when this sub-menu is accessed. The currently configured Anti-Recoil detection method is displayed (see next item for details on the detection methods). | Read-Only |

| | | | | | |
|----------|------------------------------|------------------------|---|---|------------------------------|
| Settings | FLOAT MODE SUB-MENU | FLOAT MODE ANTI-RECOIL | TO OVER FORCE/ SPEED | <p>Toggle Anti-Recoil detection method between standard over-speed and over-force detections. Anti-Recoil protects against a dropped weight while running Float Mode which would cause the unit to speed upward until hitting an object or a push force equivalent to the dropped weight.</p> <p>Over-Speed Detection: Unit terminates Float Mode if speed exceeds maximum Float Mode speed at 90% of unit loaded speed.</p> <p>Over-Force Detection: Unit terminates Float Mode if user's operating force exceeds the maximum force limit or a dropped weight is detected by evaluating the force profile. Different from Over-Speed Detection, unit can run at the maximum Float Mode speed.</p> <p>Note:</p> <ul style="list-style-type: none"> a. Maximum force limit defaults at 35 lbs. b. A dropped weight profile assumes the operator has both hands off the weight (tooling) as the unit speeds upward. Detection ability may reduce if user attempts to stop the unit or if the tooling swings heavily. <p>If the total lifted weight (e.g. tool and part) is less than the maximum force limit, Over-Speed Detection is applied.</p> | OVER FORCE OVER SPEED |
| | | | TURN ON SS CHECK | <p>Steady-State Check monitors the Hook's motion up or down at a set speed for a specific duration. If this condition is met the G-Force stops because of an anti-recoil event. The anti-recoil Max Force detection mode can now be adjusted via the MAX FORCE setting below once Turn ON SS Check is selected.</p> | -- |
| | | | MAX FORCE | <p>Set Anti-Recoil Over-Force Detection maximum force limit between 15 and 45 lbs. at 5 lb. increments.</p> <p>Note:</p> <ul style="list-style-type: none"> a. Anti-Recoil Over-Force Detection limits increased for 660 lb. units. Limits are between 30 and 90 lbs. at 5 lb. increments. b. Turn on SS Check for this Menu to be available. | 15-45lbs. |
| | | | DEFAULT SETTINGS | <p>Unit is reset to the default setup according to the configured detection method. For example, unit configured with Over-Force Detection defaults to 35 lbs. maximum force limit, dropped weight profile checkup and conditional Over-Speed Detection.</p> <p>Note:</p> <p>UNLOAD STOP option is turned off for both methods.</p> | -- |
| | RETURN BACK TO PREVIOUS MENU | | Return back to the Settings selection menu. | -- | |
| | RETURN TO MAIN MENU | | Return back to the main selection menu. | -- | |

| | | | | | | |
|----------|------------------------|------------------------------|------------------------------|--|--|----|
| Settings | FLOAT MODE SUB-MENU | -- | FLOAT MODE GAINS | Float Mode Gain Selection Sub-Menu. Selections from Lowest which is the least responsive but most stable, to High which is the most responsive and least stable. Note: Capacities less than 660lbs are not capable of adjusting these Gains and will only display: 'Does Not Apply'. | -DOES NOT APPLY -LOWEST -LOW -DEFAULT (MEDIUM) -HIGH | |
| | | RETURN BACK TO PREVIOUS MENU | | Return back to the Settings selection menu. | -- | |
| | | RETURN TO MAIN MENU | | Return back to the main selection menu. | -- | |
| | USER OVERLOAD SUB-MENU | CHANGE OVERLOAD LIMIT | AT OVLD LBS XXXX | Startup screen when this sub-menu is accessed. Displays the current overload limit. The G-Force® is overloaded approximately when the load exceeds the Overload Limit + the OP FORCE (Operator Force Limit). Note: This limit is superseded by the G-Force® capacity limit. | <i>Read-Only</i> | |
| | | | TARE OVLD LMT | When selected, unit tares the total lifted weight supported by the wire rope as the Overload Limit. Maximum Limit = Rated capacity plus 5 lbs. for G-Force® 165# and Easy Arm 165# models, or 101% of the rated capacity plus 5 lbs. for all other models. Minimum Limit = 25% of the rated capacity. Note: a. This can be monitored in Run Mode if "WT READ ON" is selected in the settings Menu. b. A warning is triggered if the tare weight is outside this range. | 41-170lbs 83-338lbs 165-672lbs 330-1338lbs | |
| | | | SET LIMIT LBS ##### | Set the Overload Limit to the selected ##### lbs. limit. How the maximum and minimum limit ranges are determined for the Overload Limit are shown above. Clicking the MENU pushbutton decrements the limit from the maximum, one lb. at a time. Press the G-Force® button to confirm selection. | See above | |
| | | | RETURN BACK TO PREVIOUS MENU | | Return back to the Settings selection menu. | -- |
| | | | RETURN TO MAIN MENU | | Return back to the main selection menu. | -- |
| | USER OVERLOAD SUB-MENU | CHANGE OPERATOR FORCE | AT FORCE LBS XXX | Startup screen when this sub-menu is accessed. Displays the current operator force. An operator's push and pull force is an extra loading to the system, especially when handle is mounted on the tooling. This sub-menu allows one to set a Force Limit to account for different user's operating force thus reducing chance of false overload detection. The limit should not be set larger than necessary as it reduces detection capability. | <i>Read-Only</i> | |
| | | | TO FORCE LBS ## | Set Operating Force Limit in 1 lb. increments. By default, the limit is set at 15 lbs. | 5-25lbs. | |

| | | | | | |
|-----------------|-------------------------|------------------------------|----------------------|--|---|
| Settings | USER OVER-LOAD SUB-MENU | RETURN BACK TO PREVIOUS MENU | | Return back to the Settings selection menu. | -- |
| | RETURN TO MAIN MENU | | | Return back to the main selection menu. | -- |
| | USER OVER-LOAD SUB-MENU | CHANGE SENSITIVITY | AT LEVEL X | Startup screen when this sub-menu is accessed. Displays the current overload detection sensitivity. The sensitivity parameter can be reduced to prevent false detection when operating a load at no greater than the Overload Limit. CAUTION: Do not reduce the sensitivity unless it is necessary due to actual usage. A reduced sensitivity increases the time to detect a legitimate overload condition that may result in damages to the unit. | Read-Only |
| | | | TO LEVEL X | Set Overload Detection Sensitivity to between 5 (HIGH) and 1 (LOW) one level decrements at a time. By default, the sensitivity is set at 5. | 1-5 |
| | | RETURN BACK TO PREVIOUS MENU | | Return back to the Settings selection menu. | -- |
| | | RETURN TO MAIN MENU | | | Return back to the main selection menu. |
| | TIMER SUB-MENU | HANDLE TIMER | AT LIMIT SEC ## MIN | The Idle Time Exceeded Warning timer setting for the slide and pendant handle run modes. | Read-Only |
| | | | SET LIMIT SEC ## MIN | Set the run mode Idle Time Exceeded timer by clicking the MENU pushbutton to increment the timer one second at a time. Press the G-Force® button to confirm selection. | 1-59s, & 1, 5, 10, 15m |
| | | FLOAT TIMER | AT LIMIT SEC ## MIN | The Idle Time Exceeded Warning timer setting for Float mode. | Read-Only |
| | | | SET LIMIT SEC ## MIN | Set the Float mode Idle Time Exceeded timer by clicking the MENU pushbutton to increment the timer one second at a time. Press the G-Force® button to confirm selection. | 1-59s, & 1, 5, 10, 15m |
| | | CUSTOM TIMER | AT LIMIT SEC ## MIN | The timer setting for custom motion such as Auto Home or another motion profile. | Read-Only |
| | | | SET LIMIT SEC ## MIN | Set the Custom timer by clicking the MENU pushbutton to increment the timer one second at a time. Press the G-Force® button to confirm selection. | 1-59s, & 1, 5, 10, 15m |
| | | RETURN BACK TO PREVIOUS MENU | | Return back to the Settings selection menu. | -- |
| | | RETURN TO MAIN MENU | | | Return back to the main selection menu. |
| | FSH HNDL SUB-MENU | -- | —FSH— DISABLED | Force Sensing Handle Menu will be disabled for all handles other than Force Sensing Handle | Read-Only |
| | | -- | ZERO FSH WEIGHT | Tare the FSH handlebar weight to zero the load cell signal. | -- |
| | | -- | CHANGE TO | Change FSH type to remote if current type is inline (or vice versa). | INLINE REMOTE |

| | | | | | |
|-------------------------------|---|---------------------------------|--------------------------------------|--|---------------------|
| Settings | FSH HNDL SUB- MENU | -- | SET FRCE TO | Change FSH Start up force to large if current setting is small (or vice versa). | LARGE SMALL |
| | | -- | DEADBAND CENTER | FSH deadband averaging to improve sensitivity of FSH signal by centering it. | -- |
| | | -- | DEFAULT SETTINGS | Apply default setting of FSH. | -- |
| | | RETURN BACK TO PREVIOUS MENU | | Return back to the Settings selection menu. | -- |
| | RETURN TO MAIN MENU | | | Return back to the main selection menu. | -- |
| | -- | -- | SETTINGS -RESET! | Reset all custom features in the settings menu | -- |
| | -- | -- | CLEAR RUN TIME | Reset the runtime – To remove service warning (Service Warning is setup on the Service Menu page of Program Menu on the HMI). | -- |
| | -- | -- | IP ADDRESS: | Displays the IP Address of the CPU. Refer to instructions in the appendices on connecting to the Access Point and accessing the Visual Interface via a VNC viewer. | XXX.XXX. XXX.XXX |
| | RETURN TO MAIN MENU | | | Return back to the main selection menu. | -- |
| ADVANCED SETTINGS | Overview: These menu options are available based on the I/O selection in the HMI; none will appear if there are no I/O points configured. Additional details can be found in the Input/Output Functionality section & Appendices of the Installation and Operation Manual. | | | | |
| | -- | -- | DUAL FLOAT MODE TOOL WEIGHT | Record tooling weight for the Dual Float Mode weights feature. | -- |
| | -- | -- | DUAL FLOAT MODE LOAD WEIGHT | Record tooling and load weights for the Dual Float Mode weights feature. | -- |
| | -- | -- | ANTI-DROP TOOL WEIGHT | Tare tooling weight for anti-drop feature. The minimum difference between unloaded and loaded tool weight is 20 lbs. for G-Force® and 25 lbs. for Easy Arm®. | -- |
| | -- | -- | MENU TO SET HOME | Program the auto home tracking position (load must be at desired position when setting). | -- |
| | RETURN TO MAIN MENU | | | Return back to the main selection menu. | -- |
| LANGUAGE SELECTION | | | | | |
| | | | | | |
| | | | | | |

Chapter 5 - Software Field Upgrade

1. Purpose

This procedure describes steps to field upgrade the software on the G-Force® Q2 and iQ2 products.

2. Scope

This procedure applies to both Q2 and iQ2 G-Force® and Easy Arm® products.

3. Prerequisites

SAFETY WARNING: Activities described in this procedure can cause personal harm. The minimum personal protective equipment (PPE) that must be worn at all times include safety glasses with side shields and safety shoes. Additional PPE required for specific activities will be noted in the instruction.

Tools Used:

- Memory stick (Suggested: SanDisk UltraFlair Series: SDCZ73-016G-G46, Minimum capacity 1GB).
- Software Upgrade files supplied by Gorbel® AtSS.
- Laptop with WiFi connectivity (or RJ45 port and Cat5 Ethernet cable).
- VNC Viewer software tool installed on computer.
- Q2 or iQ2 G-Force® / Easy Arm®.
- 220VAC Power Supply to the G-Force®.

4. Responsibilities

Operator, Production Supervisor, Assembly Technician, Robotics Engineer and Electrical Engineer.

5. Procedure

5.1 Updating New Software from V2.0.1 and up

- Copy the content of the folder update_installer_V2.X.X to a USB Flash Drive.
The USB must contain only this as content: Default_X20CP04xx folder and arnbcfg.xml file (Refer below)

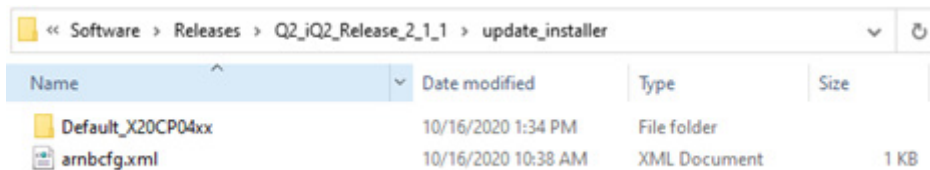

| Name | Date modified | Type | Size |
|-------------------|---------------------|--------------|------|
| Default_X20CP04xx | 10/16/2020 1:34 PM | File folder | |
| arnbcfg.xml | 10/16/2020 10:38 AM | XML Document | 1 KB |

- Plug in the USB Flash Drive into the USB port in the G-Force® service door (**Ref: Fig 1**)
- Power down the G-Force®.
- Power back up the G-Force®.
- The system reboots multiple times to install the Software.
- Once the Handle Screen displays a message “LIFT READY” or “E-STOP ENGAGED”, remove the USB.

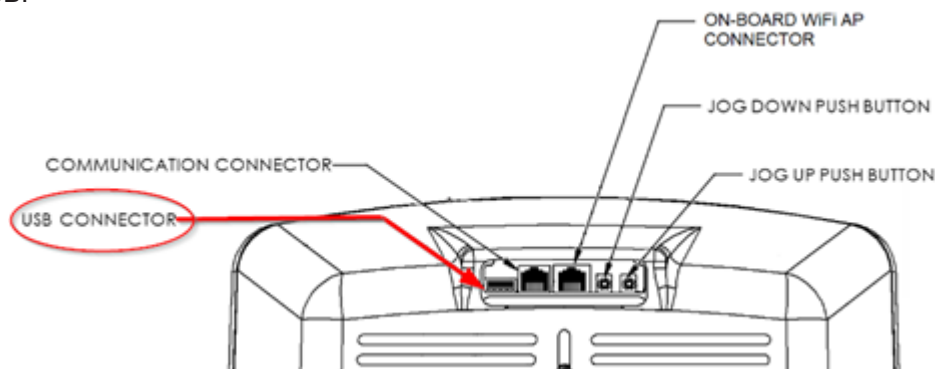

Figure 1: USB port

- Connect to the G-Force® AP (See Appendix C for instructions on connecting to the AP) at the G-Force® IP Address 192.168.105.26 on the VNC viewer.

Need a VNC Viewer Program? Gorbel® recommends the B&R VNC Viewer (See Appendix B for instructions to install).

- In the HMI Visualization login page, see the top right corner for SW Version, and verify that it matches the desired upgrade.

5.1.1 Verifying that the right configuration exists

- Inside the VNC Viewer click the **System Config** tab on the left pane of the Visualization to open the configuration page.
- Verify that the Manual Configuration is populated correctly.
- If not configured, click on **Import From Selected** (Ref: Fig 2 – Red Circle), to apply all the configuration settings that were previously set before the software upgrade (Make sure it is **factory_XXXXXX_c.xml** file for calibration values to be set back).
- Restart the G-Force® to apply the settings. (Ensure that USB drive has been removed before this step).

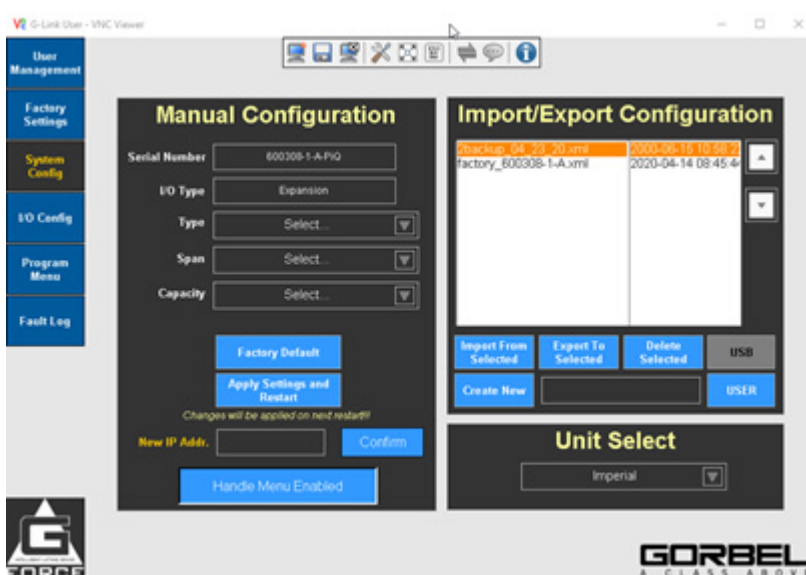

Figure 2: System Configurations Page - Import

5.2 Updating New Software from V2.0.0

5.2.1 Copying current configuration to the USB

- Power on the G-Force®.
- Plug in the USB Flash Drive into the USB port in the G-Force® service door (Ref: Fig 1)
- Connect to the G-Force® AP (See Appendix C for instructions on connecting to the AP) at the G-Force® IP Address 192.168.105.26 on the VNC viewer.
- Need a VNC Viewer Program? Gorbel® recommends the B&R VNC Viewer (See Appendix B for instructions to install).
- In the HMI Visualization click the **System Config** tab on the left pane of the screen to open the configuration page.
- Click on **USB** (Ref: Fig 3 – Green Circle) to select the USB Flash Drive.
- Click on the text field (Ref: Fig 3 – Red Box) and, using the popup keyboard, Name the file “back-up_mm_dd_yy” for easy identification later.
- Click on **Create New** (Ref: Fig 3 – Red circle) to create a backup for all the currently set configurations. (This backup will be saved in the Flash Drive that is plugged into the Actuator).

Note:

You can verify the configuration backup file was created successfully by removing the flash drive from the G-Force and checking on a computer to ensure that the newly created file, “*backup_mm_dd_yy*”, is there.



Figure 3: System Configuration Page - Create Backup

5.2.2 Software Upgrade

- Copy the content of the folder initial_install_V2.X.X to a USB Flash Drive. The USB must contain only this as content: Default_X20CP04xx, Default_X20CP04xx_RemoteInstall folder and arnbcfg.xml file. (Refer below)

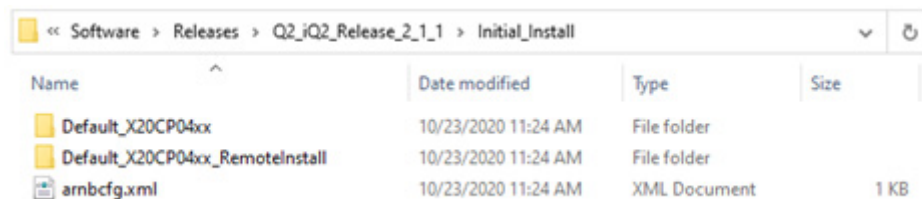

- Power down the G-Force and ensure the Flash Drive with the Software upgrade file is in the USB service port (Ref: Fig 1).
- Power up the G-Force®. The CPU will be automatically updated. During this process, the CPU will reboot at least once (LEDs will flash off). There is no other visual feedback that the USB update is in progress. When the handle reads G-Force Ready to Lift, it indicates the update is complete.

5.2.3 Updating the configuration from the backup

- Inside the VNC Viewer click the System Config tab on the left pane of the Visualization to open the configuration page.
- Click on **USB** (Ref: Fig 4 – Green Circle) to see the available configuration files.
- Use the **Up** and **Down Arrow Keys** (Ref: Fig 4 – Green Box) to choose the file created in step 5.1 named similar to “*backup_mm_dd_yy*” (Ref: Fig 4 – Red Box).
- Click on **Import From Selected** (Ref: Fig 4 – Red Circle), to apply all the configuration settings that were previously set before the software upgrade.
- Restart the G-Force® to apply the settings.



Figure 4: System Configuration Page - Import

- In the HMI Visualization login page, see the top left column for SW Version, and verify that it matches the desired upgrade.

6. References

Refer to Appendices: Appendix B - AP VNC Viewer Install Instructions, & Appendix C - AP Connection Quick-Start Guide.

7. Definitions

N/A

This page is intentionally left blank.

Chapter 6 - Troubleshooting

Troubleshooting Procedure

If your system does not appear to be functioning properly, review the following to help you identify which section of this chapter to refer to.

- A. If you are unfamiliar with how the system is supposed to operate, read the G-Force® Operational Guidelines, Lift Functionality and Program Mode sections of the **G-Force® Q2 and IQ2 Series Installation and Operation Manual**.
- B. If the system has a functional failure such as the system does not move in one direction, Float Mode does not work or you have a blank OLED screen on the control handle, refer to Troubleshooting Section I: **Functional Failure Table** in this chapter of the Service Manual.
- C. If you have a message or fault displayed on the OLED screen on the control handle, refer to Troubleshooting Section II: **System Fault Diagnostic Chart** in this chapter of the Service Manual.
- D. If there is something visually wrong such as a damaged wire rope, damaged coil cord or something obviously broken or out of position, refer to **Chapter 9 - Parts and Assembly** in this Service Manual to identify the correct orientation or replacement criteria for any component.
- E. Refer to the LED Chart on the following page for different machine states.

If none of the above statements described your problem, contact your Gorbel® distributor first, or Gorbel® After the Sales Service at 800-821-0086, for assistance. Please have your system serial number available when you call. It can be found on a label on the bottom of the actuator or on the bottom of the control handle. Refer to the pictures below for the location of the serial number label.



Actuator Label



Handle Label

Serial Number Label location

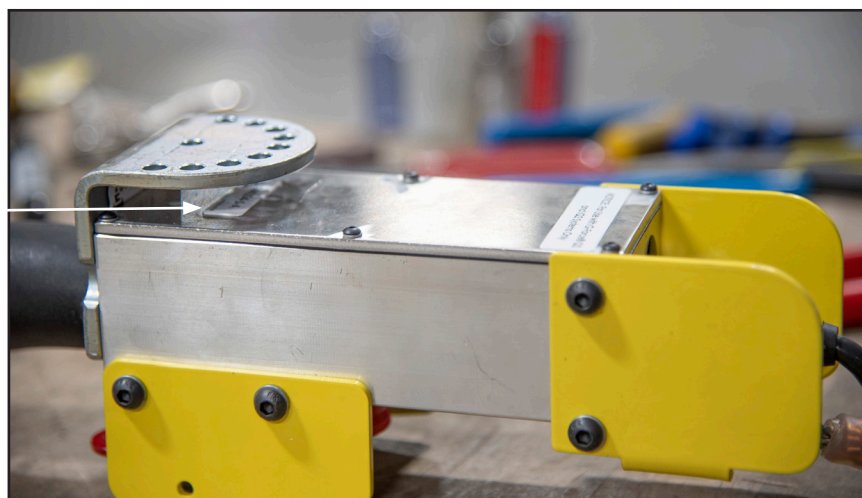

LED Chart: The chart below shows the status of LED lights in different states.

| Machine State | Sub-State (if applicable) | Color | LED TEXT |
|--|---------------------------|----------------|---|
| E-Stop Engaged | -- | No Light | E-STOP ENGAGED |
| Programming Mode | | Amber | PROGRAMMING MODE |
| PLC (Command) Fault | | Flashing Red | COMMAND FAULT ERROR NUMBER: #### |
| Drive Fault | | Flashing Red | DRIVE FAULT ERROR NUMBER: ##### |
| Warning | | Amber | WARNING #### |
| Service Warning | | Amber | SRV WARN <###> HRS |
| Service Mode | | Amber | SERVICE MODE |
| Run Mode | Overload | Red | WARNING LIFT OVERLOAD |
| | Overspeed | No Light | FLOAT MODE OVERSPEED |
| | Handle Idle Timeout | Amber | IDLE TIME EXCEEDED |
| | Handle Mode | Green | RUN MODE HANDLE |
| | Float Mode | Blue | RUN MODE FLOAT |
| Ready Mode | -- | No Light | G-FORCE READY TO LIFT |
| Startup Sequence | Before Ready Mode | No Light | SYSTEM BOOTING COMMUNICATION INITIALIZ- ING POWERED ON |
| G-Force Initializing | -- | No Light | G-FORCE INITIALIZING |
| User is connected to the unit with user interface* | | Flashing Amber | HMI USER INTERFACE IS ACTIVE |

*Service level 2 or OEM level 3 user is logged in.

Troubleshooting Section I: Functional Failure Table

| # | Functional Failure | Possible Cause(s) | Suspect Component(s) | Location (page reference) | Corrective Action |
|---|---|---|---|---------------------------|---|
| 1 | Blank handle display | Handle Mother Board Failure | Damaged / defective mother board | | Replace slide or pendant handle mother board |
| | | Communication Failure | G360 | | Clean or replace slip rings |
| | | | Handle failure | | Repair or replace handle |
| | | | Broken or damaged coil cord or connector | | Repair or replace coil cord |
| | | | Loose connector (any applicable cable connection) | | Repair or tighten connector |
| | | | Incorrect cable | | Replace cable with correct part |
| | | | Drive fault | | Refer to Drive Fault tables |
| | | | PLC (CPU) failure | | Replace PLC (CPU) |
| 2 | Handle display reads: ##### ##### | System network communication to the handle is lost. | G360 | | Clean or replace slip rings |
| | | | Handle mother board | | Replace slide or pendant handle mother board |
| | | | Any CAN bus cable or connection inside actuator or handle | | Repair or replace cable |
| | | | Coil cord or pendant cable | | Repair or replace coil cord or pendant cable |
| | | | PLC (CPU) failure | | Replace PLC (CPU) |
| 3 | No Actuator LEDs | AC power cable | Damaged or defective power cable | | Repair or replace AC power cable |
| | | Drive power cable | Damaged or defective drive cable | | Replace drive cable |
| | | DC power | Damaged or defective 24 VDC power supply or wiring | | Repair wiring, replace DC power supply |
| | | Drive LED | Damaged or defective LEDs on the ACOPOS drive | | Replace the ACOPOS drive |
| | | Cable or connection | Loose or disconnected cable (80163) | | Repair or replace cable assembly |
| | | ACOPOS | ACOPOS failure | | Replace ACOPOS |
| 4 | Unit will not move up or down with handle | Limit switches | A limit switch is actuated | | Jog the unit off the switch |
| | | | A limit switch is broken | | Replace the limit switch |
| | | | Switch wiring to Actuator board is disconnected or broken | | Repair the wiring or connection |
| | | | Upper and Slack Limit Switches are active concurrently. (Usually occurs only with suspended Pendants or when handles are changed out) | | Add weight to the swivel hook, cycle the system power. Use the down jog button to move the load off the upper limit switch. |
| | | Fault present | Varies | | Refer to Section II |
| | | | Handle mother board failure | | Replace slide or pendant handle mother board |

| | | | | | |
|-------------------|------------------------------------|----------------------------|--|--|--|
| | | Handle failure | Handle operator present sensor failure | | Repair or replace operator present sensor |
| | | | Broken linear transducer core | | Repair or replace linear transducer core |
| | | | Any loose connector | | Repair or tighten connections |
| | | | CAN bus | | Repair or replace CAN bus cables |
| | | | E-stop switch | | Repair or replace E-stop switch |
| | | | Mechanical handle failure | | Repair or replace handle |
| | | Coil cord or pendant cable | Broken cable | | Replace cable |
| | | | Loose connector | | Retighten connection |
| | | | Incorrect cable | | Replace with correct cable |
| | | Operator error | Virtual limits set incorrectly | | Check / reset virtual limits |
| | | Cable connection | Loose or disconnected cable (80167) | | Reconnect/retighten cable connection |
| | | ACOPOS Drive Fault | See drive fault # to identify cause, e.g.: <ul style="list-style-type: none"> • input drive fluctuation • drive overcurrent • drive or motor over-temperature • broken or loose motor cable • broken or loose encoder cable | | Follow the recommended remedy for each fault |
| PLC (CPU) failure | PLC (CPU) locked up in error state | | Replace the PLC (CPU) | | |

| | | | | | |
|---|---|---------------------|--|--|--|
| 5 | Unit will not move up or down in Float Mode | Feature not enabled | Software not configured | | Unlock feature in visualization software |
| | | Loadcell cable | Loadcell cable to main PCB disconnected or damaged | | Reconnect or replace loadcell |
| | | Loadcell | Loadcell is damaged or defective | | Replace loadcell |
| | | Loadcell pin | Loadcell pin is damaged / defective | | Repair / replace loadcell pin |
| | | Handle pushbutton | Pushbutton or switch is broken | | Replace handle mother board |
| | | Cable connection | Loose or disconnected cable (80167) | | Repair or replace the cable |

| | | | | | |
|---|-------------------------------------|----------------------------|--|--|--|
| 6 | Unit only moves in the up direction | Handle failure | Handle mother board failure | | Replace handle mother board |
| | | | Linear transducer failure | | Repair linear transducer |
| | | Coil cord or pendant cable | Broken conductor | | Repair or replace coil cord or pendant cable |
| | | Actuator wiring | Broken conductor | | Repair or replace cable |
| | | Down limit switch | Limit switch failure | | Replace down limit switch |
| | | Operator error | Falsely programmed lower virtual limit, under dual VL setup | | Check / reset virtual limits |
| | | | Falsely activating a custom feature that stops all downward movement | | Avoid this condition |

| # | Functional Failure | Possible Cause(s) | Suspect Component(s) | Location (page reference) | Corrective Action |
|---|--|--|--|---------------------------|--|
| 7 | Unit only moves in the down direction | Handle failure | Handle mother board failure | | Replace handle mother board |
| | | | Linear transducer failure | | Replace linear transducer |
| | | Coil cord or pendant cable | Broken conductor | | Repair or replace coil cord or pendant cable |
| | | Actuator wiring | Broken conductor | | Repair or replace cable |
| | | Up limit switch | Limit switch failure | | Replace up limit switch |
| | | Operator error | Falsely programmed upper virtual limit, under dual VL setup | | Check / reset virtual limits |
| | | | Falsely activating a custom feature that stops all upward movement | | Avoid this condition |
| Float Mode: loadcell maximum capacity reached | | | Decrease load | | |
| 8 | Load continues to drop after handle is released | Handle linear transducer | Linear transducer failure | | Replace linear transducer |
| | | | Linear transducer adjustment | | Adjust linear transducer |
| | | Handle mother PCB | Damaged / defective handle mother board | | Replace slide or pendant handle mother board |
| | | Handle operator present sensor | Damaged operator present sensor: falsely keep unit running | | Replace operator present sensor |
| | | Motor brake | Damaged / defective motor brake | | Replace motor |
| | | Operation | Custom feature: input to Auto Move falsely turned on | | Avoid this condition |
| 9 | Jog switches not functioning | Actuator PCB | Damaged / defective actuator PCB | | Replace actuator main PCB |
| | | Drive module | Damaged / defective drive module | | Replace ACOPOS drive module |
| | | Module cable | Damaged / defective drive cable | | Replace the cable |
| | | Cable connection | Loose or disconnected cable (80163) | | Replace motor drive cable |
| 10 | Unit moves noticeably faster in one direction than the other | Handle linear transducer | Linear transducer failure | | Replace linear transducer |
| 11 | Float Mode is not smooth and/or weight readout is inaccurate | Coil cord wear ring is binding inside actuator opening | Coil cord bracket is bent or out of position | | Replace or reform coil cord bracket |

| # | Functional Failure | Possible Cause(s) | Suspect Component(s) | Location (page reference) | Corrective Action |
|----|---|---|--|---------------------------|---|
| 12 | Constant "E-Stop Engaged" Message | Communication failure | Any communication interruption between the E-stop switch and the servo drive | | Check all applicable connections: handle, coil cord, G360™ |
| | | E-stop switch failure | E-stop switch | | Replace the E-stop switch |
| 13 | "Excessive Pause" Message | Operator present sensor is blocked for more than 60 seconds | Sliding Handle: Operator present sensor Pendant Handle: Either lever | | Clean the sensor and remove any blockage Look for interference with the levers |
| 14 | Air Leaking at Swivel Assembly | O-rings are worn or under-sized | O-rings | | Replace the o-rings and lubricate with general purpose non-synthetic grease |
| 15 | Weight readout is not accurate (within 1%) and/or Float Mode is "jumpy" | Load plate movement is restricted | Coil cord bracket and/or nylon wear rings out of position | | Check for bent coil cord bracket or nylon wear ring is not positioned correctly |

Troubleshooting Section II: System Fault Diagnostics Chart

A system fault or warning message may appear on the OLED screen on the G-Force® handle along with LEDs flashing. The system fault or warning message can be one of the following:

- A. **Command faults** – CPU detected condition while executing a command that results in a system shutdown. A message will display on the OLED screen with the Fault code.
- B. **ACOPOS Drive faults** – Drive detected condition that results in a shutdown. A message will display on the OLED screen with the Drive Fault code.
- C. **Command warnings** – CPU detected condition that will allow the system to continue to operate. A message will display on the OLED screen until the condition is cleared in Program Mode. **Note:** The warning is cleared through Program Mode or cycling the power or E-stop if the warning condition has been resolved.

The recovery from these may require the cycling off/on of the E-stop switch or AC power source.

Note: The latter must be done by disconnecting the AC power cord, using an electrical disconnect device or a circuit breaker.

It is also possible that the fault clearance may require a more specific corrective action such as replacing the wire rope, checking certain external input/output modules or some other service-related task. If necessary, check with your Gorbel® distributor or contact Gorbel® After the Sales Service at 800-821-0086 for assistance.

Q2-iQ2 Unit Fault/Error/Warning Categories

A. Command Faults

| Sub-Category | Fault Examples |
|----------------------------------|--|
| 1. Unit Configuration Setting | Mismatched configuration settings |
| 2. Supplemental tools | Problem saving configuration settings |
| 3. Hardware ID | Drive not ready to run |
| 4. Control Parameter Database | Digital input or output location outside range |
| 5. Other Status | Both travel limits are triggered during power up |
| 6. Custom Motion Control | Multiple Virtual Limit zones detected |
| 7. Motion Command Watchdog Timer | A Run Mode process causes system to hang up |

B. ACOPOS Drive Faults

| Sub-Category | Description and Examples |
|--|---|
| 1. SPT Drive Command | PLC command to the drive, e.g. E#1 invalid parameter |
| 2. PLC Drive Communication | Communication and information exchange between the PLC and the drive, e.g. E#1004 communication network timeout |
| 3. CAN Communication | CAN communication condition, e.g. E#6015 received data in the CAN network is corrupted |
| 4. CPU Processing | CPU running, e.g. E#1016, CPU doing too much work |
| 5. Drive Error State | Drive in error state (E#4005) and other fault messages |
| 6. Position Encoder | Motor position sensor problem, e.g. E#7045 corrupted sensor data |
| 7. E-Stop Enable Input | E-stop signal integrity, e.g. E#6021 signal is turned off |
| 8. Input Power | Drive line voltage condition, e.g. E#7211 line power low |
| 9. System Setup | Software processing, e.g. E#32131 missing data |
| 10. Motor, Regen, and Junction Temperature | Motor temperature status, e.g. E#9010 motor overheat |
| 11. Motor Drive Over Current | Drive current status, e.g. E#9300 over current |
| 12. Not Handled | All other less common drive faults |

Multiple drive faults can occur at one time and are displayed serially on the OLED screen. The first displayed drive fault number is often the initial cause that lead to subsequent triggered faults and is thus a good indicator to the true cause. However, this is not always the case as E#4005 (Drive Error State category) always precedes other error numbers that are the cause(s) of the shutdown.

Users should identify the fault category corresponding to the drive fault number(s) as a quick reference to the potential type of problem encountered. User may attempt basic troubleshooting checkup or repair. For example, if the fault category is "CAN Communication", check all the cable wiring and connectors for loose connections. If the fault category is "Motor, Regen, and Junction Temperature", user can let the unit cool down before resuming using the unit.

C. Command Warnings

| Sub-Category | Warning Examples |
|-----------------------------|--|
| 1. Process and Display Mode | Loadcell maximum coeff out of range |
| 2. Motion Control | Programming Upper and Lower Virtual limit at the same position |
| 3. Service Mode | Wire rope replacement |
| 4. Fault Warning | Handle electronics generated fault |

Users should contact their dealer or Gorbel® After the Sales Service for additional support and any questions about the encountered problem, corrective action, or replacement parts.

Q2-iQ2 Fault/Error/Warning Code Corrective Actions:

A.1. Command Faults - Unit Configuration Setting

| Error #: | Description: | Reaction: | Cause/Remedy: |
|----------|--|--|---|
| 1—9 | At Startup PLC detected invalid/mismatched configuration settings in memory. | Lift program terminates processing to prevent running with an unconfigured or potentially faulty PLC unit. | Please contact Gorbel® After the Sales Service at 800-821-0086 or 585-924-6262. |

A.2. Command Faults - Supplemental Tools

| Error #: | Description: | Reaction: | Cause/Remedy: |
|---------------------------------|---|--|---|
| 100—105, 110—115, 120—122 | PLC detected a problem saving configuration settings in memory. | Lift program terminates processing to prevent running with an unconfigured or potentially faulty PLC unit. | Please contact Gorbel® After the Sales Service at 800-821-0086 or 585-924-6262. |

A.3. Command Faults - Hardware ID

Error #200 - ERROR_HW_ID_PLC_QUERY

Description: An error has occurred while identifying the PLC type and connected add-on modules, if any.

Reaction: N/A

Cause / Remedy:

- (a) Check if a PLC model CP 0482 is properly installed. If I/O is used, check if the other expansion cards such as DM 9324 are correctly attached.
- (b) Please contact Gorbel® After the Sales Service at 800-821-0086 or 585-924-6262.

Error #201 - ERROR_HW_ID_EXCESS_PLC_MODULE

Description: The PLC has identified more add-on modules than the maximum limit of 5.

Reaction: N/A

Cause / Remedy:

- (a) Check if PLC model CP 0482 has any add-on modules.
- (b) Check if PLC model CP 0482 has a DM 9324 add-on module.
- (c) Reboot the unit.
- (d) Please contact Gorbel® After the Sales Service at 800-821-0086 or 585-924-6262.
- (e) If problem persists, replace the component.

Error #202 - ERROR_HW_ID_DRIVE_NOT_READY

Description: At startup, 10 seconds after power cycling the system, the ACOPOS drive is still not ready for operation.

Reaction: Lift program terminates processing to prevent running with incorrect configuration setup.

Cause / Remedy: PLC is not communicating with the ACOPOS drive due to:

- i. Loose or disconnected communication PowerLink cable(s) in the system.
- ii. PLC Powerlink communication component is not working.
- iii. ACOPOS AC114 PowerLink communication card is not working.
- iv. Actuator Interface circuit board has bad PowerLink cabling connection.

Error #203 - ERROR_HW_MISMATCH_PLC

Description: At startup, found the identified PLC model type does not match any of the known models for this system.

Reaction: Lift program terminates processing to prevent running with an incorrect configuration setup.

Cause / Remedy: Check if the installed PLC controller is of model CP 0482, as labeled on its front cover.

- i. Replace the module if an installation error has indeed occurred.
- ii. Please contact Gorbel® After the Sales Service at 800-821-0086 or 585-924-6262.

Error #204 - ERROR_HW_MISMATCH_PLC_MODULE

Description: At startup, found the identified modules for CP 0482 PLC model do not match the known modules for this controller.

Reaction: Lift program terminates processing to prevent running with an incorrect configuration setup.

Cause / Remedy:

- (a) Confirm the digital IO module DM 9324 is installed with the CP 0482 controller.
- (b) If problem persists, replace the component.

Error #206 - ERROR_HW_MISMATCH_DRIVE_MODULE

Description: At startup, found the identified ACÖPOS plug-in modules do not match the known models for this system.

Reaction: Lift program terminates processing to prevent running with an incorrect configuration setup.

Cause / Remedy: The designed plug-in modules are AC114, AC122, and AC131. If this error occurs:

- (a) At least one unknown module is installed and should be removed.
- (b) If correct modules are installed, at least one of them cannot be identified, possibly due to a faulty component. Replace as necessary.

Error #207 - ERROR_HW_MOTOR_PAR_SETUP_FAULT

Description: At startup, the configuration of the motor settings of the unit is returned with an error.

Reaction: Lift program terminates processing to prevent running with an incorrect configuration setup.

Cause / Remedy: Please contact Gorbel® After the Sales Service at 800-821-0086 or 585-924-6262.

A.4. Command Faults - Control Parameter Database**Error #300 - ERROR_MACHINE_STYLE_INVALID**

Description: At startup, found the stored configuration setting has an invalid machine style (i.e. G-Force®, Easy Arm®, etc.) value.

Reaction: Lift program terminates processing to prevent running with an incorrect configuration setup.

Cause / Remedy: A critical configuration setting of the unit is corrupted or falsely set. Please validate the configuration shown on the CONFIG page of the visualization is correct then contact Gorbel® After the Sales Service at 800-821-0086 or 585-924-6262 for further instruction.

Error #301 - ERROR_MACHINE_EA_VERSION_INVALID

Description: At startup, found the stored configuration setting has an invalid Easy Arm® span and height version value.

Reaction: Lift program terminates processing to prevent running with an incorrect configuration setup.

Cause / Remedy: A critical configuration setting of the unit is corrupted or falsely set. Please validate the configuration shown on the CONFIG page of the visualization is correct then contact Gorbel® After the Sales Service at 800-821-0086 or 585-924-6262 for further instruction.

Error #302 - ERROR_MACHINE_CAPACITY_INVALID

Description: At startup, found the stored configuration setting has an invalid capacity selection value.

Reaction: Lift program terminates processing to prevent running with an incorrect configuration setup.

Cause / Remedy: A critical configuration setting of the unit is corrupted or falsely set. Please validate the configuration shown on the CONFIG page of the visualization is correct then contact Gorbel® After the Sales Service at 800-821-0086 or 585-924-6262 for further instruction.

Error #310 - ERROR_CONTROL_DATABASE_NOT_FOUND

Description: At startup, found the stored configuration setting has an invalid index value to the control setting database.

Reaction: Lift program terminates processing to prevent running with an incorrect configuration setup.

Cause / Remedy: Please contact Gorbel® After the Sales Service at 800-821-0086 or 585-924-6262.

Error #320 - ERROR_MULTI_FEATURES_PER_UNIT_CONFIGURATION

Description: At startup, found multiple Q2/iQ2 feature configuration settings are set to use the same digital input channel.

Reaction: Lift program terminates processing to prevent running with an incorrect configuration setup.

Cause / Remedy:

- (a) Use the extended error index number (S#) to identify which Q2/iQ2 feature contains the invalid setting (Refer to table at end of Command Fault Error list). Please review the configuration shown on the CONFIG I/O page of the visualization to correct the invalid setting.
- (b) Please contact Gorbel® After the Sales Service at 800-821-0086 or 585-924-6262 for further instruction.

Error #321 - ERROR_MULTI_FEATURES_PER_OUTPUT_CONFIGURATION

Description: At startup, found multiple Q2/iQ2 feature configuration settings are set to use the same digital output channel.

Reaction: Lift program terminates processing to prevent running with an incorrect configuration setup.

Cause / Remedy:

- (a) Use the extended error index number (S#) to identify which Q2/iQ2 feature contains the invalid setting (Refer to table at end of Command Fault Error list). Please review the configuration shown on the CONFIG I/O page of the visualization to correct the invalid setting.
- (a) Please contact Gorbel® After the Sales Service at 800-821-0086 or 585-924-6262 for further instruction.

Error #322 - ERROR_INPUT_CONFIGURATION_OUT_OF_BOUND

Description: At startup, found a Q2/iQ2 feature input channel configuration setting is outside the allowable range.

Reaction: Lift program terminates processing to prevent running with an incorrect configuration setup.

Cause / Remedy:

- (a) Use the extended error index number (S#) to identify which Q2/iQ2 feature contains the invalid setting (Refer to table at end of Command Fault Error list). Please review the configuration shown on the CONFIG I/O page of the visualization to correct the invalid setting.
- (b) Please contact Gorbel® After the Sales Service at 800-821-0086 or 585-924-6262 for further instruction.

Error #323 - ERROR_OUTPUT_CONFIGURATION_OUT_OF_BOUND

Description: At startup, found a Q2/iQ2 feature input channel configuration setting is outside the allowable range.

Reaction: Lift program terminates processing to prevent running with an incorrect configuration setup.

Cause / Remedy:

- (a) Use the extended error index number (S#) to identify which Q2/iQ2 feature contains the invalid setting (Refer to table at end of Command Fault Error list). Please review the configuration shown on the CONFIG I/O page of the visualization to correct the invalid setting.
- (b) Please contact Gorbel® After the Sales Service at 800-821-0086 or 585-924-6262 for further instruction.

Error #324 - ERROR_FALSE_SETTING_CUS_MULTIPLE_VL_SETS

Description: At startup, found invalid configuration setting(s) for the multiple virtual limit (VL) sets standard Q2/iQ2 feature.

Reaction: Lift program terminates processing to prevent running with an incorrect configuration setup.

Cause / Remedy:

- (a) Please review the configuration shown on the CONFIG I/O page of the visualization to correct the invalid setting.
- (b) Please contact Gorbel® After the Sales Service at 800-821-0086 or 585-924-6262.

Error #326 - ERROR_MISSING_INPUT_CHANNEL

Description: At startup, found an Q2/iQ2 feature is misconfigured, specifically a required digital input channel location is missing.

Reaction: Lift program terminates processing to prevent running with an incorrect configuration setup. Handle displays this command fault followed by an extended error index number (S#) referencing the Q2/iQ2 feature with the invalid setting.

Cause / Remedy:

- (a) Use the extended error index number (S#) to identify which Q2/iQ2 feature contains the invalid setting (Refer to table at end of Command Fault Error list). Please review the configuration shown on the CONFIG I/O page of the visualization to correct the invalid setting.
- (b) Please contact Gorbel® After the Sales Service at 800-821-0086 or 585-924-6262.

Error #327 - ERROR_MISSING_OUTPUT_CHANNEL

Description: At startup, found an iQ2 feature is misconfigured, specifically a required digital output channel location is missing.

Reaction: Lift program terminates processing to prevent running with an incorrect configuration setup. Handle displays this command fault followed by an extended error index number (S#) referencing the iQ2 feature with the invalid setting.

Cause / Remedy:

- (a) Use the extended error index number (S#) to identify which Q2/iQ2 feature contains the invalid setting (Refer to table at end of Command Fault Error list). Please review the configuration shown on the CONFIG I/O page of the visualization to correct the invalid setting.
- (b) Please contact Gorbel® After the Sales Service at 800-821-0086 or 585-924-6262.

Error #331 - ERROR_X67_1_IO_MASK_SETUP

Description: At startup, unit detects an error while configuring the first X67 spare IO module based on the configuration setting.

Reaction: Lift program terminates processing to prevent running with an incorrect configuration setup.

Cause / Remedy:

- (a) Use the extended error index number (S#) to identify which iQ2 feature contains the invalid setting (Refer to table at end of Command Fault Error list). Please review the configuration shown on the CONFIG I/O page of the visualization to correct the invalid setting.
- (a) Please contact Gorbel® After the Sales Service at 800-821-0086 or 585-924-6262.

Error #332 - ERROR_X67_2_IO_MASK_SETUP

Description: At startup, unit detects an error while configuring the second X67 spare IO module based on the configuration setting.

Reaction: Lift program terminates processing to prevent running with an incorrect configuration setup.

Cause / Remedy:

- (a) Use the extended error index number (S#) to identify which iQ2 feature contains the invalid setting (Refer to table at end of Command Fault Error list). Please review the configuration shown on the CONFIG I/O page of the visualization to correct the invalid setting.
- (b) Please contact Gorbel® After the Sales Service at 800-821-0086 or 585-924-6262.

Error #333 - ERROR_X67_3_IO_MASK_SETUP

Description: At startup, unit detects an error while configuring the third X67 spare IO module based on the configuration setting.

Reaction: Lift program terminates processing to prevent running with an incorrect configuration setup.

Cause / Remedy:

- (a) Use the extended error index number (S#) to identify which iQ2 feature contains the invalid setting (Refer to table at end of Command Fault Error list). Please review the configuration shown on the CONFIG I/O page of the visualization to correct the invalid setting.
- (b) Please contact Gorbel® After the Sales Service at 800-821-0086 or 585-924-6262.

A.5. Command Faults - Other Status**Error #501 - ERROR_BOTH_TRAVEL_LIMITS_AT_HOMING**

Description: At startup, both the upper and lower limit switches are triggered. This can inhibit the ACOPOS drive from properly setting its position.

Reaction: Lift program terminates processing because the drive cannot properly configure its position.

Cause / Remedy:

- (a) Check for any mechanical binding that could engage both the upper and lower limit switches.
- (b) Check if the limit switch cable is properly connected to the Actuator interface board.
- (c) Check for bad electrical connection or shorted wires from the switches.

A.6. Command Faults - Custom Motion Control**Error #1101 - ERROR_MORE_THAN_ONE_VL_ZONE_INPUT_DETECTED**

Description: If multiple virtual limit (VL) sets (Q2/iQ2 feature) are enabled then only one digital input can turn on at a time to select a VL set (does not apply to custom programs utilizing multiplexed inputs). This error is triggered when the unit detects that multiple inputs are turned on at the same time.

Reaction: Lift is shut down to prevent unit from falsely responding to a wrong set.

Cause / Remedy:

- (a) Check for any electrical problem on the switches or devices connected to the input channels to falsely turn on at the same time.
- (b) Check for the electrical connection to the input channels of the lift (DM 9324 IO block in the actuator or X67 expansion IO module or Handle I/O).
- (c) Check the mechanical setup to ensure that there are no overlapping sensors/conditions to trigger multiple VL zones simultaneously.
- (d) Faulty input channels in the DM 9324 IO block or X67 expansion IO module or Handle I/O.

Error #1102 - ERROR_MORE_THAN_ONE_AUTOHOME_TARGETS_DETECTED

Description: If multiple Auto Home commands (Q2/iQ2 feature) are triggered simultaneously. Only one digital input can turn on at a time to select Auto Home (does not apply to custom programs utilizing multiplexed inputs). This error is triggered when the unit detects that multiple inputs are turned on at the same time.

Reaction: Lift is shut down to prevent unit from falsely responding to a wrong set.

Cause / Remedy:

- (a) Check for any electrical problem on the switches or devices connected to the input channels to falsely turn on at the same time.
- (b) Check for the electrical connection to the input channels of the lift (DM 9324 IO block in the actuator or X67 expansion IO module or Handle I/O).

- (c) Check the mechanical setup to ensure that there are no overlapping sensors/conditions to trigger multiple Auto Home commands simultaneously.
- (d) Faulty input channels in the DM 9324 IO block or X67 expansion IO module or Handle I/O.

A.7. Command Faults - Motion Command Watchdog Timer

Error #1600 - ERROR_WATCHDOG_RUN_MODE

Description: While running through Jog, Handle, Float or other custom motion, a processing command has taken too long to execute.

Reaction: Lift is shut down if the excessive delay is caused by any problem in the lift.

Cause / Remedy:

- (a) Use the extended error index number (EXT#) to obtain the processing state when excessive delay has occurred.
- (b) Please contact Gorbel® After the Sales Service at 800-821-0086 or 585-924-6262 regarding this problem and the processing state information.

Q2-iQ2 Unit: A. Command Fault - Extended Error List (Software Version R2.00.0 & Higher)

| Command Fault (E#) | Command Fault Description | Extended Error Index Number (S#) * |
|--------------------|--|---|
| E320 | Multiple iQ2 features are configured to use the same digital input channels. | S1. Anti-Drop Safety Interlock (Load Cell) |
| E321 | Multiple iQ2 features are configured to use the same digital output channel. | S2. Anti-Drop Safety Interlock (Slack Switch) |
| E322 | An iQ2 feature input channel is set outside the allowable range. | S13. External Trigger to Stop Motion |
| E323 | An iQ2 feature output channel is set outside the allowable range. | S14. Auto Home |
| E326 | An Q2/iQ2 feature required digital input channel location is missing. | S26. Float Mode Setup |
| E327 | An Q2/iQ2 feature required digital output channel location is missing. | S27. Dual Float Mode |
| E1600 | While executing a Jog, Handle, Float, or other custom motion, a processing command is taking too long to execute. Please contact Gorbel Inc. with this error number. | S28. Float Mode Safety Check Setup |
| | | S41. Multiple Virtual Limit |
| | | S66. System Switches Output |
| | | S68. System Fault Output |
| | | S86. Service Warning Output |
| | | S101. Direct Input to Output |
| | | EXT# PLC state when this error is generated |

*S# is for the latter feature that triggers the fault.

B. ACOPOS Drive Faults**Error #_____ - ERROR_ACOPOS_FAULT**

Description: ACOPOS drive faults or warnings.

Reaction: Lift is shut down for all drive faults or warnings.

Cause / Remedy: ACOPOS drive fault. Please check the fault number displayed on the OLED screen for additional detail.

- Use the error number to determine Fault Sub-Category to begin troubleshooting.
- Please contact Gorbel® After the Sales Service at 800-821-0086 or 585-924-6262.

| Sub-Category | Error # |
|--|--|
| 1. SPT Drive Command | 1, 1003, 1017, 1018, 1021 |
| 2. PLC Drive Communication | 1004, 32011, 32061, 32189 |
| 3. CAN Communication | 6015, 6016 |
| 4. CPU Processing | 1016 |
| 5. Drive Error State | 4005 |
| 6. Position Encoder | 5034, 7045, 7046 |
| 7. E-Stop Enable Input | 6021, 6023, 6048 |
| 8. Input Power | 7211, 7215, 7217, 7219 |
| 9. System Setup | 32131 |
| 10. Motor, Regen, and Junction Temperature | 9002, 9010, 9030, 9031, 9040, 9070, 9071, 41011, 41031, 41041, 41070 |
| 11. Motor Drive Over Current | 9050, 9051, 9060, 9061, 9300, 41051, 41061 |
| 12. Not Handled | All others |

Most Common Drive Error States**Error #7219 – SERVO_DC_BUS_VOLTAGE**

Description: AC Supply Voltage is out of spec.

Reaction: Lift is shut down for all drive faults or warnings.

Cause / Remedy: Find a suitable AC voltage source, should be between 208 & 242VAC.

Error #32011, 32189 & 6015 – COMMUNICATION_FAILURE

Description: Communication is faulty on the G-Force®.

Reaction: Lift is shut down for all drive faults or warnings.

Cause / Remedy: On a powered down unit:

- (a) Verify all external and internal cabling is making contact and no wires are pinched, abraded or broken.
- (b) Inspect the G360® slipping swivel assembly. Clean and lubricate slipping (Deoxit) or replace if worn excessively.
- (c) Please contact Gorbel® After the Sales Service at 800-821-0086 or 585-924-6262.

C Command Warnings**Error #10000 - WARNING_LIFT**

Description: Starting index to non-critical warnings.

C.1. Command Warnings - Process and Display Mode**Error #10404 - WARN_PROG_ERROR_LOADCELL_COEF**

Description: This warning is generated when system attempts to program the load cell coefficient, as commanded through PROGRAM MODE \ CONFIGUR MENU \ CALIBRAT LOD COEF and resulted in an invalid setting number. **Reaction:** Handle OLED displays the warning while unit is allowed to continue to run. The invalid coefficient is cleared and all previously programmed weights for Q2 and iQ2 features are reset.

Cause / Remedy: Load cell calibration procedure composed of three steps: (1) zero the empty handle and any clevis or hook), (2) pick up a maximum capacity and set the load cell coefficient, and (3) set unit in slack and set a true zero weight. This error is generated when performing (2). The possible causes can be:

- (a) Step (1) is not correctly performed with an empty handle.
- (b) The pickup weight does not match the rated capacity.
- (c) The programming sequences are not followed correctly.
- (d) Problem with the load cell electronics. This may include a damaged load cell, loose load cell cable connection to the actuator main interface board or to the servo drive.

Error #10405 - WARN_PROG_OVER_RANGE_LOADCELL_BIAS

Description: The sampled minimum load cell signal (bias) is greater than the acceptable range from the normal bias value for this unit. The acceptable range of this parameter is empirically determined and selected for different models and capacities.

Reaction: Handle OLED displays the warning while unit is allowed to continue to run. The over-range warning indicates the potential error in programming the parameter without altering the value. The sample value is still retained.

Cause / Remedy: The load cell minimum signal (bias) is sampled during procedure steps (1) and (3) (see Warning #10404). However, the normal bias value selected is based on step (3), when the unit is in slack. Therefore, if a handle, tooling, or additional parts are tare in step (1), this warning will be triggered. Ignore this warning if it is triggered in step (1). If this warning is triggered while the unit should be in slack, the possible causes can be:

- (a) The unit may appear to be in slack while the load plate is still exerting pressure on the load cell. This may be due to some binding or drag in the rotary geartrain mechanism. Ensure the unit is in slack such that the rotary geartrain mechanism is pushed back (i.e. push up onto the white plastic wear ring at the bottom of the unit) and the unit cannot move down with a handle controller.
- (b) The metal mounting bracket of the white plastic wear ring may be bent such that the wear ring cannot move back far enough and is touching the cast housing opening prematurely. When the unit is loaded, the wear ring should be situated near the center of the circular opening without contact. The bracket may be bent back if it is offset near a particular side significantly. Readjust the bracket or replace it.
- (c) Problem with the load cell electronics. This may include a damaged load cell or loose load cell cable connection to the actuator main interface board or to the servo drive.
- (d) The actuator PCB board which processes the load cell signal may be damaged or out of spec. Replace the PCB board.

Error #10406 - WARN_PROG_OVER_RANGE_LOADCELL_COEF

Description: The sampled maximum load cell signal (coefficient) is greater than the acceptable range from the normal coefficient value) for this unit. The acceptable range of this parameter is empirically determined and selected for different models and capacities.

Reaction: Handle OLED displays the warning while unit is allowed to continue to run. The over-range warning indicates the potential error in programming the parameter without altering the value. The sample value is still retained.

Cause / Remedy: The load cell maximum signal (coefficient) is sampled during procedure step (2) (see Warning #10404). When this parameter is calibrated, the unit is expected to be loaded with a weight corresponding to the capacity of the unit. The possible causes can be:

- (a) Step (1) of the calibration procedure (see Warning #10404) is not correctly performed.
- (b) The pickup weight does not match the rated capacity.
- (c) The metal mounting bracket of the white plastic wear ring may be bent such that the wear ring is pressing against the cast housing opening. When the unit is loaded, the wear ring should be situated near the center of the circular opening without any contact. Readjust the bracket or replace it.
- (d) Problem with the load cell electronics. This may include a damaged load cell or loose load cell cable connection to the actuator main interface board or to the servo drive.
- (e) The actuator PCB board which processes the load cell signal may be damaged or out of spec. Replace the PCB board.

C.2. Command Warnings - Motion Control**Error #11000 - WARN_BOTH_TRAVEL_LIMITS_ENGAGED**

Description: Both the upper and lower travel limit switches are engaged at motion startup (i.e. handle, pendant, float mode, etc.). This warning can only trigger after the unit has powered up and is different from error #501.

Reaction: Motion not started and handle display warning on the OLED.

Cause / Remedy:

- (a) Check for any mechanical binding that could engage both the upper and lower limit switches.
- (b) Check and correct if the limit switch cable is connected to the interface board.
- (c) Check for bad electrical connection or shorted wires from the switches.

Error #11001 - WARN_UNCONTROLLED_MODE_SWITCH

Description: The current running control mode (RUN MODE) is switched to another unexpectedly or a Handle type miss-match is detected.

Reaction: Handle OLED displays the warning while unit is allowed to continue to run.

Cause / Remedy: When a control mode is started, the handle OLED displays the type of RUN MODE the unit is running at, e.g. HANDLE, PENDANT, or FLOAT MODE.

- (a) If the OLED displays the incorrect Handle type or Mode at any time that does not match the actual Handle type/Mode, the Handle motherboard may be damaged and should be replaced.
- (b) For all other cases, please contact Gorbel Inc. to describe the symptoms and if the problem is reoccurring.

Error #11003 - WARN_SLIDE_PENDANT_TYPE_IO_BOTH_OFF

Description: Slide or pendant handle sends a unique signal to the PLC to differentiate the handle type. This error is caught if none of them is received.

Reaction: Unit is stopped with a warning display.

Cause / Remedy: Replace the slide or pendant handle motherboard.

Error #11004 - WARN_UP_DOWN_V_LIMITS_AT_SAME_POSITION

Description: This warning is triggered when both the Upper and Lower Virtual Limits are attempted to be programmed to the same position, which would essentially stop all motion. This is done by checking if the distance gap between these two limits is less than 1". In other words, the Upper and Lower Virtual Limits must be at least 1" apart.

Reaction: Handle OLED displays the warning message and the virtual limit is not programmed.

Cause / Remedy: While this warning attempts to catch and prevent false setup, if it is unintentional, move the two virtual limit positions slightly apart and re-program the virtual limit(s).

Error #11005 - WARN_LOADCELL_DROP_BELOW_MINIMUM

Description: This warning is triggered when Float Mode detects load cell signal drops below a minimum level indicating an electronics problem.

Reaction: Handle OLED displays the warning message and Float Mode is terminated.

Cause / Remedy: This fault is typically triggered when the load cell cable or signal wire(s) is disconnected or damaged. Check for:

- (a) loose or damaged load cell cable to the main circuit board in the actuator
- (b) loose or damaged intermedium cable, P/N 78613, to the main circuit board or the load cell analog signal wire(s) on this cable to the drive
- (c) damaged main circuit board for processing the load cell sensor
- (d) damaged load cell sensor

Error #11006 WARN_UO_EXCEED_MAX_CAPACITY

Description: This warning is triggered when User Programmable Overload attempts to tare a weight larger than the maximum limit. The maximum limit is set at 101% of the rated capacity plus 12 lbs to account for the handle weight. **Reaction:** The overloaded tare weight is rejected, and the maximum limit is used to set up the overload detection parameters.

Cause / Remedy: When TARE OVLD LMT selection from USR OVLD SUB-MENU \ CHANGE OVLD LMT in PROGRAM MODE is selected, unit tares the current lifted weight and applies overload settings proportional to this weight. When this error occurs the maximum limit is applied instead of the tare value to prevent the User overload limit exceeding the maximum limit.

Please activate weight readout (WEIGHT READ ON_ under SETTINGS MENU in PROGRAM MODE) and ensure that the lifted weight does not exceed the maximum limit before selecting TARE OVLD LMT. This warning does not negatively affect system performance because overload parameters are set to the maximum allowable settings. User can cycle the E-stop switch on the handle to clear the warning.

Error #11007 WARN_UO_BELOW_MIN_LIMIT

Description: This warning is triggered when User Programmable Overload attempts to tare a weight less than 25% of the rated capacity.

Reaction: The tare weight is rejected and 25% of the rated capacity is used to set up the overload detection parameters.

Cause / Remedy: When TARE OVLD LMT selection from USR OVLD SUB-MENU \ CHANGE OVLD LMT in PROGRAM MODE is selected, unit tares the current lifted weight and applies overload settings proportional to this weight. When this error occurs the 25% rated capacity value is applied instead of the tare value to prevent the User overload limit being set below the minimum limit.

Please activate weight readout (WEIGHT READ ON_ under SETTINGS MENU in PROGRAM MODE) and ensure that the lifted weight is not below the minimum limit before selecting TARE OVLD LMT. This warning does not negatively affect system performance because overload parameters are set to the minimum allowable settings. User can cycle the E-stop switch on the handle to clear the warning.

Error #11008 WARN_SLIDE_PENDANT_TYPE_OI_MISMATCH

Description: Slide or pendant handle sends a unique signal to the PLC to differentiate the handle type. This error is generated if handle type signal changes from slide to pendant or vice versa while the unit is running.

Reaction: Unit is stopped with a warning display.

Cause / Remedy: Replace the slide or pendant handle mother board.

Error #11009 WARN_FSH_STARTUP_TARE_WEIGHT_MISMATCH

Description: The FSH load cell signal has deviated from zero with certain threshold value when unit is first booted up or e-stop is re-started.

Reaction: N/A

Cause / Remedy: Re-tare the FSH.

Error #11010 WARN_FSH_TARE_TIME_OUT

Description: Tare process time out. The tare process takes time longer than the threshold value. This problem indicates a communication problem during the tare process.

Reaction: N/A

Cause / Remedy: Contact Gorbel After the Sales Service if this command warning is repetitive.

Error #11011 WARN_FSH_TARE_INCORRECT

Description: This command warning indicates the handle weight attached to FSH load cell exceeds the maximum limit (25 lbs.) or the FSH load cell signal is not successfully transmitted from the FSH.

Reaction: N/A

Cause / Remedy:

- (a) Do not affix attachments to the handle segment of the inline Force Sensing Handle and re-tare.
- (b) Ensure the weight of the end-user custom handle attached to the Force Sensing Hub does not exceed 25lbs.
- (c) Check whether the FSH connection is good both on wire rope and load cell cable inside FSH.
- (d) Replace the handle, coil cord, actuator interface board, handle loadcell, and signal wires in the actuator until the fault is corrected

Error #11115 WARN_FM_TARE_BELOW_AR_FORCE

Description: Selected Anti-Recoil force higher than tared load.

Reaction: N/A

Cause / Remedy: Try to remove some weights out of handle attachments and re-tare the FSH. Check whether the FSH connection is good both on wire rope and load cell cable inside FSH.

C.3. Command Warnings - Maintenance Services**Error #11700 - WARN_REPLACE_WIREROPE_RECOMMEND**

Description: When cycle count and lower limits are set, cycle count can increment. This warning is triggered if the cycle exceeds 15000 counts.

Reaction: N/A

Cause / Remedy: This is a warning indicator to check wire rope condition under the most severe operating conditions for signs of wear and tear and it can vary based on the actual usage. Please examine the wire rope and replace if necessary. After replacement, activate Program Mode with the handle, browse to SERVICE MENU, and scroll to CLEAR COUNT selection to reset the cycle count to 0.

Error #11701 - WARN_REPLACE_WIREROPE_REQUIRED

Description: When cycle count and lower limits are set, cycle count can increment. This warning is triggered if the cycle exceeds 20000 counts.

Reaction: N/A

Cause / Remedy: This is a warning indicator to check wire rope condition under the most severe operating conditions when replacement may be necessary, and it can vary based on the actual usage. Please examine the wire rope and replace if necessary. After replacement, activate Program Mode with the handle, browse to SERVICE MENU, and scroll to CLEAR COUNT selection to reset the cycle count to 0.

C.4. Command Warnings - Fault Warning**Error #11800 - WARN_HANDLE_FAULT_NOT_ACTIVE**

Description: Handle digital IO CAN bus controller has triggered a Handle Fault and becomes inactive.

Reaction: The digital inputs such as the OPS sensor, Menu and Float pushbuttons are disabled. Access to Program Mode is disabled. Jog can be used to safely lower loads to allow troubleshooting.

Cause / Remedy: A fault, specifically an inactive node, can occur if the handle CAN bus controller does not communicate with the PLC correctly and exceeds the allowable wait period of the master node. Reboot the unit with the E-stop to clear the fault if it is not repetitive. Inaccurate communication can result from faulty handle board, noise or data corruption in the CAN communication wires, or any cut wires. Replace the handle, coil cord, actuator interface board, and CAN communication wires in the actuator until the fault is corrected.

Error #11801 - WARN_HANDLE_FAULT_CAN_IO_ALARM

Description: Handle digital IO CAN bus controller has triggered a Handle Fault and becomes inactive. Additional error information may be available following the warning.

Reaction: The digital inputs such as the OPS sensor, Menu and Float pushbuttons are disabled. Access to Program Mode is disabled. Jog can be used to safely lower loads to allow troubleshooting.

Cause / Remedy: A fault, specifically a CAN bus alarm, can occur if the CAN controller board does not communicate with the PLC correctly, is in a fault state, falsely removed, configuration memory error, etc. Reboot the unit with the E-stop to clear the fault if it is not repetitive. Problem can result from faulty handle board, noise or data corruption in the CAN communication wires, or any cut wires. Replace the handle, coil cord, actuator interface board, and CAN communication wires in the actuator until the fault is corrected.

Error #11802 - WARN_HANDLE_FAULT_BUS_OFF

Description: Handle digital IO CAN bus controller has been turned off unintentionally triggering a Handle Fault and becomes inactive. If a WARN_HANDLE_FAULT_NOT_ACTIVE warning does not occur together with this, then the bus line is turned off only briefly.

Reaction: The digital inputs such as the OPS sensor, Menu and Float pushbuttons are disabled. Access to Program Mode is disabled. Jog can be used to safely lower loads to allow troubleshooting.

Cause / Remedy: A fault, specifically bus off exception, can occur if the handle CAN controller does not communicate with the PLC correctly or at all. Reboot the unit with the E-stop to clear the fault if it is not repetitive. Inaccurate communication can result from faulty handle board, noise or data corruption in the CAN communication wires, or any cut wires. Replace the handle, coil cord, actuator interface board, and CAN communication wires in the actuator until the fault is corrected.

Error #11803 - WARN_OLED_FAULT_NOT_ACTIVE

Description: Handle OLED board CAN bus controller has triggered a fault and becomes inactive.

Reaction: Warning message on this fault may be on screen or by flashing LED. If the board has become inoperative, a factory default warning message may be displayed on the OLED screen. Access to Program Mode is disabled.

Cause / Remedy: A fault, specifically an inactive node, can occur if the handle OLED board CAN bus controller does not communicate with the PLC correctly and exceeds the allowable wait period of the master node. Reboot the unit with the E-stop to clear the fault if it is not repetitive. Inaccurate communication can result from faulty handle board, noise or data corruption in the CAN communication wires, or any cut wires. Replace the handle, coil cord, actuator interface board, and CAN communication wires in the actuator until the fault is corrected.

Error #11804 - WARN_OLED_FAULT_CAN_IO_ALARM

Description: Handle OLED board CAN bus controller has triggered an alarm status. Additional error information may be available following the warning.

Reaction: Warning message on this fault may be on screen or by flashing LED. If the board has become inoperative, a factory default warning message may be displayed on the OLED screen. Access to Program Mode is disabled.

Cause / Remedy: A fault, specifically a CAN bus alarm, can occur if the CAN controller board does not communicate with the PLC correctly, is in a fault state, falsely removed, configuration memory error, etc. Reboot the unit with the E-stop to clear the fault if it is not repetitive. Problem can result from faulty handle board, noise or data corruption in the CAN communication wires, or any cut wires. Replace the handle, coil cord, actuator interface board, and CAN communication wires in the actuator until the fault is corrected.

Error #11805 - WARN_OLED_FAULT_BUS_OFF

Description: Handle OLED board CAN bus controller has been turned off unintentionally. If a WARN_OLED_FAULT_NOT_ACTIVE warning does not occur together with this, then the bus line is turned off only briefly.

Reaction: Warning message on this fault may be on screen or by flashing LED. If the board has become inoperative, a factory default warning message may be displayed on the OLED screen. Access to Program Mode is disabled.

Cause / Remedy: A fault, specifically bus off exception, can occur if the handle CAN controller does not communicate with the PLC correctly or at all. Reboot the unit with the E-stop to clear the fault if it is not repetitive. Inaccurate communication can result from faulty handle board, noise or data corruption in the CAN communication wires, or any cut wires. Replace the handle, coil cord, actuator interface board, and CAN communication wires in the actuator until the fault is corrected.

Error #11806 - WARN_SPAREIO_FAULT_NOT_ACTIVE

Description: An X67 spare IO block CAN bus controller connected to the handle has triggered a fault and become inactive.

Reaction: Standard IQ2 features operating through this spare IO block are either disabled or outputs turned off.

Cause / Remedy: A fault, specifically an inactive node, can occur if an X67 spare IO block CAN bus controller does not communicate with the PLC correctly and exceeds the allowable wait period of the master node. Reboot the unit with the E-stop to clear the fault if it is not repetitive. Inaccurate communication can result from faulty handle board, noise or data corruption in the CAN communication wires, or any cut wires. Replace the handle, coil cord, actuator interface board, and CAN communication wires in the actuator until the fault is corrected.

Error #11807 - WARN_SPAREIO_FAULT_CAN_IO_ALARM

Description: An X67 spare IO block CAN bus controller connected to the handle has triggered an alarm status. Additional error information may be available following the warning message.

Reaction: Standard IQ2 features operating through this spare IO block are either disabled or outputs turned off. **Cause / Remedy:** A fault, specifically a CAN bus alarm, can occur if the CAN controller board does not communicate with the PLC correctly, is in a fault state, falsely removed, configuration memory error, etc. Reboot the unit with the E-stop to clear the fault if it is not repetitive. Problem can result from faulty handle board, noise or data corruption in the CAN communication wires, or any cut wires. It can also be triggered if a channel in the X67 spare IO module is configured as an output but 24Vdc is sent to this channel, for example, due to miss-wiring. Check and correct any wiring into a false channel or false custom feature configuration. Replace the handle, coil cord, actuator interface board, and CAN communication wires in the actuator until the fault is corrected.

Error #11808 - WARN_SPAREIO_FAULT_BUS_OFF

Description: An X67 spare IO block CAN bus controller connected to the handle has been turned off unintentionally. If a WARN_SPAREIO_FAULT_NOT_ACTIVE warning does not occur together with this, then the bus line is turned off only briefly.

Reaction: Standard IQ2 features operating through this spare IO block are either disabled or outputs turned off. **Cause / Remedy:** A fault, specifically bus off exception, can occur if the X67 spare IO block CAN controller does not communicate with the PLC correctly or at all. Reboot the unit with the E-stop to clear the fault if it is not repetitive.

Inaccurate communication can result from faulty handle board, noise or data corruption in the CAN communication wires, or any cut wires. Replace the handle, coil cord, actuator interface board, and CAN communication wires in the actuator until the fault is corrected.

Error #11809 - WARN_CANIO_FAULT

Description: The CAN bus controller fault checking routine has experienced an error or the detected failed CAN bus board has a node number outside the designed range of the system.

Reaction: N/A

Cause / Remedy: This warning occurs if the routine itself experiences a fault such as unconfigured bus, node or even application. User should reboot the unit with the E-stop to clear the fault if it is not repetitive. Replace the handle, coil cord, actuator interface board, and CAN communication wires in the actuator until the fault is corrected. If the problem cannot be resolved, contact Gorbel® After the Sales Service at 800-821-0086 or 585-924-6262 for further diagnostic and troubleshooting information.

NOTE!

If you are experiencing an error code that is not listed in this publication, please contact Gorbel's After the Sales Service at 1-800-821-0086 or 585-924-6262.

Hint: Google "ACOPOS ERROR CODES" for a complete listing of codes, however, some may not apply to this system configuration.

Chapter 7 - Electrical Schematics

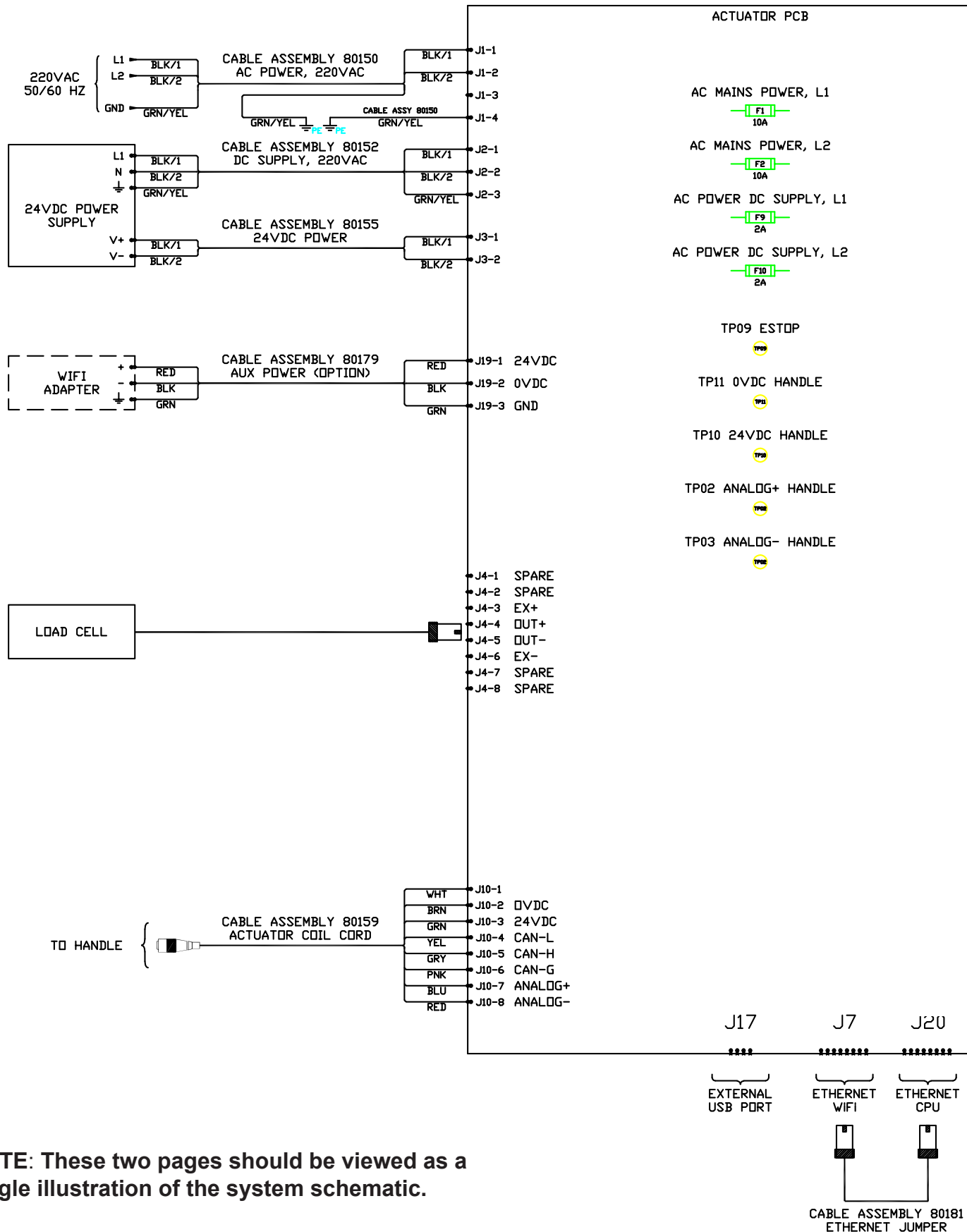

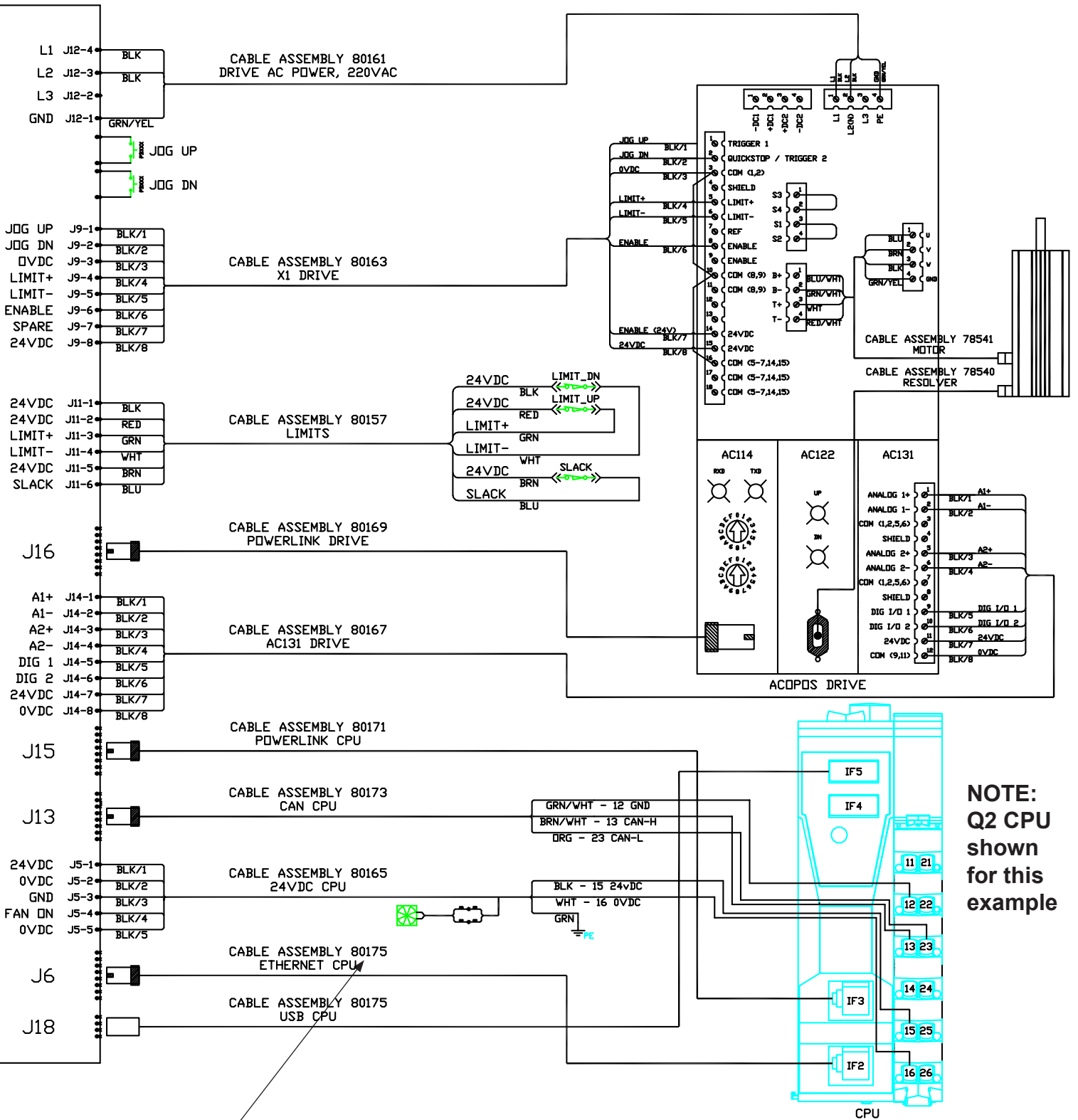

NOTE: The 5 digit numbers represent the replacement part numbers for the individual wiring harnesses (with connections where applicable).

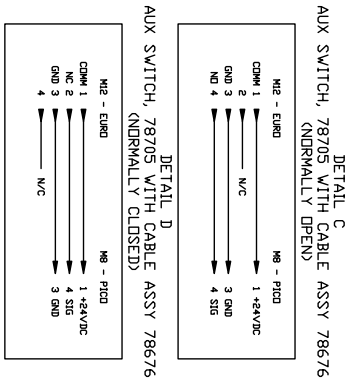
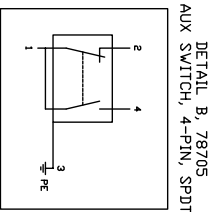
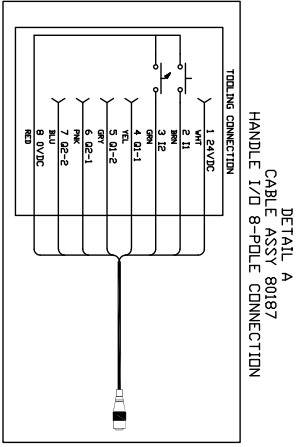
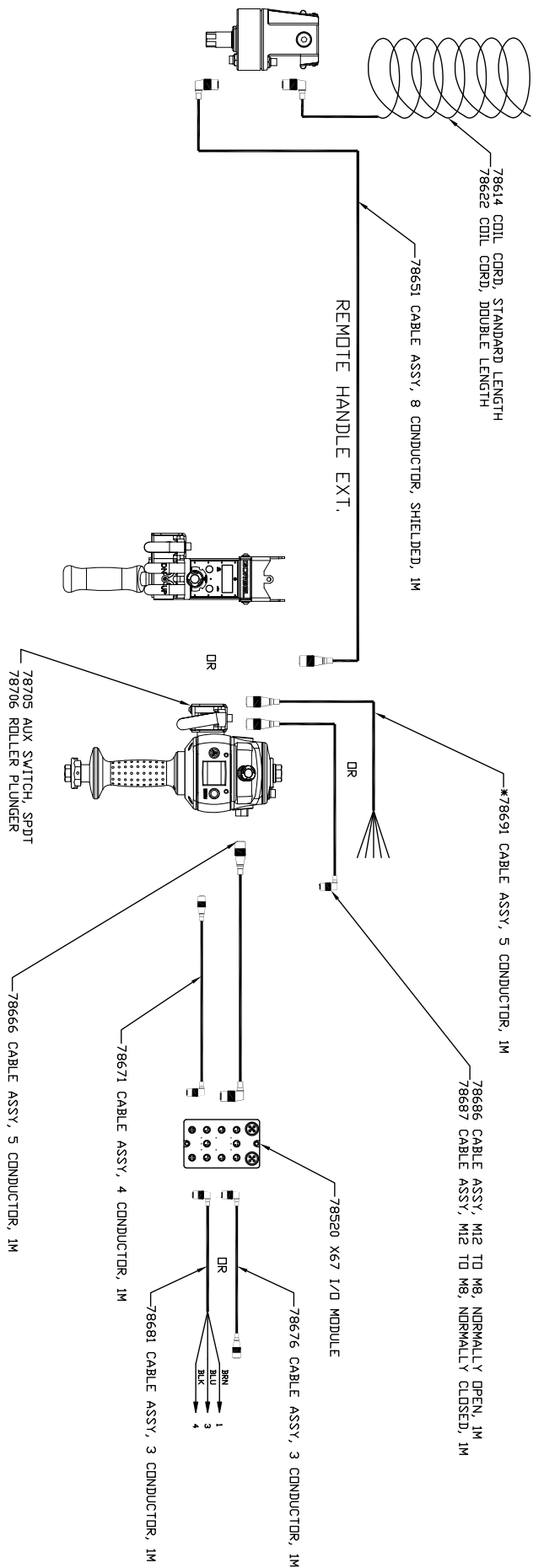

NOTE: Go to page 7-11 for a larger view of Detail A

ACTUATOR PCB GEN 2

| Fused Components | Fuse # | Fuse Size | Fuse P/N | MFG | MFG P/N |
|-------------------------------------|----------|--------------------|----------|----------|-----------|
| AC Power applied to system | F1 & F2 | 10 AMP Fast-Acting | 80548 | Schurter | 8020.5078 |
| AC Power applied to DC Power Supply | F9 & F10 | 2 AMP Fast-Acting | 80540 | Schurter | 8020.5071 |
| DC Power from DC Power Supply | F6 | 5 AMP Automotive | 80523 | Bussman | ATC-5 |

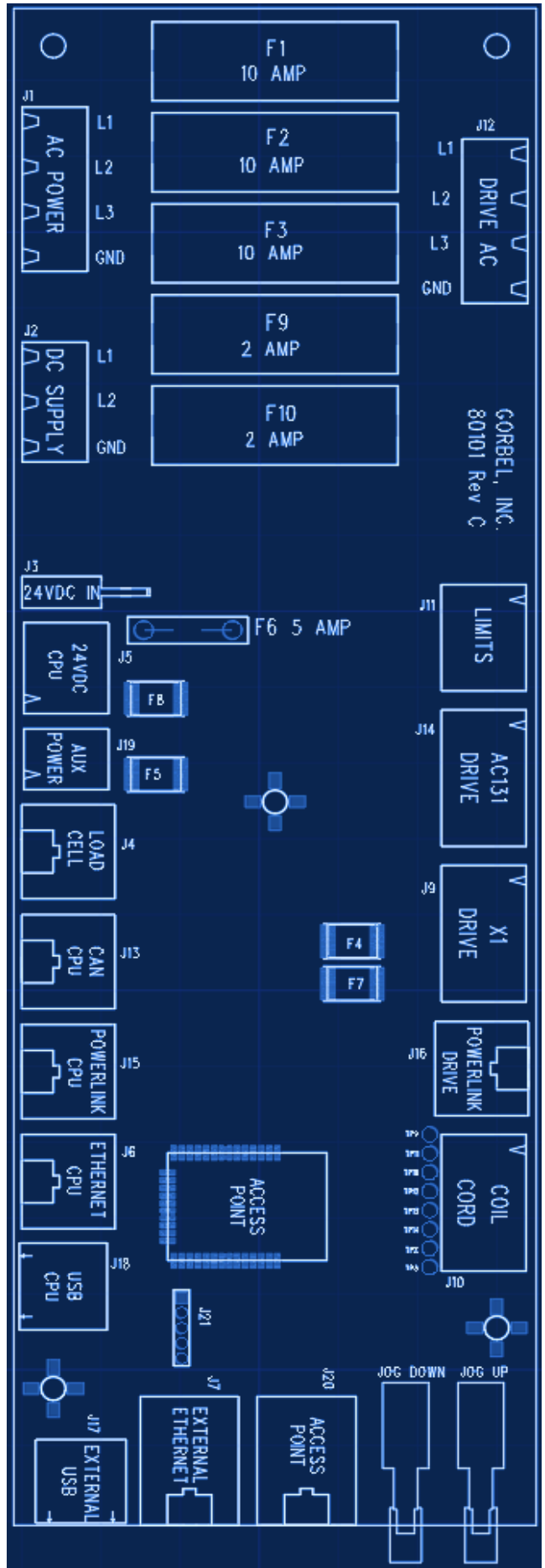

iQ2 Actuator CPU Input/Output Block

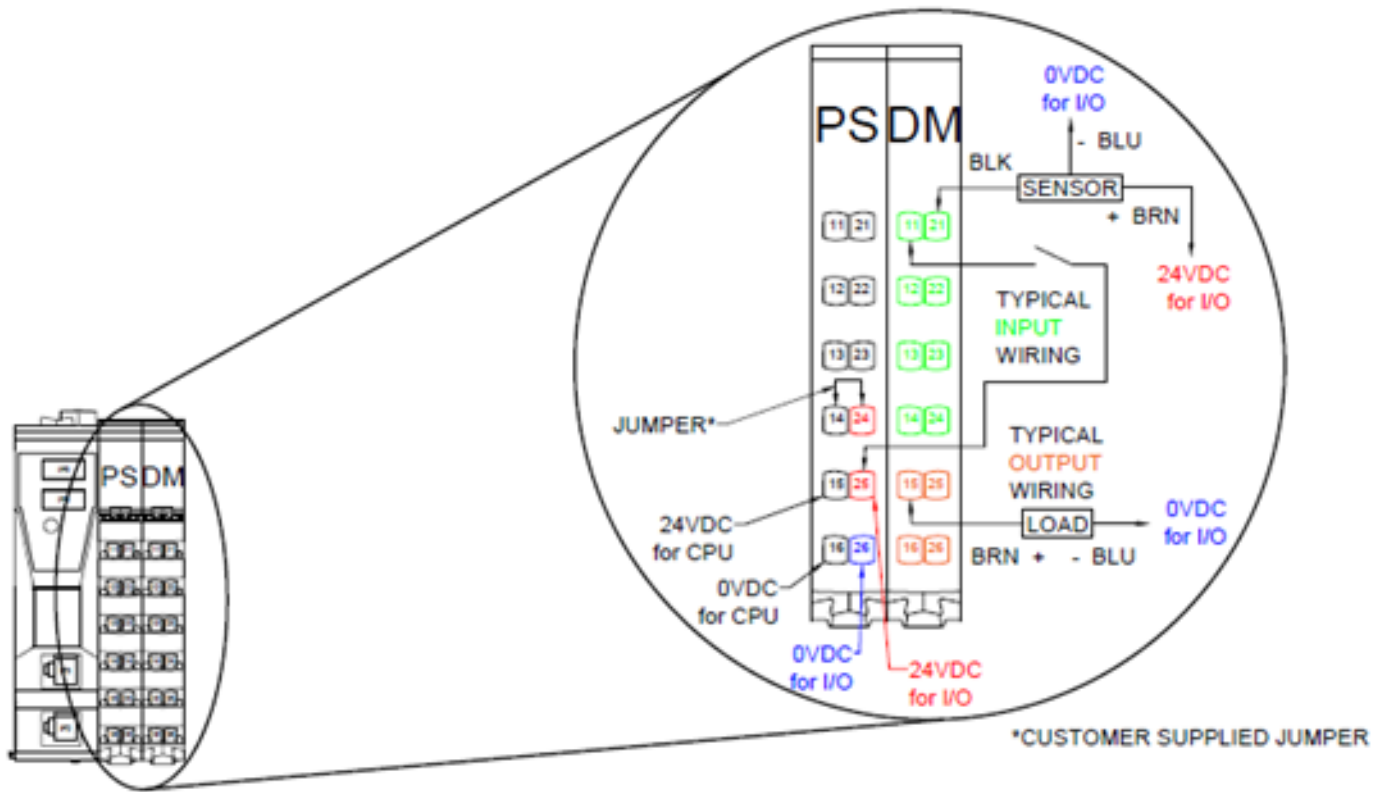

Note: The numbering sequence for the PS and DM modules is as follows as they apply to the Acuator I/O Configurators on the HMI screens. For example, 11 and 21 on the Actuator DM module equal 1 and 2 on the HMI screen. 12 and 22 on the DM module equal 3 and 4 on the HMI screen, etc. See illustrations below. The PS module has the same numerical layout as the DM module.

| DM Module # | HMI Screen # | |
|-------------|--------------|---------|
| 11 | 1 | INPUTS |
| 21 | 2 | |
| 12 | 3 | |
| 22 | 4 | |
| 13 | 5 | |
| 23 | 6 | |
| 14 | 7 | |
| 24 | 8 | |
| 15 | 1 | OUTPUTS |
| 25 | 2 | |
| 16 | 3 | |
| 26 | 4 | |

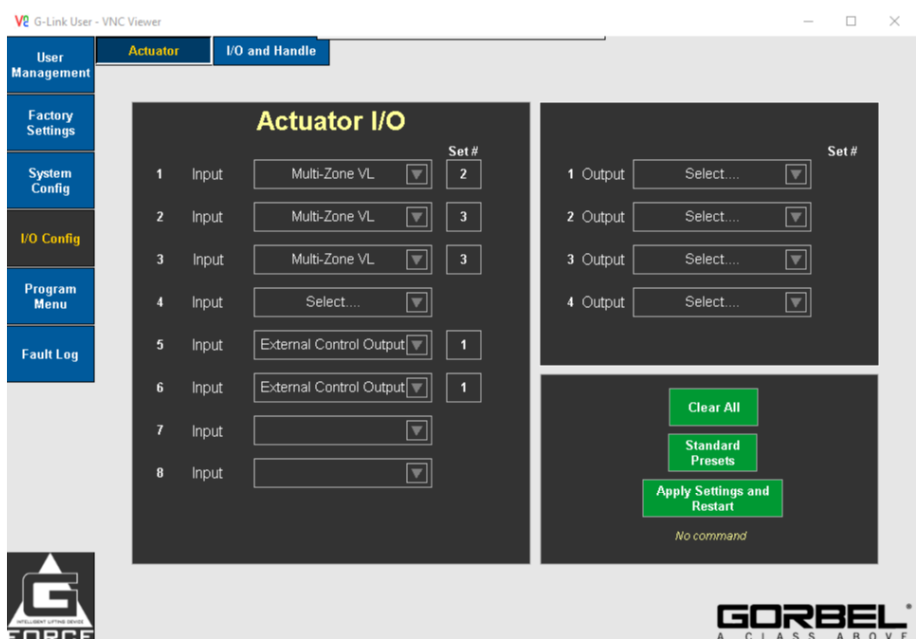

This page is intentionally left blank.

iQ2 Handle to external I/O block wiring (Slide and Force Sensing Handles)

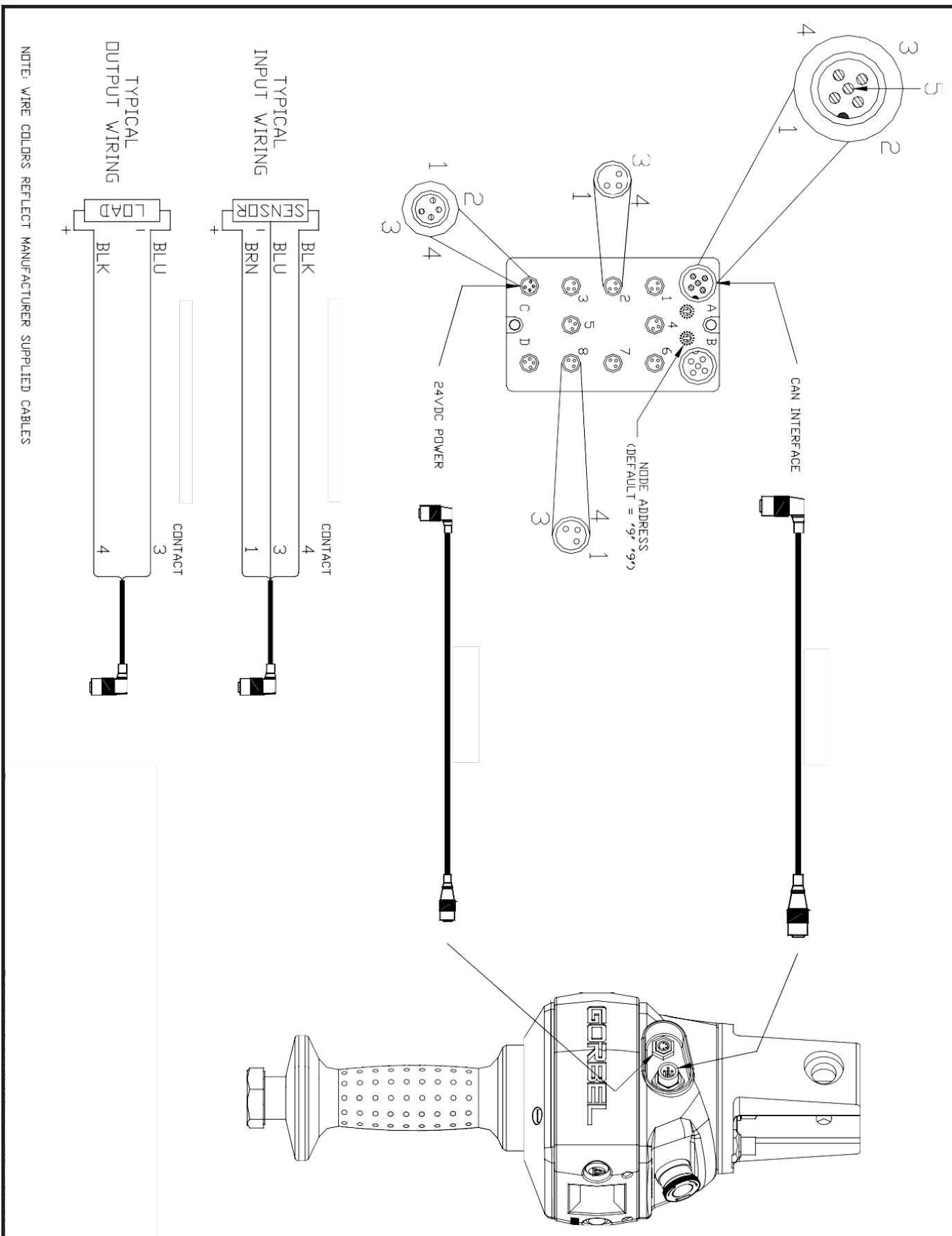

Diagram 9. Handle IO Detail, Slide Model.

iQ2 Handle to external I/O block wiring (Pendant Handle)

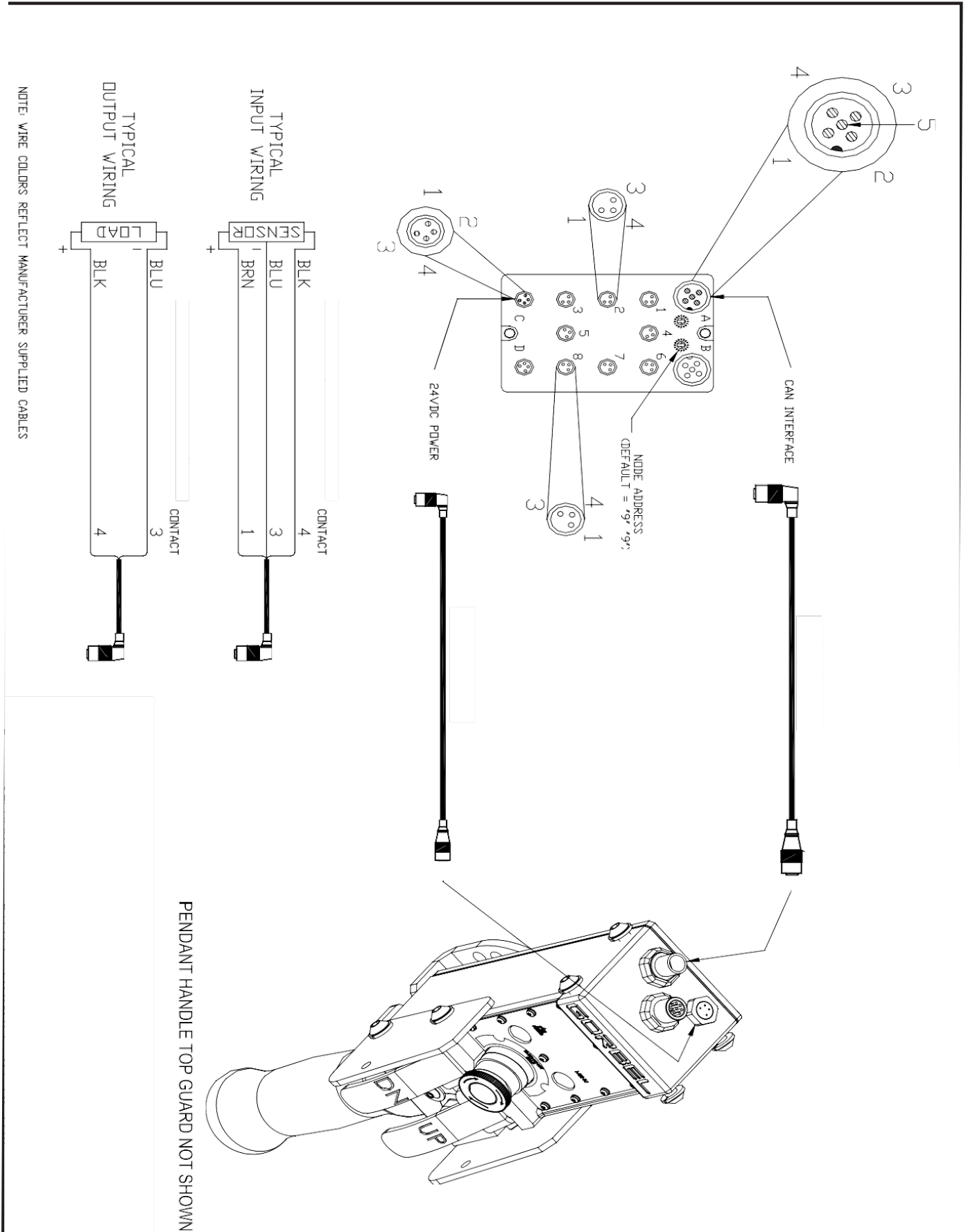
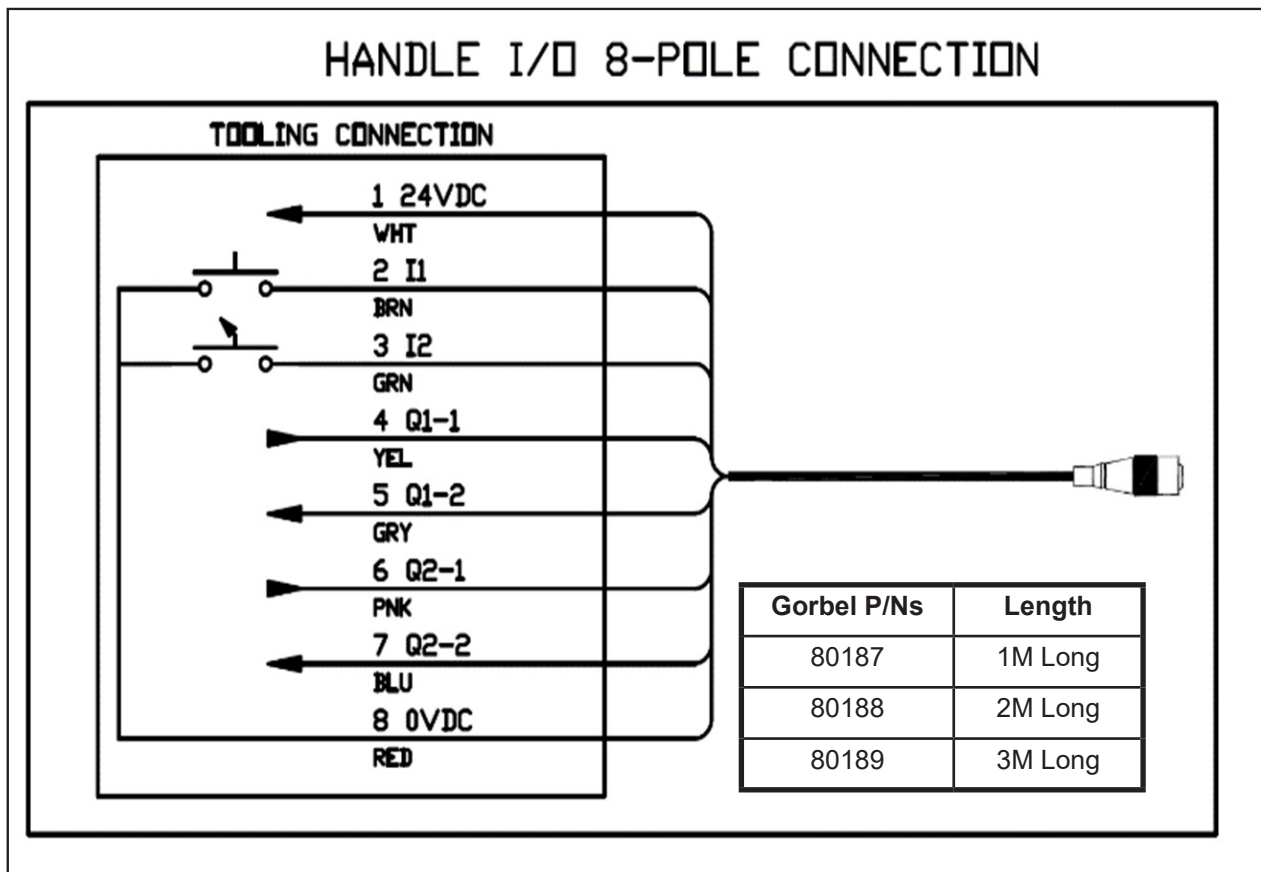
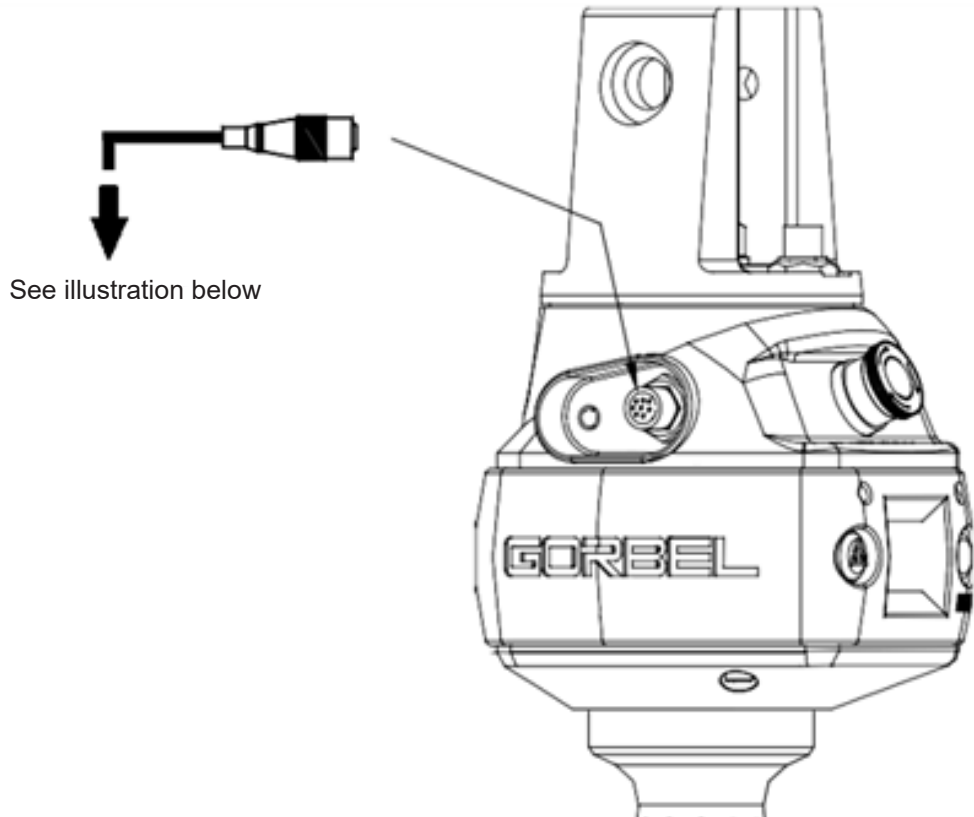

Diagram 10. Handle IO Detail, Pendant Model.

Q2 Handle Input/Output Wiring Harness Schematic



Chapter 8 - Adjustments

Upper and Lower Limit Switch Adjustment

Under normal conditions the Upper and Lower Limit Switches should not require adjustment in the field unless one were to fail and require replacement. These switches are set in the factory during assembly and final testing. There could be situations however that would require a slight adjustment.

The Limit Switch Assembly is located inside the actuator, on the side the wire rope exits the center casting. You must remove the Front Cover (short cover) to access this area. Refer to **diagram 1** below.

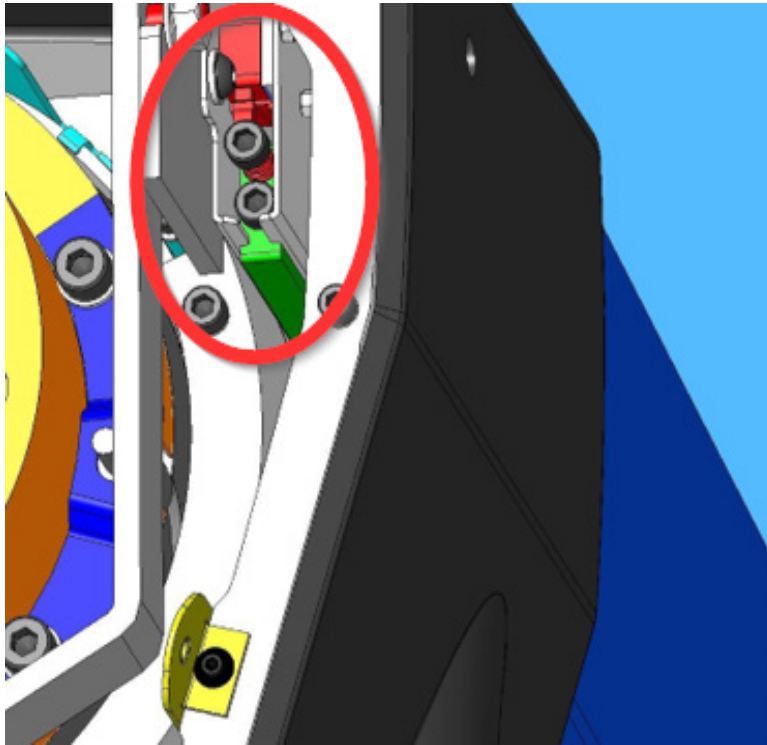

Diagram 1

Upper Limit Switch

The bottom allen head screw adjusts the upper limit. Use a 5mm allen wrench to perform the adjustment. Turning the screw clockwise raises the stop point of the wire rope. Counterclockwise lowers the stop point of the wire rope. A full turn is approximately 3 inches of wire rope travel. Refer to the side view in **diagram 2** below.

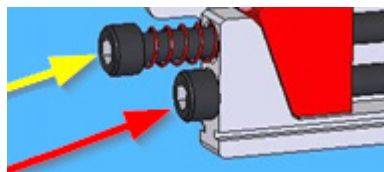

Diagram 2

Lower Limit Switch

The lower limit is a result of the wire rope replacement position. When this switch is actuated there should be approximately two full turns of wire rope left on the drum. There is no adjustment for this position. The switch provides protection for the hardware inside the actuator. Refer to **diagram 2** above.

Wire Rope Replacement Adjustment for the Lower Limit Switch

In order to determine whether this adjustment needs to be performed you must push the upper allen head screw in until it bottoms out against the body of the Limit Switch Assembly as illustrated in **diagram 4** below. While continuing to press the upper screw, press the Jog Down Button until the drum stops and the Wire Rope Retaining Plate is approximately at the 2-3 o'clock position as shown in **diagram 5** below. If the drum does not reach this position when it stops, turn the upper allen head screw 1/2 turn counterclockwise with a 5 mm allen wrench. Jog the wire rope up one full turn and repeat the process all over again.

Caution: If the wire rope retaining plate rotates past the 4 o'clock position, release the Jog Down Button **immediately** or internal damage may occur. Press the Jog Up Button until the drum makes one full rotation and adjust the Lower Limit Switch by turning the upper allen head screw one full turn clockwise.

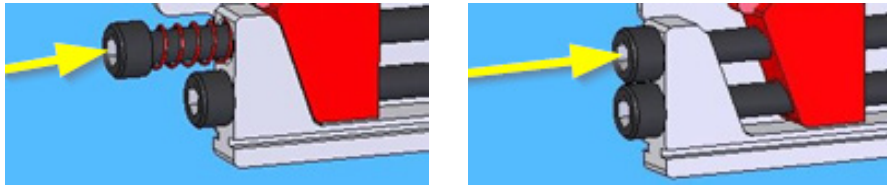

Diagram 3

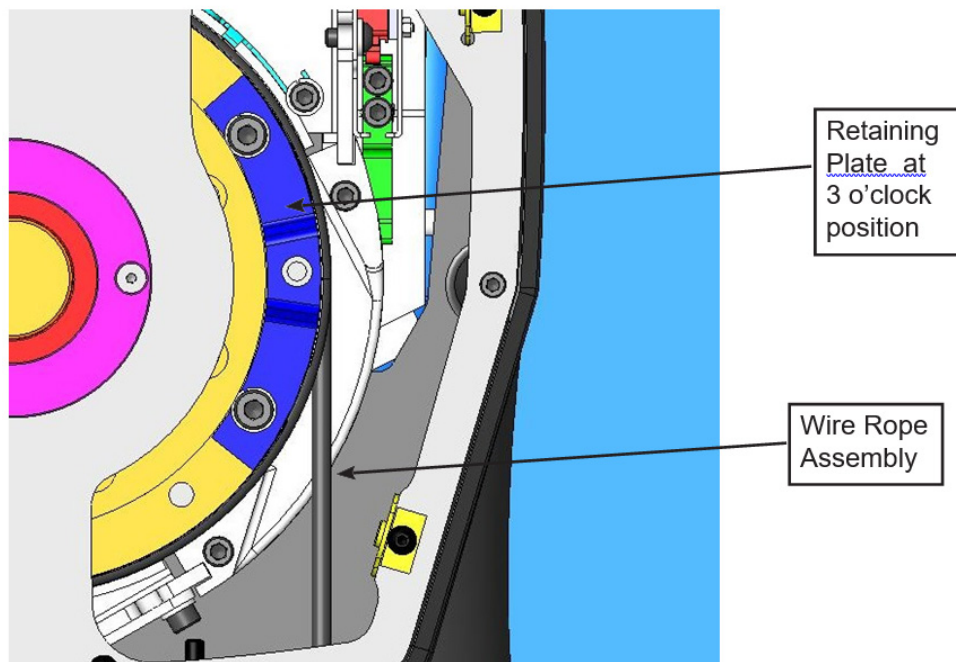

Diagram 4

Linear Transducer Adjustment

If there is motion (drift) in the system when the Operator Present Sensor is activated and the handle grip is not moved in either direction, the Linear Transducer will need to be adjusted. The adjustment can be monitored by reading the Analog Handle signal value on the Diagnostics page of the Visualization service menu.

1. Using a VNC Viewer navigate to **Program Menu > Service Menu > Diagnostics**. View the active Analog Signal under the Handle component of the page.
2. Do not move the slide portion of the handle at all during this process.
3. To decrease the number on the display, turn the LT Adjustment Screw counterclockwise. To increase the number on the display, turn the LT Adjustment Screw clockwise. Use a 2mm Allen wrench for the adjustment. Try increments of one revolution at a time.
4. Try to bring the value as close to zero as possible.

NOTE: the display may take a few moments to refresh after each adjustment.

2mm Allen Wrench

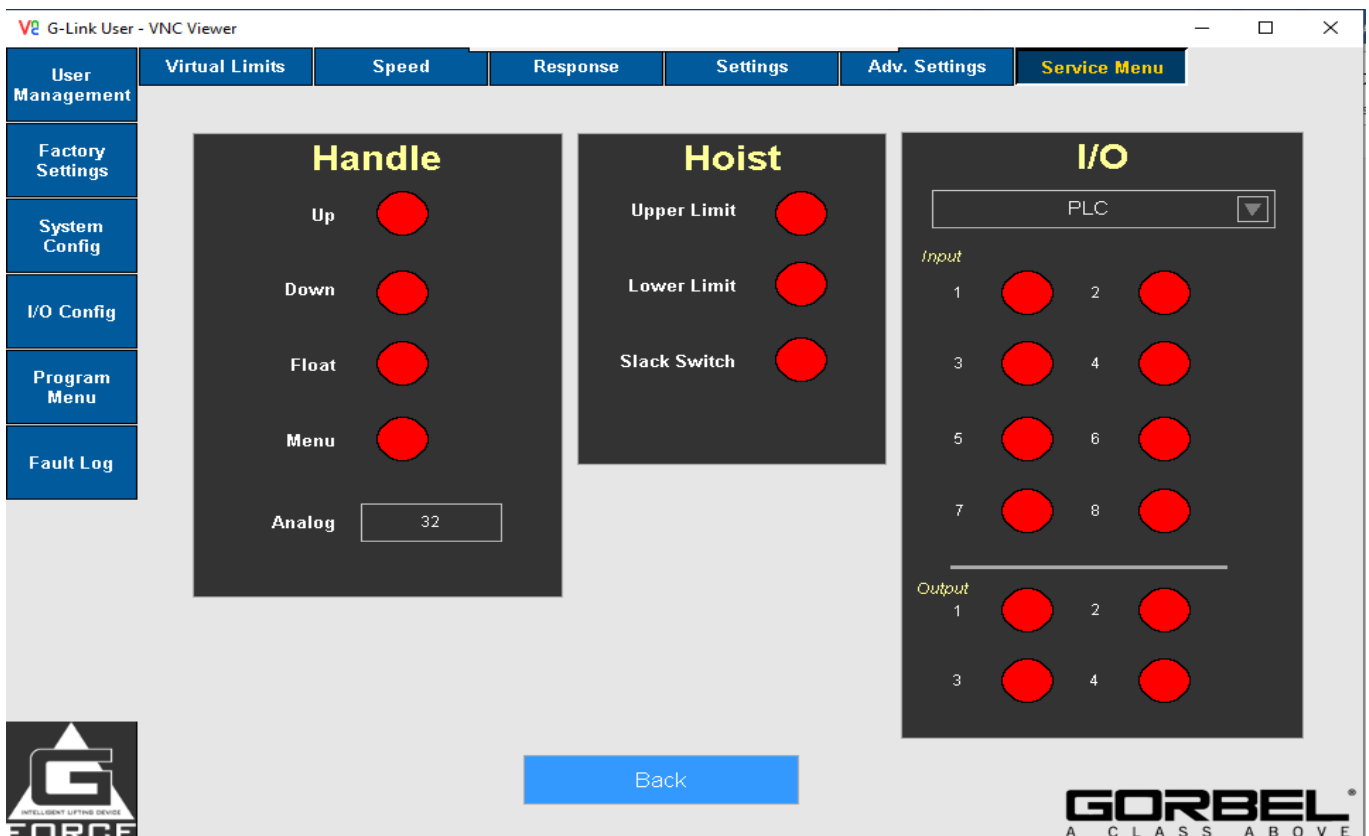

Slack Spring Adjustment

Slack spring adjustment is necessary if one or more of the following conditions apply:

- When wire rope continues to “pay out” from actuator when end effector (handle, hook, tooling) is being supported and down travel is commanded.
- When slack wire rope deflection exceeds 3 inches when end effector is supported.
- When tooling is added/removed to a G360™ assembly.
- When an air-line coil hose assembly is added between the end effector and actuator.
- When changing from a pendant handle to a slide handle or vice-versa occurs.
- **When chatter or erratic travel down operation occurs when using an unloaded G3601 or a weighted hook traveling downward from top of travel upper limit (spring is too tight).**

Unloaded G360™ equipped hoist may encounter this type of operation until tooling is added.

Slack Spring Adjustment Procedure:

1. Use an M3 hex wrench to remove all screws securing the blue rear cover (longer cover) to actuator. Place screws in cover and set aside.
2. Locate slack spring over the motor, next to casting (*diagram 5*). Spring is held in place by a motor bracket on one end and an eyebolt on the other end.
3. Using a 10mm open-end wrench, loosen the nut closest to the “eye” (inside nut) on eyebolt (*diagram 5*).

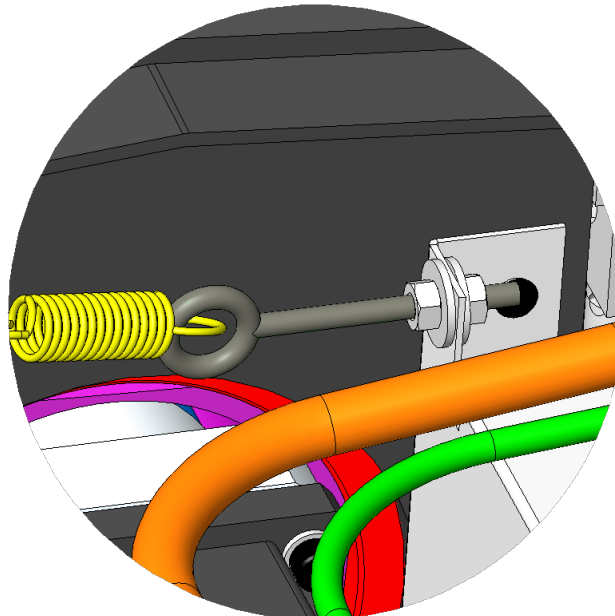

Diagram 5

4. If chatter or erratic operation of hoist while traveling down is encountered, the end effector or tooling on wire rope is not heavy enough to overcome the spring tension. Loosen the outside nut one half turn and test the hoist operation (full stroke up and down) between each half turn adjustment of eyebolt but until chattering is eliminated.
5. All other conditions will require the outside nut to be adjusted by turning clockwise, tightening to increase tension to the slack spring. Before tightening of this nut, be sure there is enough free travel of the eyebolt (inside nut remains loose).
6. Using the Jog Buttons travel downward resting end effector (handle, unloaded end tool, hook), supported upright on the floor. If rope continues to “pay out” from actuator beyond two seconds after reaching floor, release down Jog Button. Turn the outside nut clockwise one-half turn tightening it. Test again by traveling up removing handle or tooling from floor and travel down again resting on floor. Continue adjusting and testing this until rope travel stops within two seconds of effector resting (supported vertically) on floor.

7. Correct slack adjustment occurs when a deflection of the wire rope is 3-4 inches when in slack mode and rope travel stops (**diagram 6**). Tighten inside nut clockwise until “jammed” against sheet metal while keeping eye-bolt stationary.
8. If you are adjusting the slack spring on an Easy Arm, diagram 6 should be rotated 90 degrees clockwise to give you the correct orientation of the actuator. The end result of the adjustment should be the same as it is for a G-Force®.

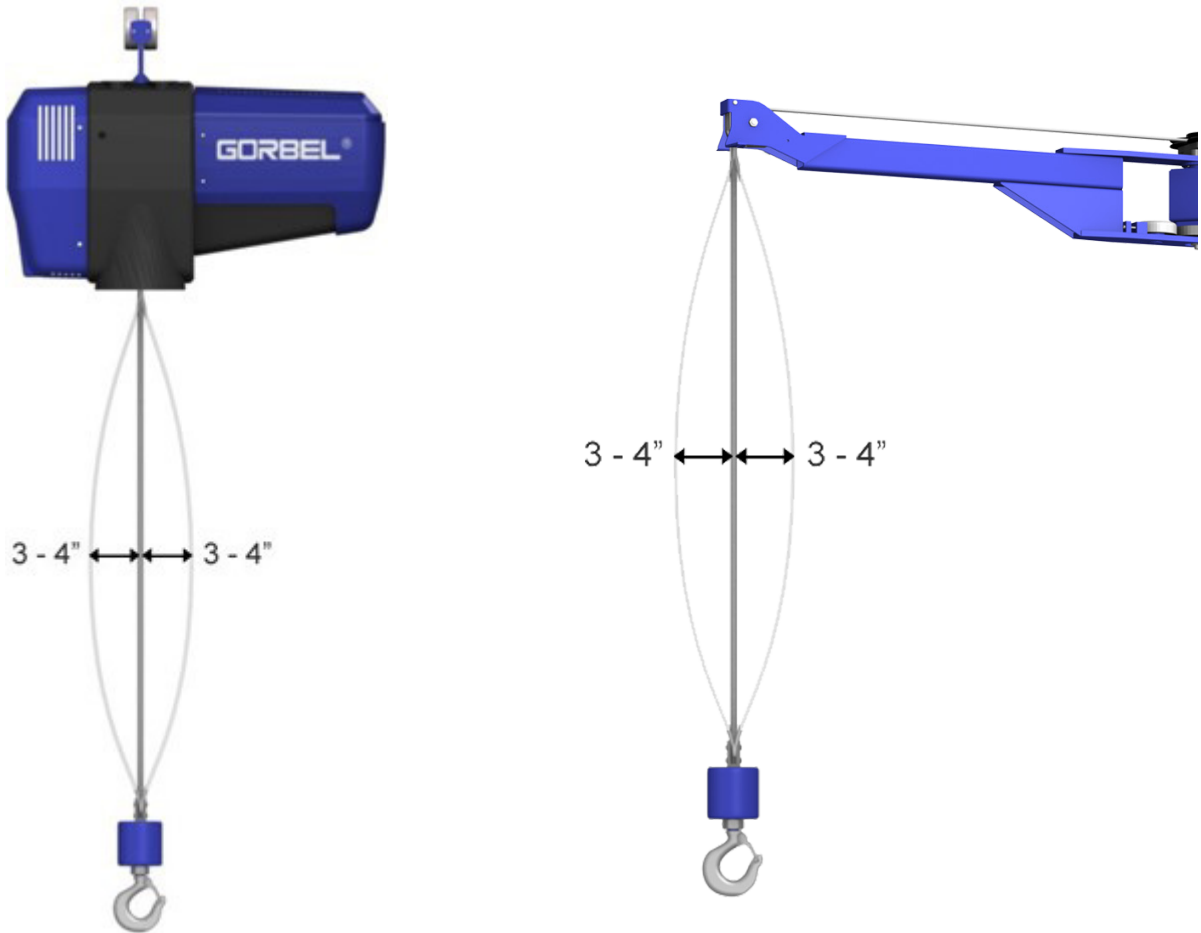

Diagram 6

NOTE: Easy Arm® Primary and Secondary Brake adjustments as well as Wire Rope replacement instructions for both G-Force and Easy Arm are contained in the G-Force and Easy Arm Installation & Operation Manuals.

Chapter 9 - Parts & Assembly

This chapter provides the Gorbel® part numbers for all capacity G-Force® Q2 and iQ2 models as well as the removal and replacement instructions for most of the components inside the actuators and control handles.

In most cases the Gorbel® part numbers for all three capacity G-Forces are the same. Where there are differences, separate pages and drawing notes are used to illustrate the differences. All Gorbel® part numbers are shown in parentheses and bold print.

Index

| | |
|----------------------------|------|
| Actuator | 9-2 |
| Sliding Handle | 9-31 |
| Pendant Handle | 9-40 |
| Force Sensing Handle | 9-53 |
| Coil Cords | 9-61 |
| G360™ | 9-65 |
| Easy Arm Components..... | 9-71 |

CAUTION!

Many of the removal/replacement procedures in this section require AC power to be removed from the actuator. You must disconnect the AC power plug from the AC source in order to do this or use a disconnect, if equipped with one. Using the e-stop button will not accomplish this because it does not interrupt AC power to the actuator.

Removal and Replacement Procedures

ACTUATOR

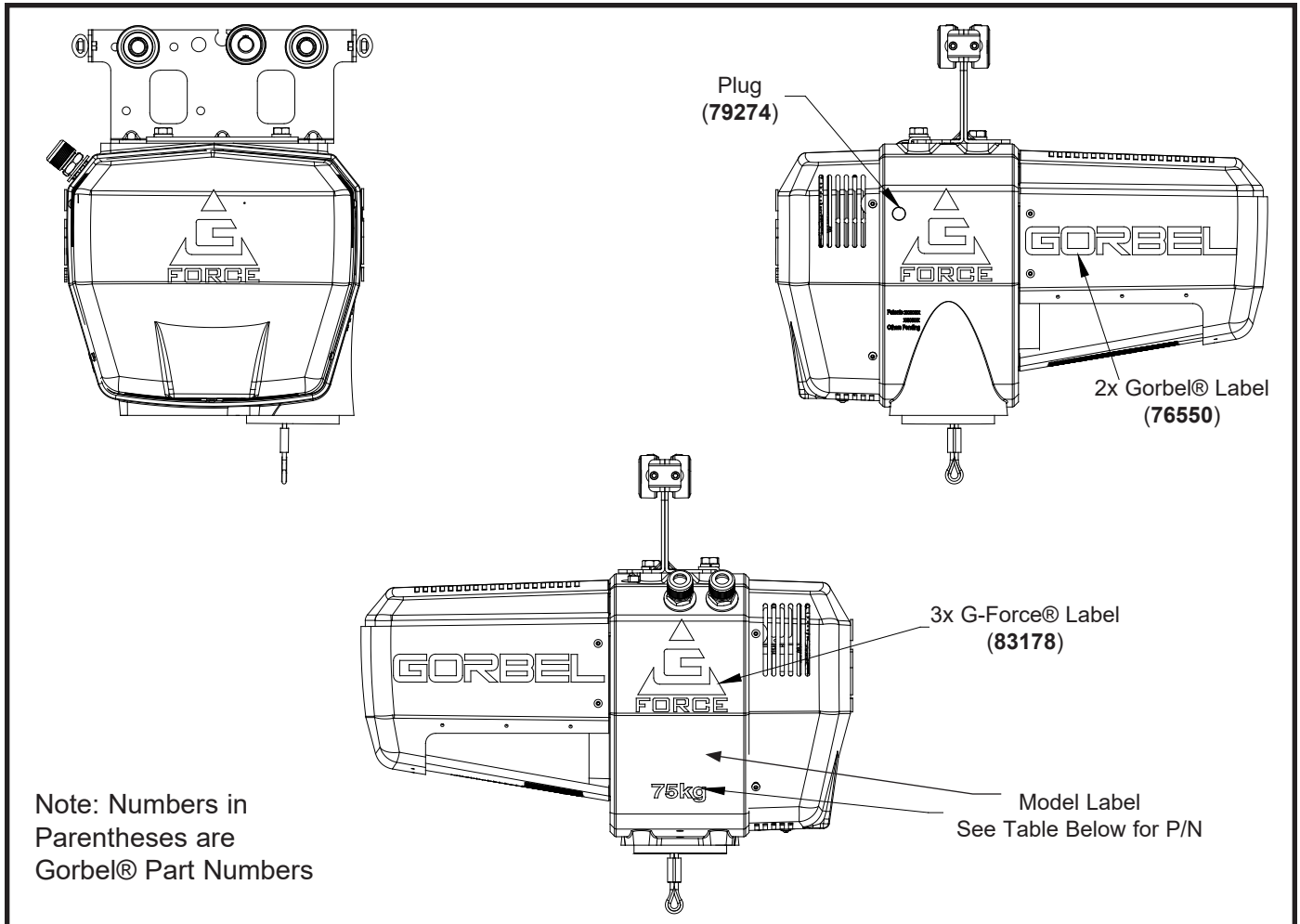

Note: Numbers in Parentheses are Gorbel® Part Numbers

G-Force Actuator Labels

| Model Labels | |
|--------------|-------|
| Q2 | 79260 |
| iQ2 | 79261 |

| Capacity | P/N |
|----------|-------|
| 165# | 35101 |
| 330# | 35103 |
| 660# | 35104 |
| 1320# | 35105 |
| 75kg | 35107 |
| 150kg | 35109 |
| 300kg | 35110 |
| 600kg | 35111 |

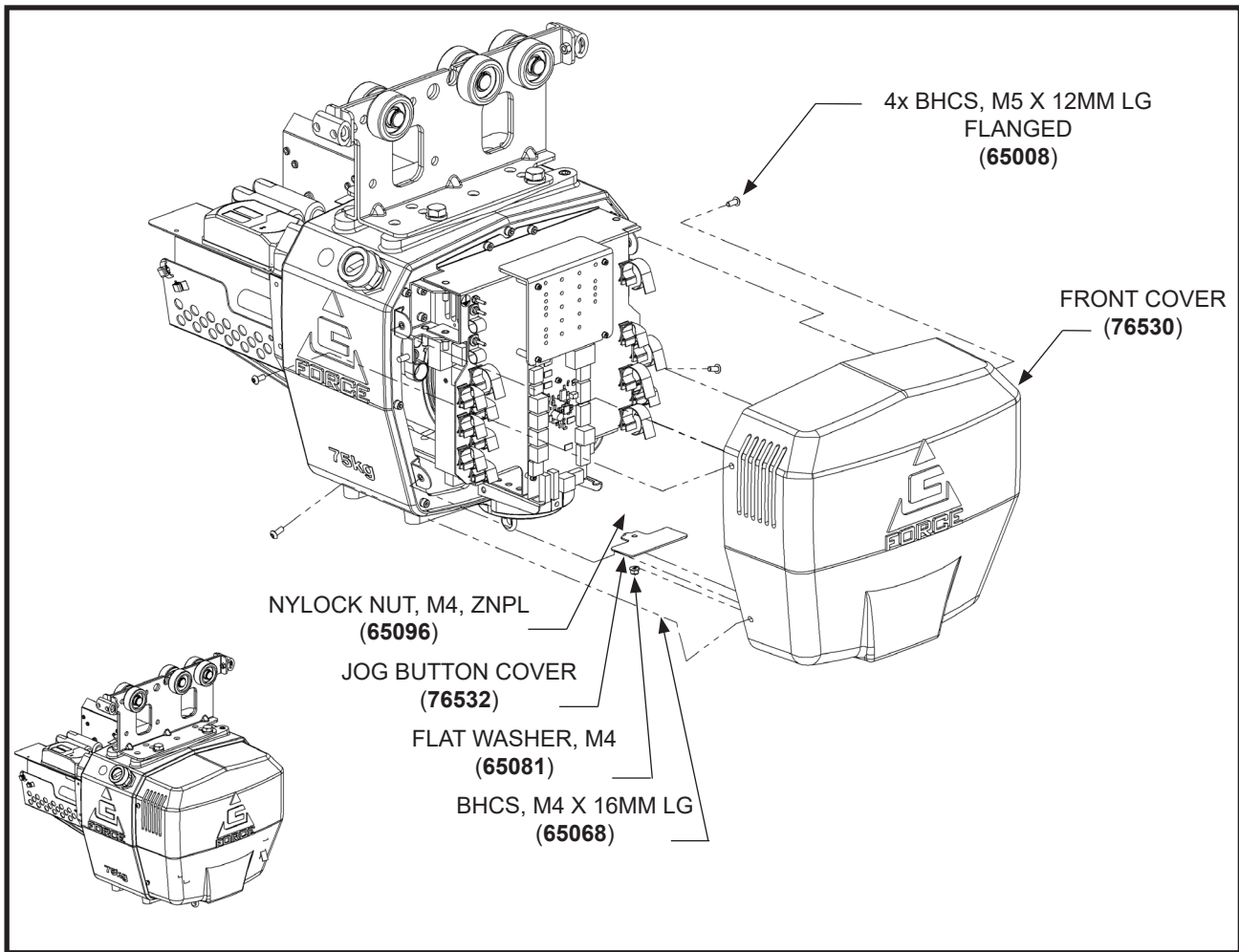
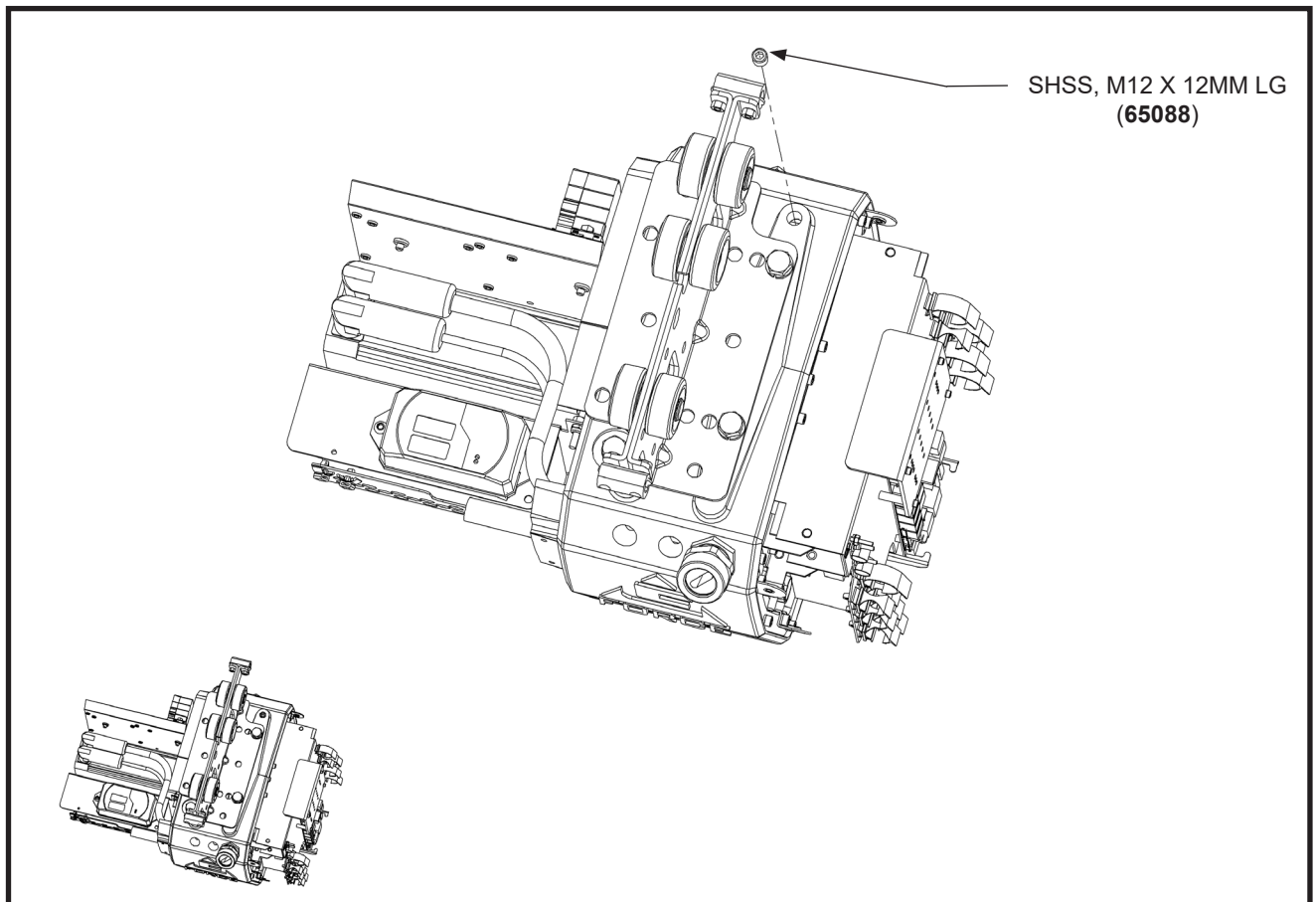
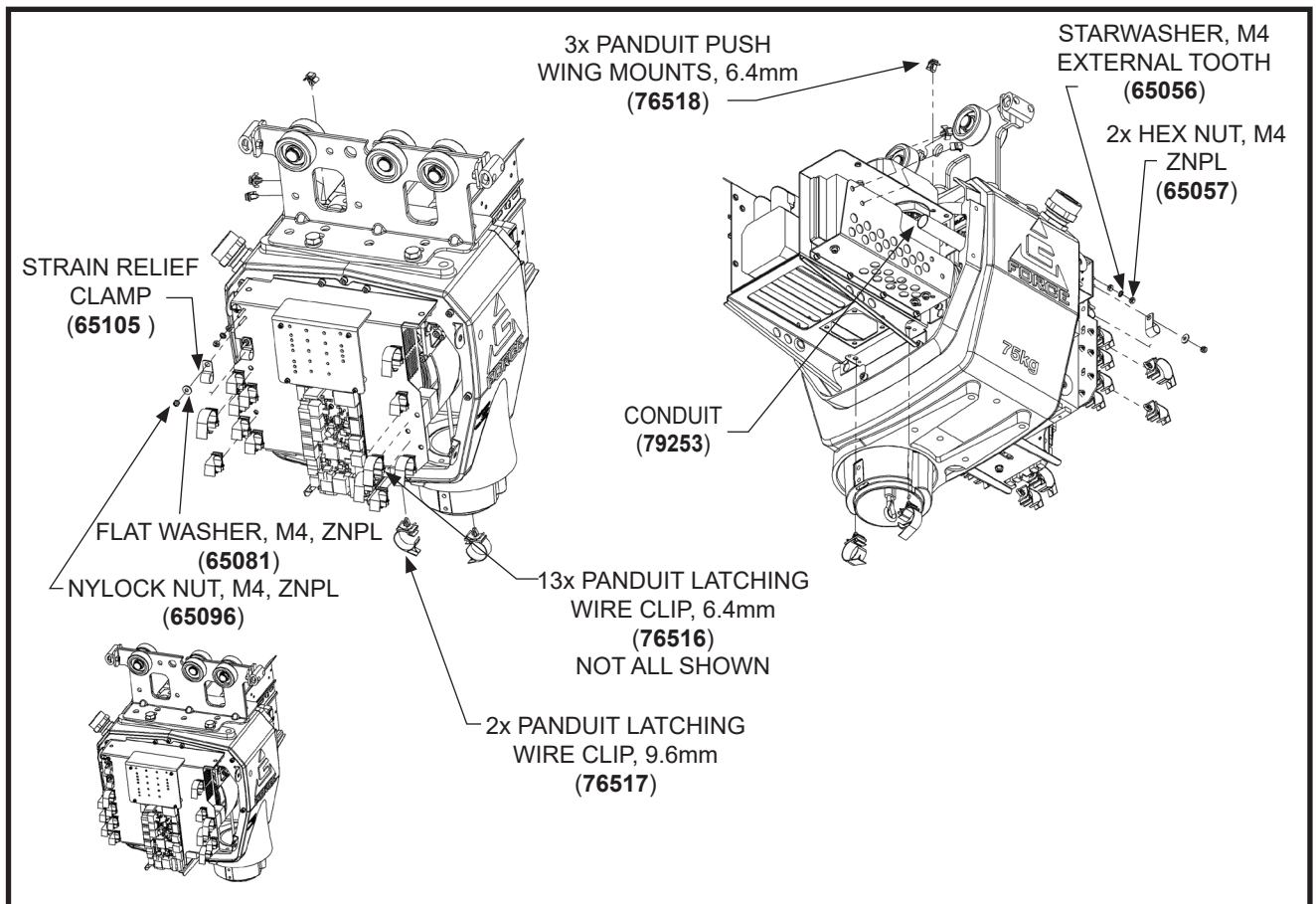

Diagram 1. Front Cover Removal and Replacement



Procedure 2A - Rear Cover Removal

1. Turn power off by disconnecting AC power to the system.
2. Remove (4) M5 button head cap screws (BHCS).
3. Carefully slide rear cover away from actuator casting.

Procedure 2B - Rear Cover Replacement

1. Carefully slide rear cover over ACOPOS assembly and align four holes with brackets attached to the actuator casting.
2. Install (4) M5 button head cap screws (BHCS).
3. Restore AC power to the system.

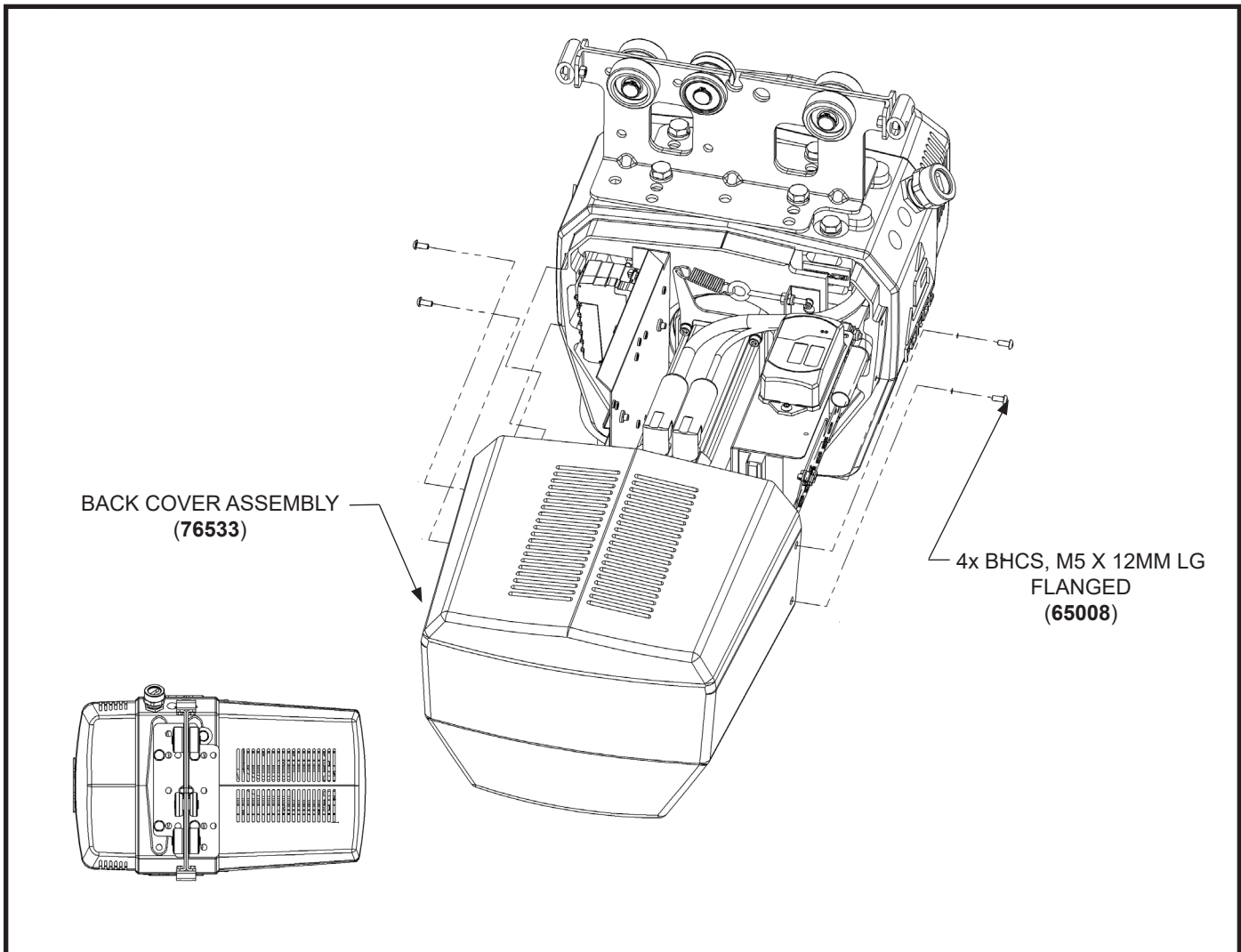

Diagram 2. *Rear Cover Removal and Replacement*

Procedure 3A - Electrical Shield Removal

1. Turn power off by disconnecting AC power to the system.
2. Remove front cover. Refer to Procedure 1A.
3. Remove (4) M3 socket head cap screws (SHCS) and M3 lockwashers
4. Remove electrical shield

Procedure 3B - Electrical Shield Replacement

1. Position the electrical shield on the actuator main PCB.
2. Install (4) M3 socket head cap screw (SHCS) and M3 lockwashers.
3. Tighten all hardware carefully to avoid damaging the electrical shield.
4. Install the front cover. Refer to Procedure 1B.
5. Restore AC power to the system.

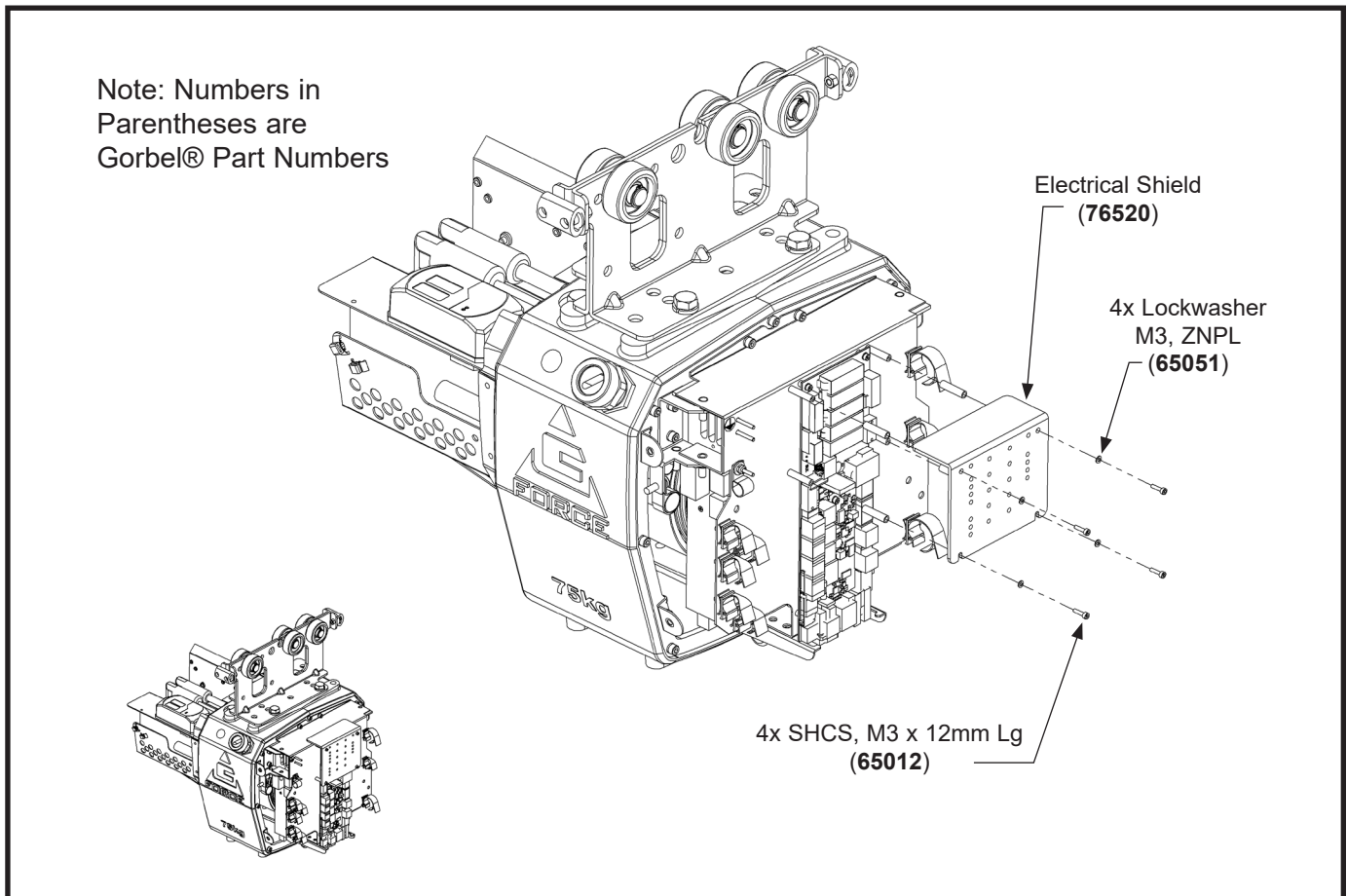

Diagram 3. *Electrical Shield Removal and Replacement*

Procedure 4A - Main PCB Removal

1. Turn off power by disconnecting AC power to the system.
2. Remove front cover. Refer to Procedure 1A.
3. Remove electrical shield. Refer to Procedure 3A.
4. Unplug cable assemblies from J1 through J20 on main PCB. Note the cable numbers for cable assemblies that connect to J4, J6, J13 and J15.
5. Remove (5) M3 socket head cap screws (SHCS) and M3 lockwashers.

Note: Use caution when handling the main PCB; to avoid damage handle only by edges of board.

Procedure 4B - Main PCB Replacement

1. Install (5) M3 socket head cap screws (SHCS) and M3 lockwashers.
2. Connect cable assemblies to J1 through J14 on the main PCB. Check the cable numbers for cable assemblies that connect to J4, J6, J13 and J15.
3. Install the electrical shield. Refer to Procedure 3B.
4. Install the front cover. Refer to Procedure 1B.
5. Restore AC power to the system.

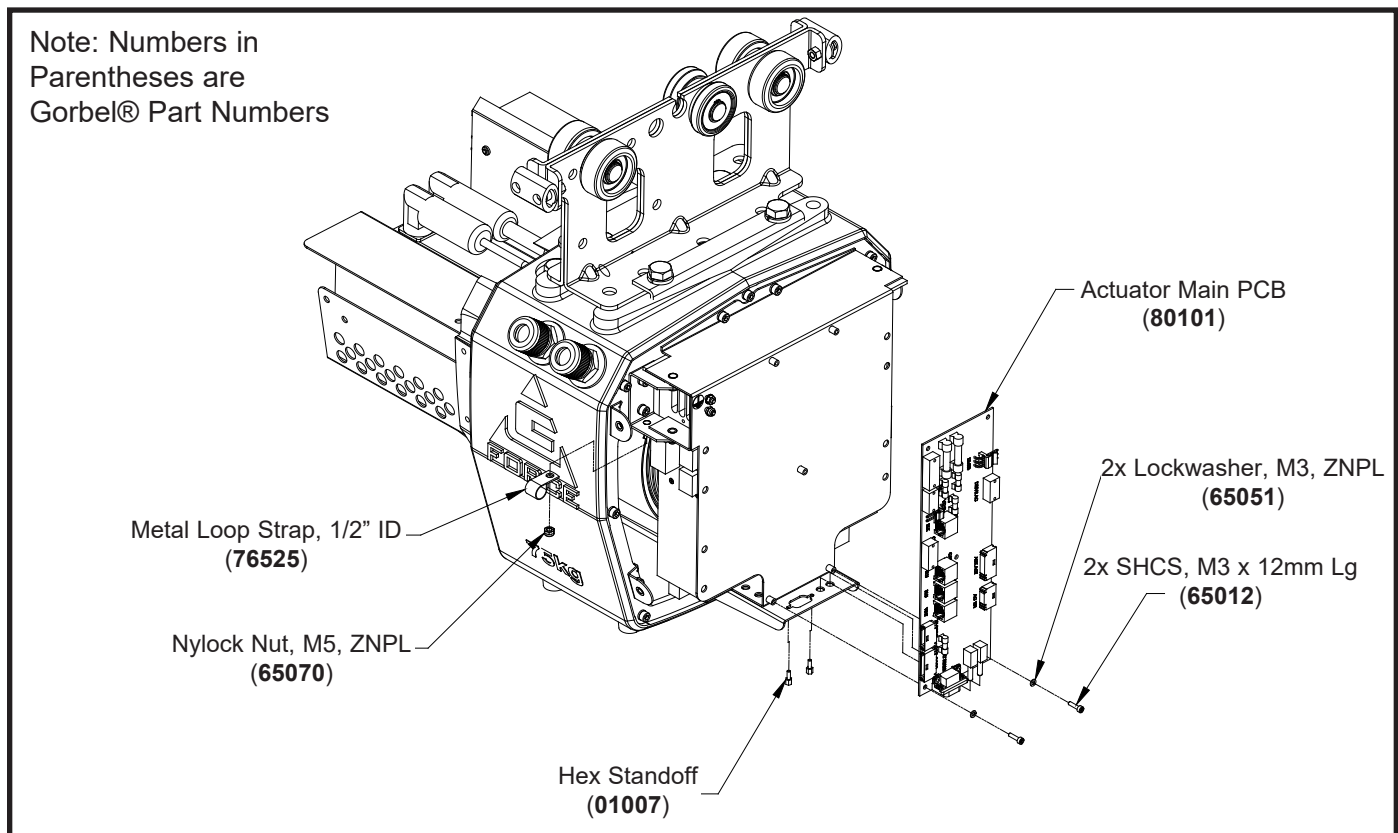

Diagram 4. Main PCB Removal and Replacement

Procedure 5A - Cooling Fan Removal

1. Turn power off by disconnecting AC power to the system.
2. Remove rear cover. Refer to Procedure 2A.
3. Unplug connector from cable assembly.
4. Remove (4) M4 button head cap screws, BHCS and M4 lockwashers and remove cooling fan.

Procedure 5B - Cooling Fan Replacement

1. Position cooling fan on underside of CPU / power supply mounting bracket.
2. Install (4) M4 button head cap screws, BHCS and M4 lockwashers.
3. Connect cable assembly.
4. Install rear cover. Refer to Procedure 2B.
5. Restore AC power to the system.

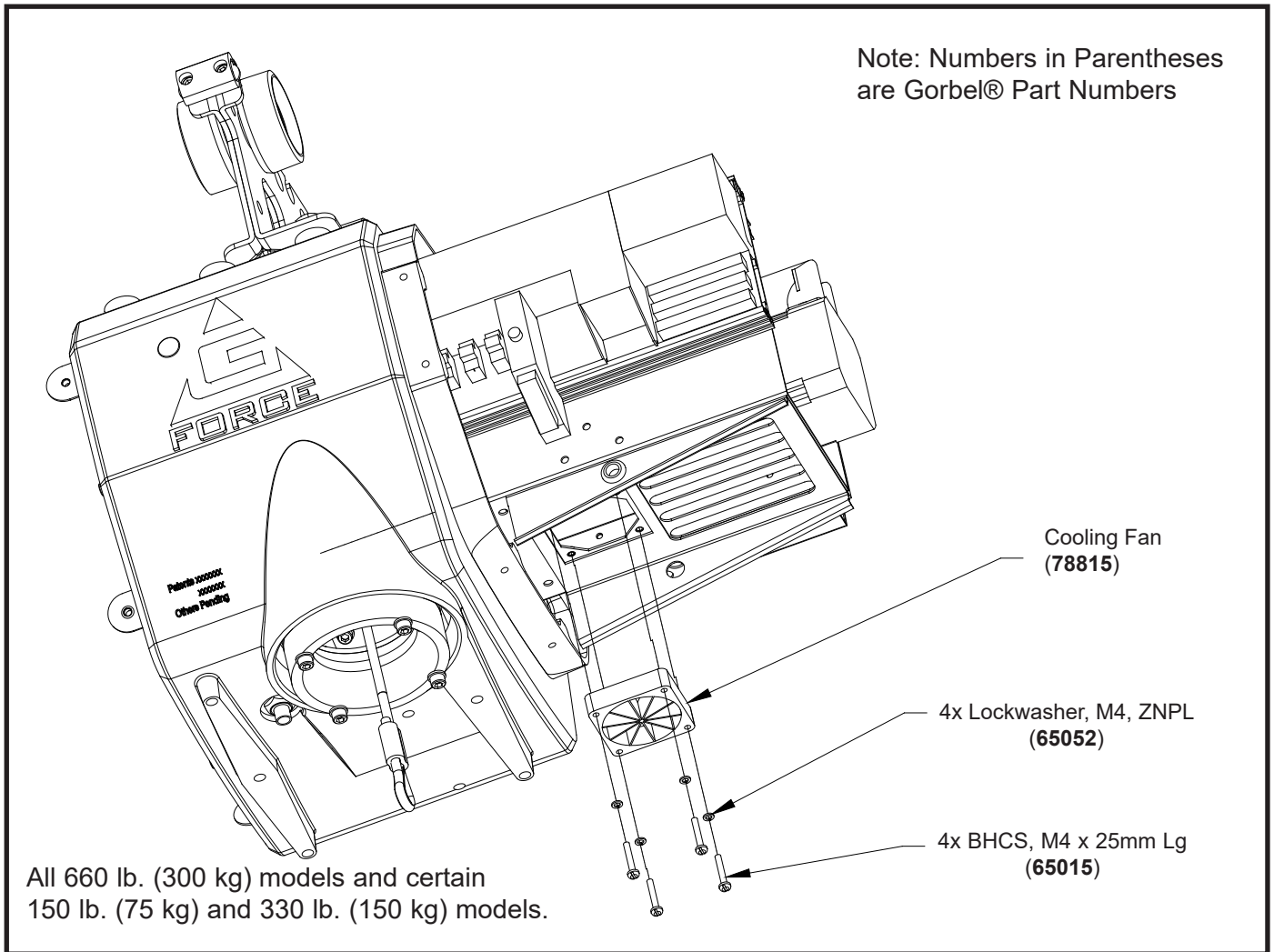
**Diagram 5. Cooling Fan Removal and Replacement.**

Procedure 6A - ACOPOS Support Bracket & ACOPOS Servo Drive Removal

1. Turn power off by disconnecting AC power to the system.
2. Remove front cover. Refer to Procedure 1A.
3. Remove electrical shield. Refer to Procedure 3A.
4. Remove main PCB. Refer to Procedure 4A.
5. Remove (2) M5 button head cap screws (BHCS) and M5 lockwashers from top portion of PCB / ACOPOS support bracket.
6. Remove (2) M5 button head cap screws (BHCS) and M5 lockwashers from lower portion of support bracket.
7. Disconnect all external cable assemblies from the ACOPOS drive, and release from latching wire clips. Note the cable numbers for cable assemblies that connect to J4, J6, J9, J13, J14 and J15.
8. Remove (2) M6 Nylock nuts from hinge pins.
9. Lift PCB / ACOPOS support bracket, with ACOPOS drive still attached, off hinge bracket.
10. Separate the ACOPOS servo drive from the PCB / ACOPOS support bracket assembly by removing the (2) M6 Nylock nuts from the underside of the upper portion of the PCB / ACOPOS support bracket assembly.

Procedure 6B - ACOPOS Support Bracket & ACOPOS Servo Drive Replacement

1. Attach ACOPOS servo drive to PCB / ACOPOS support bracket with the (2) M6 Nylock nuts.
2. Position PCB / ACOPOS support bracket with ACOPOS servo drive attached onto hinge bracket and install (2) M6 Nylock nuts.
3. Swing ACOPOS assembly into its normal operating position. Install all the cable assemblies to the ACOPOS servo drive, and secure into latching wire clips. Check the cable numbers for cable assemblies that connect to J4, J6, J9, J13, J14 and J15.
4. Install (2) M5 button head cap screws (BHCS) and M5 lockwashers into top portion of PCB / ACOPOS support bracket.
5. Install (2) M5 button head cap screws (BHCS) and M5 lockwashers into lower portion of PCB / ACOPOS support bracket.
6. Install main PCB. Refer to Procedure 4B.
7. Install electrical shield. Refer to Procedure 3B.
8. Install front cover. Refer to Procedure 1B.
9. Restore AC power to the system.

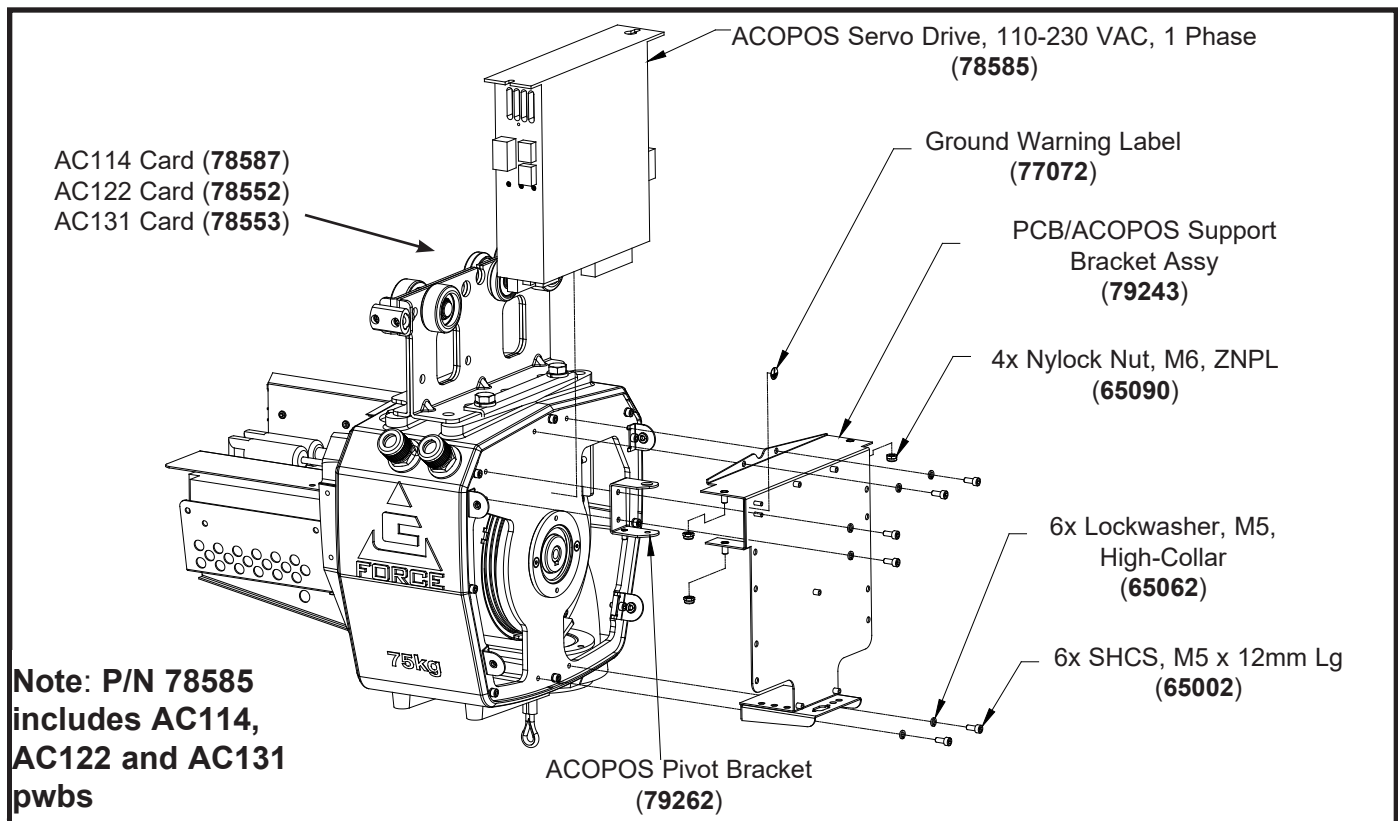

Diagram 6. ACOPOS and Support Bracket Removal and Replacement.

Procedure 7A - CPU Assembly Removal

1. Turn power off by disconnecting AC power to the system.
2. Remove rear cover. Refer to Procedure 2A.
3. Loosen End Block to the right of CPU and slide CPU about 3 inches to the right.
4. Disconnect all cable assemblies from the CPU. Note the cable numbers for cable assemblies that connect to IF2 & IF3.
5. If this is an IQ2 model it may be necessary to disconnect the terminal block for any I/O wiring from the I/O module.
6. Lift (2) Orange tabs releasing CPU from DIN rail and lift CPU off bracket.

Procedure 7B - CPU Assembly Replacement

1. Position CPU on DIN Rail close to the center casting.
2. Press (2) Orange tabs locking CPU onto DIN rail and gently tug CPU to ensure proper connection to bracket.
3. Connect all cable assemblies to CPU and any I/O wiring, if necessary. Check the cable numbers for cable assemblies that connect to IF2 & IF3.
4. Slide CPU & right end clamp terminal block back to the left until it contacts the left end clamp terminal block and retighten the right end clamp terminal block.
5. Reinstall rear cover. Refer to Procedure 2B.
6. Restore AC power to the system.

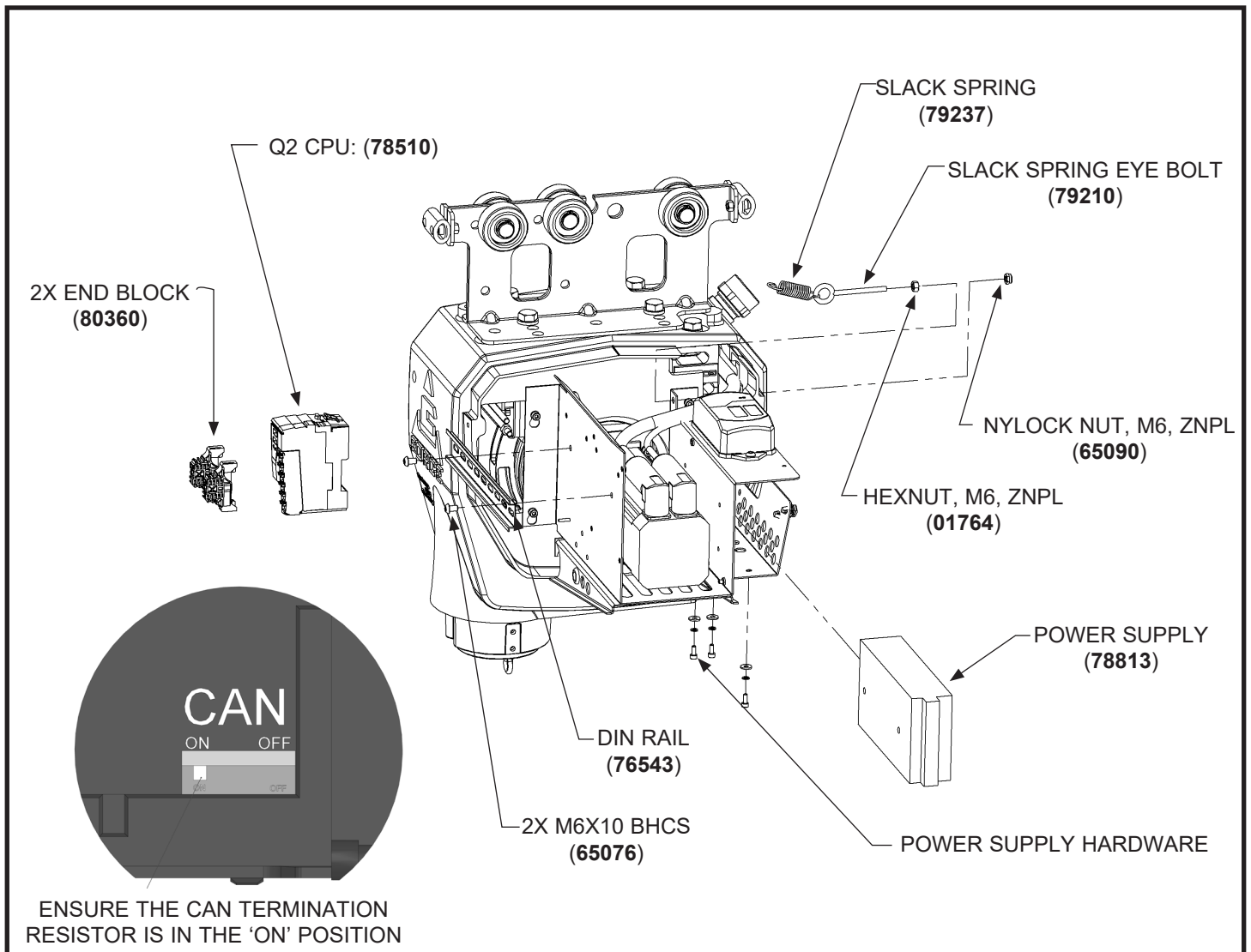
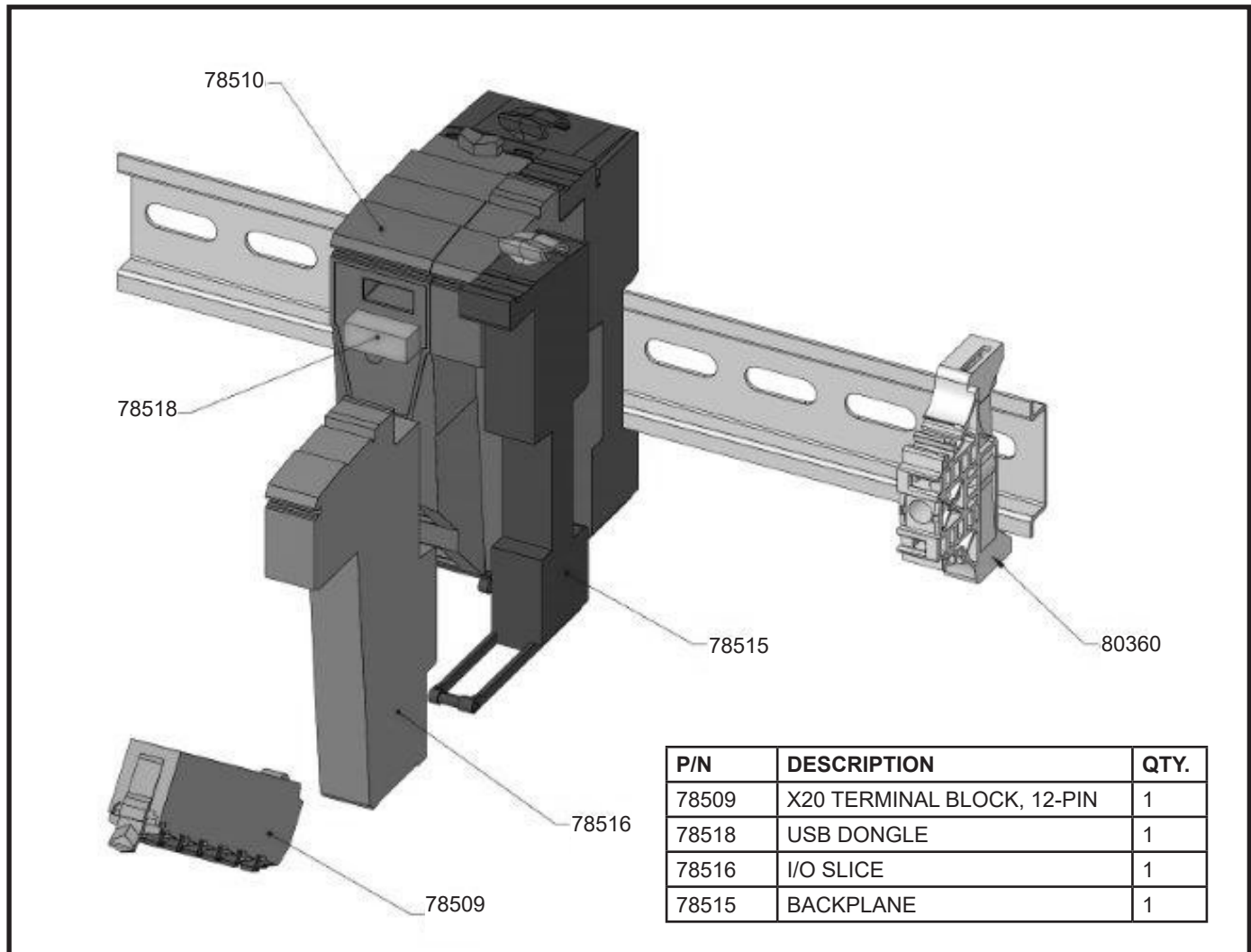

Diagram 7. CPU Removal & Replacement

iQ2 CPU



To add the CPU I/O Slice:

1. Loosen the End Block **80360**, and slide it to the right, then slide it off the Orange Right Side Cover.
2. Depress the tab on the face of the Terminal Block, **78509**, swinging it down to $\geq 90^\circ$ to remove from the CPU, **78510**.
3. Take the Backplane, **78515**, and lift the Orange Lever Tab on top until it clicks into the unlocked position. Then, align it with the slots in the CPU, **78510**, and *FIRMLY* press it against the CPU while sliding it toward the Din Rail.
4. Take the I/O Slice, **78516**, and slide it into the Backplane, **78515**, ensuring that the I/O Slice is flush with the face of the CPU, **78510**.
5. **MAKE SURE THERE IS NO GAP BETWEEN THE I/O SLICE, 78516, AND THE CPU, 78510.** If there is a gap, start over at step 1.
6. Latch the Backplane, **78515**, onto the Din Rail by lowering the Orange Lever Tab until it clicks into the locked position.
7. Replace the Terminal Block, **78509**, onto the CPU by aligning the Terminal Block's hook with the pin at the base of the CPU, **78510**, creating a hinge. Then, swing it upward until it clicks into place. Repeat this for the new I/O Terminal Block, **78509**.
8. Slide on the Orange Right Side Cover and resecure the End Block, **80360**, next to the CPU.
9. Insert USB Dongle, **78518**, into the available USB port on the CPU, **78510**.

Procedure 9A - CPU / Power Supply Mounting Bracket Removal

1. Turn power off by disconnecting AC power to the system.
2. Remove rear cover. Refer to Procedure 2A.
3. Remove CPU assembly. Refer to Procedure 8A.
4. Remove power supply. Refer to Procedure 9A.
5. Disconnect slack spring.
6. Free any wiring harnesses required.
7. Remove (6) M5 socket head cap screws, SHCS and (6) M5 lockwashers.

Procedure 9B - CPU / Power Supply Mounting Bracket Replacement

1. Position CPU / power supply mounting bracket against actuator casting.
2. Install (6) M5 socket head cap screws, SHCS and (6) M5 lockwashers.
3. Reconnect slack spring.
4. Reinstall power supply. Refer to Procedure 9B.
5. Reinstall CPU assembly. Refer to Procedure 8B.
6. Reposition any wiring harnesses as required.
7. Reinstall rear cover. Refer to Procedure 2B.
8. Restore AC power to the system.

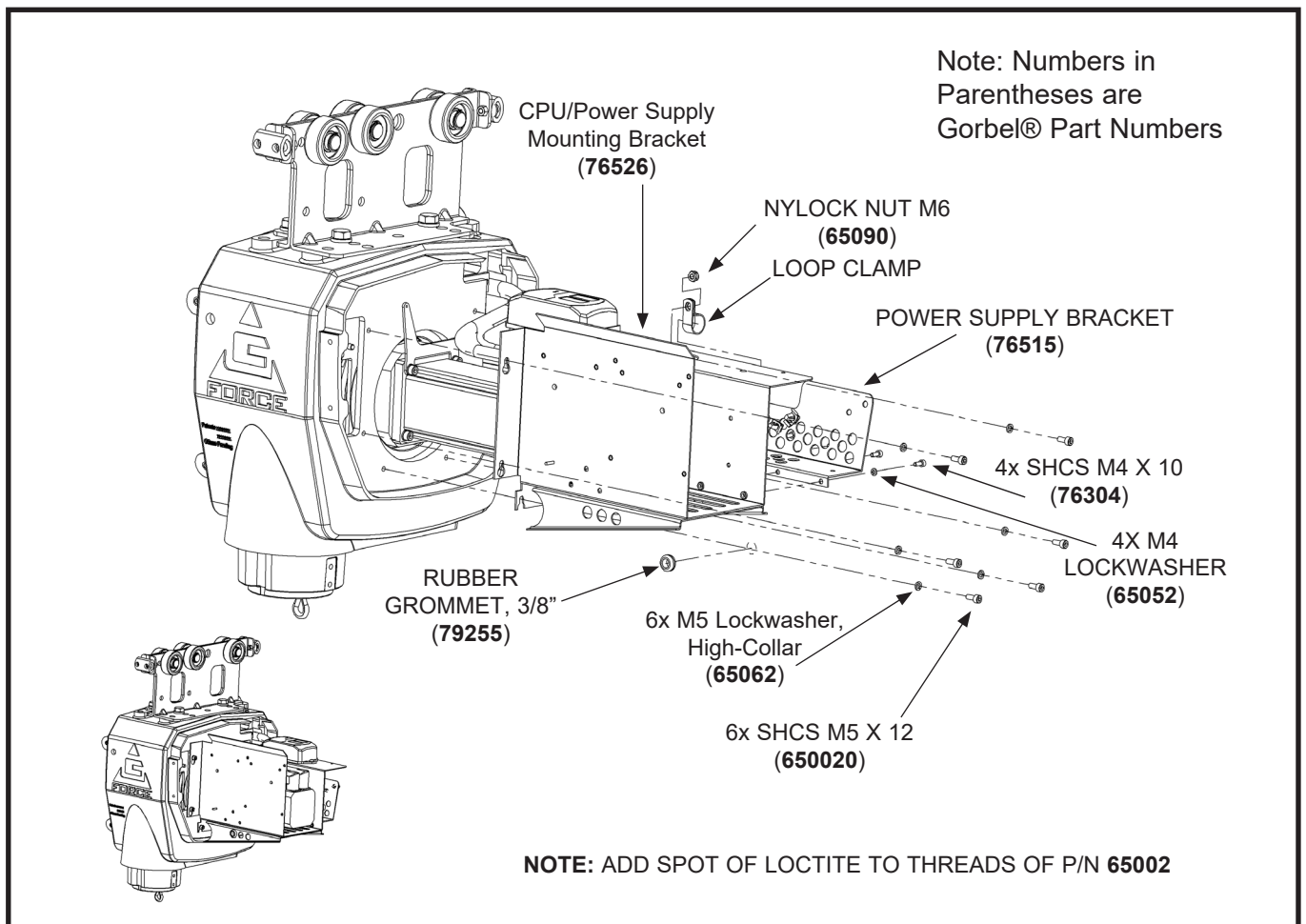

Diagram 9. CPU/Power Supply Mounting Bracket Removal and Replacement.

Procedure 10A - Motor Set Removal

1. Turn power off by disconnecting AC power to the system.
2. Remove rear cover. Refer to Procedure 2A.
3. Remove resolver and motor power cables from motor set.
4. Remove (4) M6 socket head cap screws (SHCS) and M6 lockwashers from motor set.
5. Carefully pry/wiggle motor set away from gearbox assembly.

Procedure 10B. Motor Set Replacement

1. Align key on motor set shaft with gearbox assembly and push motor set into gearbox assembly with mounting holes properly aligned.
2. Position slack spring bracket on left side of motor set and secure motor set with (4) M6 socket head cap screws (SHCS) and M6 lockwashers. Note: Do not tighten hardware completely until all (4) screws have been installed and are hand tight.
3. Connect resolver and motor power cables to motor set.
4. Reinstall rear cover. Refer to Procedure 2B.
5. Restore AC power to the system.

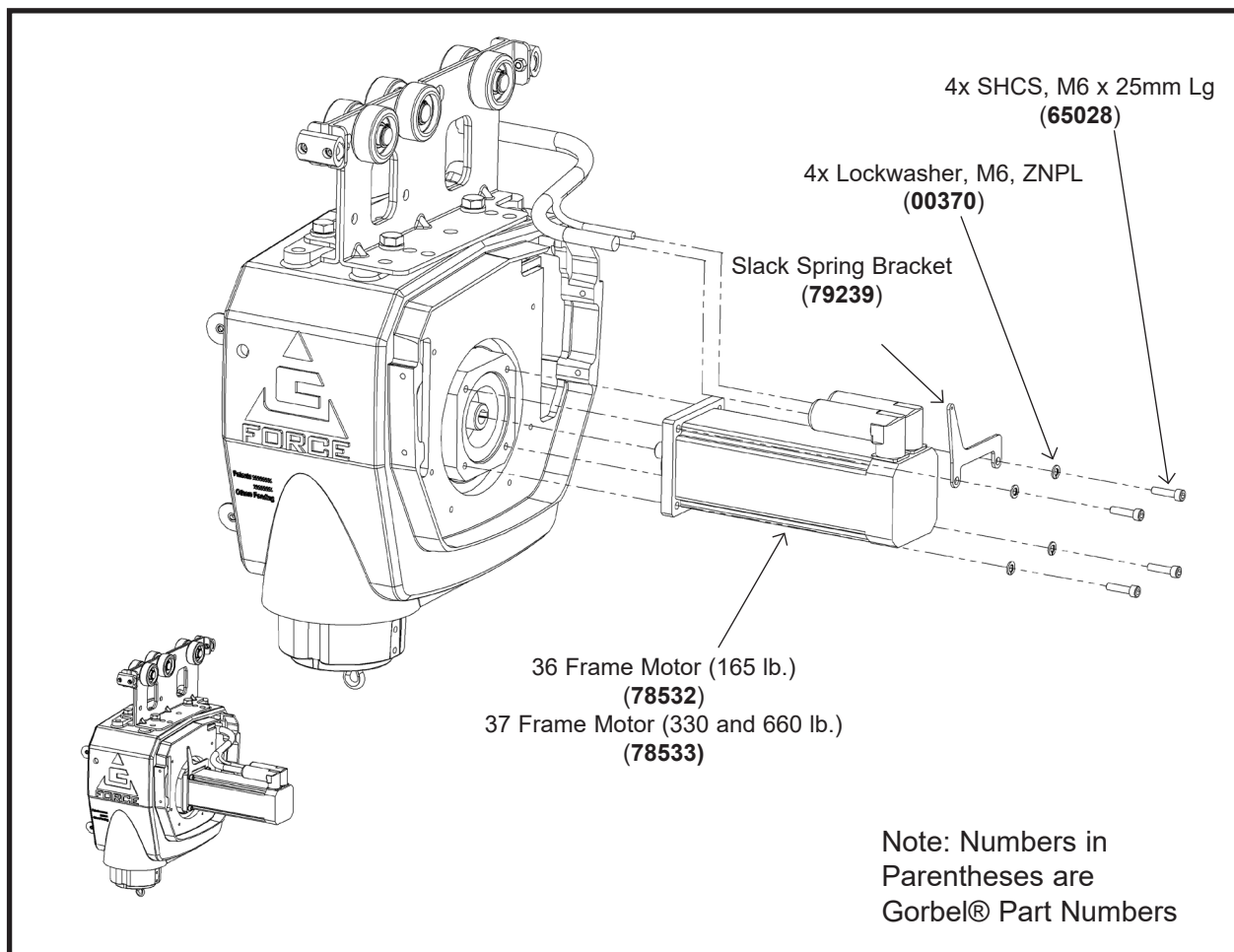
Diagram 10. Motor Set Removal & Replacement

Procedure 11A - End Support Frame Removal

1. Turn power off by disconnecting AC power to the system.
2. Remove front cover. Refer to Procedure 1A.
3. Remove ACOPOS support bracket with electrical shield, main PCB and ACOPOS servo drive still attached. Disconnect all cable assemblies from the main PCB and ACOPOS drive as required. Refer to Procedure 5A.
4. Remove (7) M5 socket head cap screws (SHCS) and M5 lockwashers from end support frame.

Procedure 11B - End Support Frame Replacement

1. Align the end support frame with the holes in the actuator casting and install (7) M5 socket head cap screws (SHCS) and M5 lockwashers.
2. Install the ACOPOS support bracket with electrical shield, main PCB and ACOPOS servo drive. Connect all cable assemblies to the main PCB and ACOPOS drive. Refer to Procedure 5B.
3. Install the front cover. Refer to Procedure 1B.
4. Restore AC power to the system.

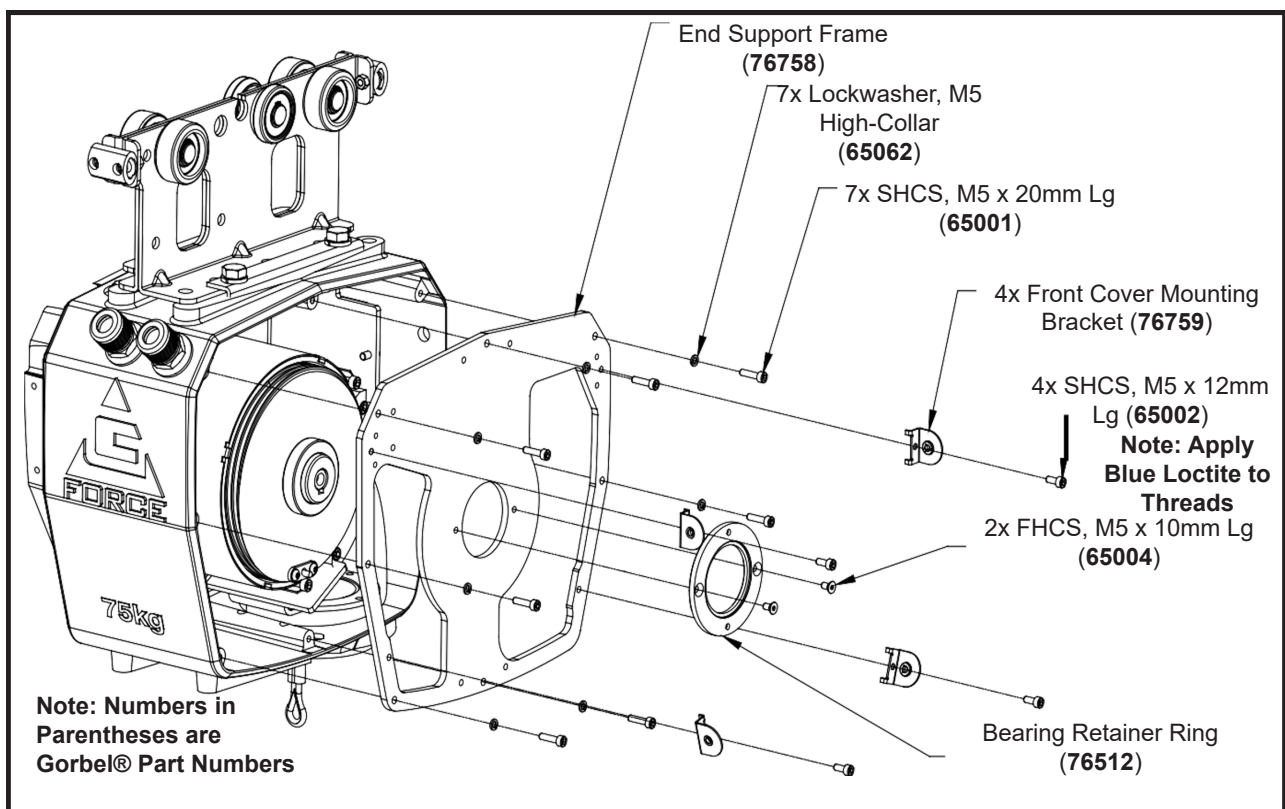

Diagram 11. 165 and 330 lb. (75 and 150 kg) End Support Frame Removal and Replacement.

Note: For 660# and 1320# units replace End Support Frame with 76502, and flip over the Bearing Retainer Ring.

Procedure 12A - Load Cell Removal

1. Turn power off by disconnecting AC power to the system.
2. Remove front cover. Refer to Procedure 1A.
3. Remove rear cover. Refer to Procedure 2A.
4. Disconnect load cell cable from J4 on the main PCB and open cable clamp to free cable and connector for removal.
5. Remove the M12 hex head cap screw (HHCS) and M12 lockwasher that secures the load cell to the main middle section through the opening towards the motor end of the main middle section. Note: Be careful not to damage any wiring as you pull the load cell cable through the main middle section since there is other wiring present.

Procedure 12B - Load Cell Replacement

1. Position the load cell (with the pin attached) in place from the motor end of the main middle section.
2. Install the M12 hex head cap screw (HHCS) and M12 lockwasher that secure the load cell to the main middle section.
3. Connect the load cell cable connector to J4 on the main PCB and secure the cable with the corresponding clamp.
4. Install the front cover. Refer to Procedure 1B.
5. Install the rear cover. Refer to Procedure 2B.
6. Restore AC power to the system

Note: If you are replacing the load cell, you will have to perform specific load cell diagnostic procedures described in the Configuration Menu. Contact Gorbel® After the Sales Support for assistance.

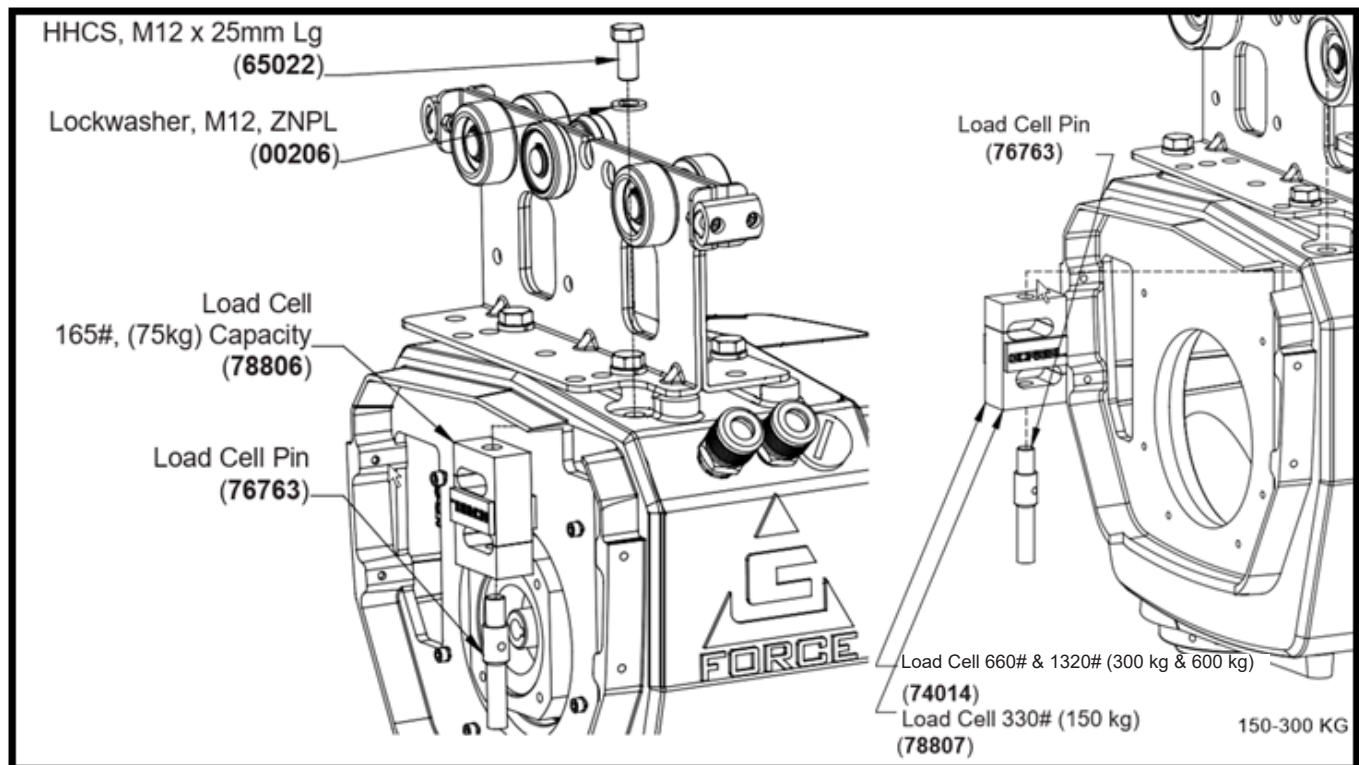
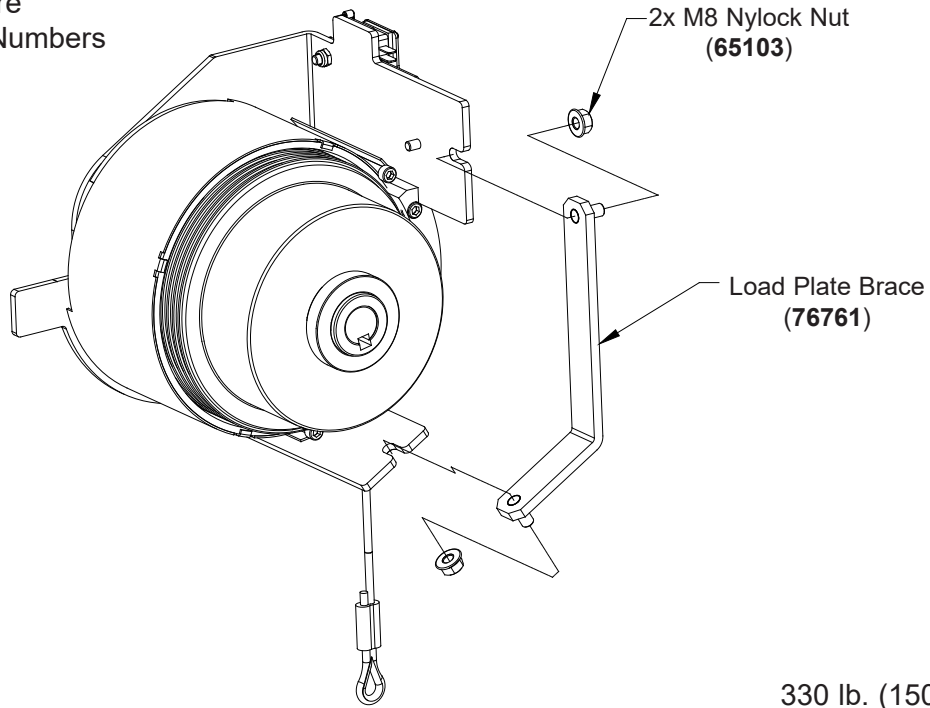

Diagram 12. Load Cell Removal and Replacement. Observe Load Cell Orientation for 165# (Left) vs. 660# & 1320# (300 kg & 600 kg) (Right)

Note: Numbers in Parentheses are Gorbel® Part Numbers



330 lb. (150 kg) Model Only

Load Plate Brace.

Note: Numbers in Parentheses are Gorbel® Part Numbers

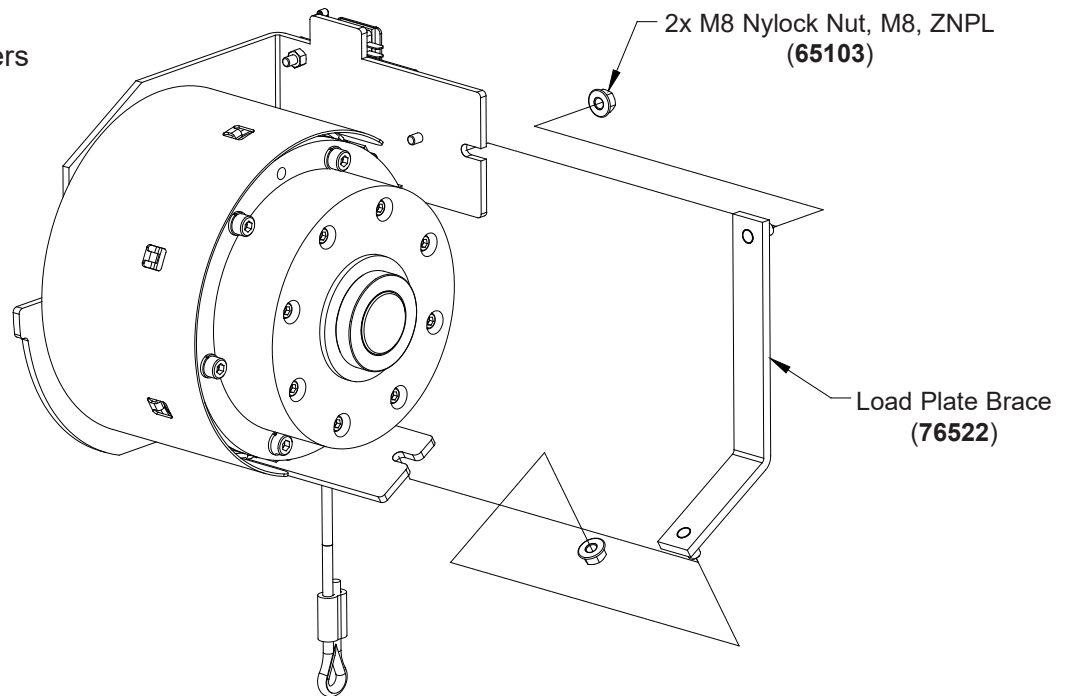

660 lb. (330 kg) Model Only

Load Plate Brace.

Note: 165 lb. (75 kg) models do not use this component.

Procedure 13A - Drum Cover and Drum Cover Band Removal

1. Turn power off by disconnecting AC power to the system.
2. Remove front cover. Refer to Procedure 1A.
3. Remove end support frame. Refer to Procedure 9A.

Note: Use caution during the next step. The drum cover band will be in tension.

4. Remove the (2) M6 socket head cap screws (SHCS) and M6 lockwashers that secure the drum cover band to the load plate.
5. Slide both the drum cover band and drum cover off the drum pulley.

Procedure 13B - Drum Cover and Drum Cover Band Replacement

1. Position the drum cover band inside the drum cover and slide the assembly over the drum pulley.
2. Install the (2) M6 socket head cap screws, SHCS and (2) M6 lockwashers for the drum cover band into the load plate.
3. Install the end support frame. Refer to Procedure 9B.
4. Install the front cover. Refer to Procedure 1B.
5. Restore power to the system.

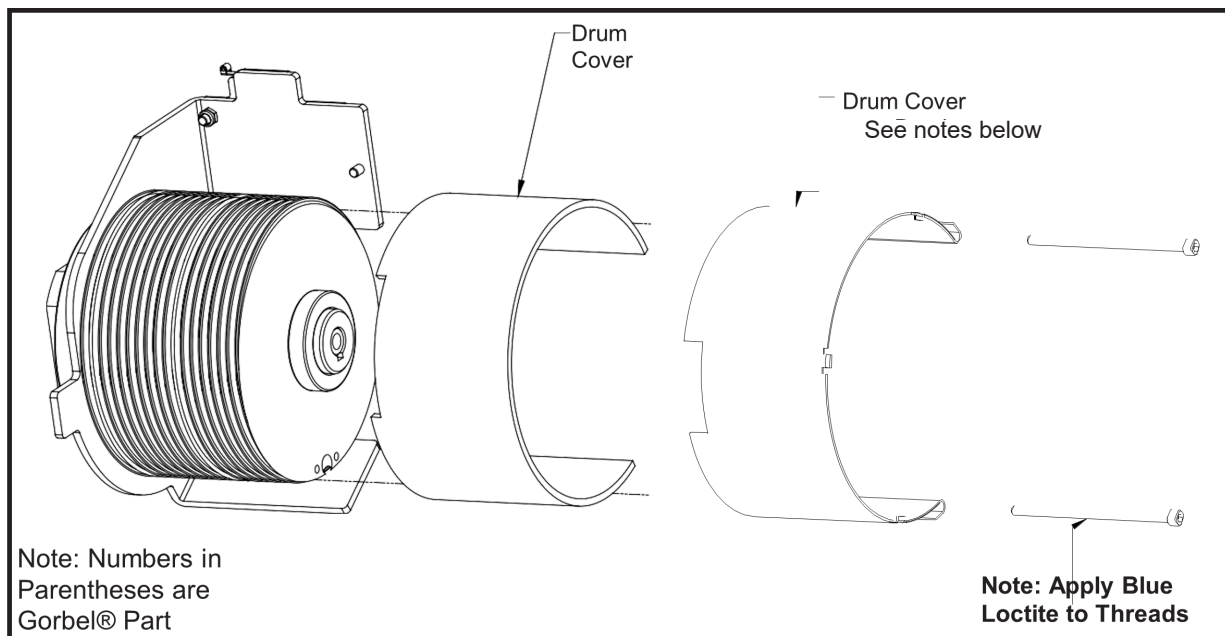

Diagram 13a. Drum Cover and Band Removal and Replacement.

Notes:

- a. 165 lb. (75 kg) and 330 lb. (150 kg) units use Drum Cover (76703), Drum Cover Band (76702), and 2x SHCS, M6 x 110mm Lg (65037).
- b. 660 lb. (300 kg) units use Drum Cover (76513), Drum Cover Band (76509), and 2x SHCS, M6 x 90mm Lg (65030).

Procedure 14A - Drum Gate Removal

1. Turn power off by disconnecting AC power to the system.
2. Remove the front cover. Refer to Procedure 1A.
3. Remove the (4) M5 button head cap screws, BHCS and (4) M5 lockwashers that secure the PCB / ACOPOS support bracket assembly to the end support frame.
4. Disconnect limit switch cable assembly from main PCB in order to swing the ACOPOS drive assembly into the open position for access to the drum gate area.
5. Loosen the (2) M8 nylock nuts and remove the load plate brace if your unit is a 330 or 660 lb. (150 or 300 kg) model.
6. Remove the (2) M6 socket head cap screws, SHCS and (2) M6 lockwashers from the drum gate and slide the drum gate off the load plate.

Procedure 14B - Drum Gate Replacement

1. Slide the drum gate into position on the load plate and install the (2) M6 socket head cap screws, SHCS and (2) M6 lockwashers.
2. Position the load plate brace if equipped with one and tighten the (2) M8 nylock nuts.
3. Swing the ACOPOS drive assembly into the closed position and connect the limit switch cable assembly to the main PCB.
4. Install the (4) M5 button head cap screws, BHCS and (4) M5 lockwashers that secure the PCB / ACOPOS support bracket assembly to the end support frame.
5. Install the front cover. Refer to Procedure 1B.
6. Restore AC power to the system.

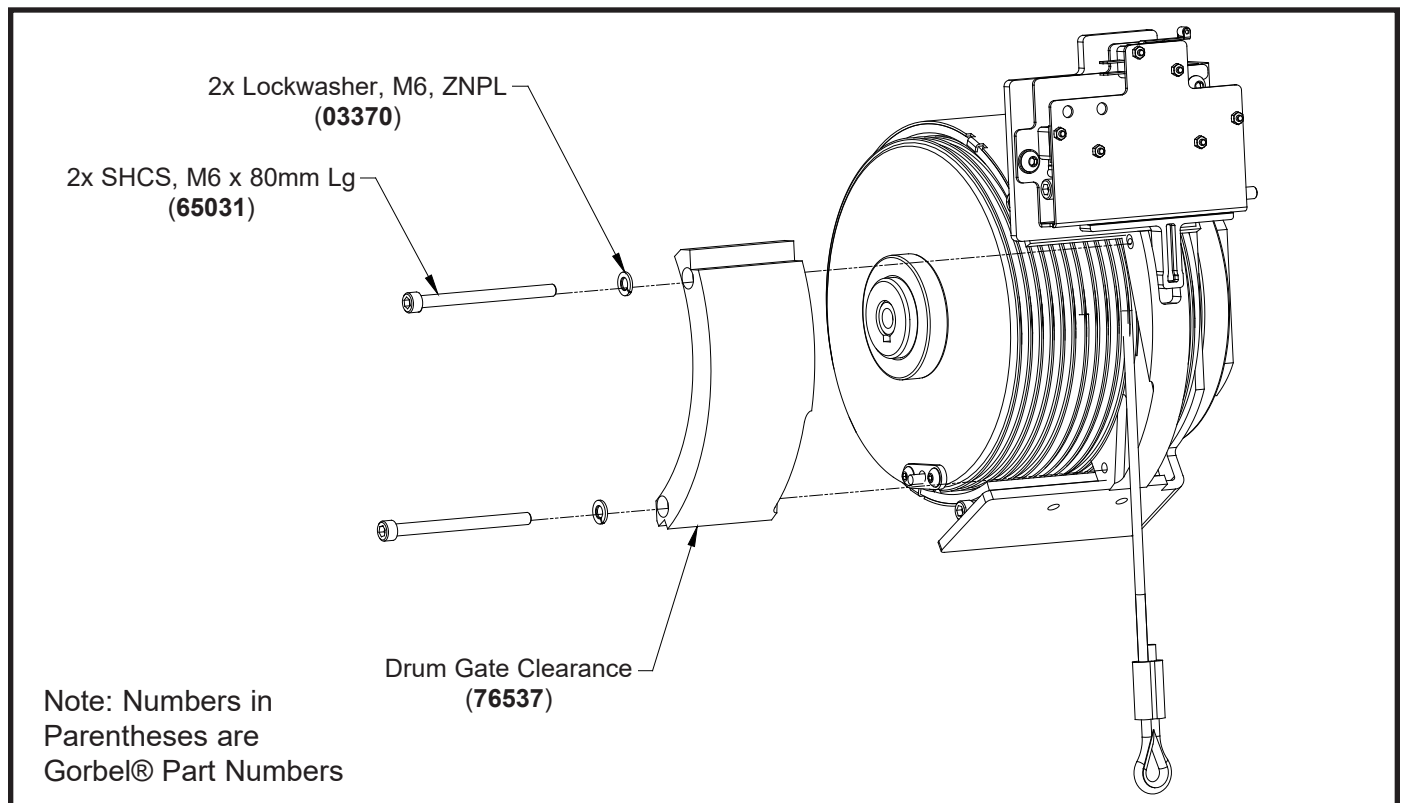

Diagram 14A. 165 lb. (75 kg) and 330 lb. (150 kg) Clearance Drum Gate Removal and Replacement.

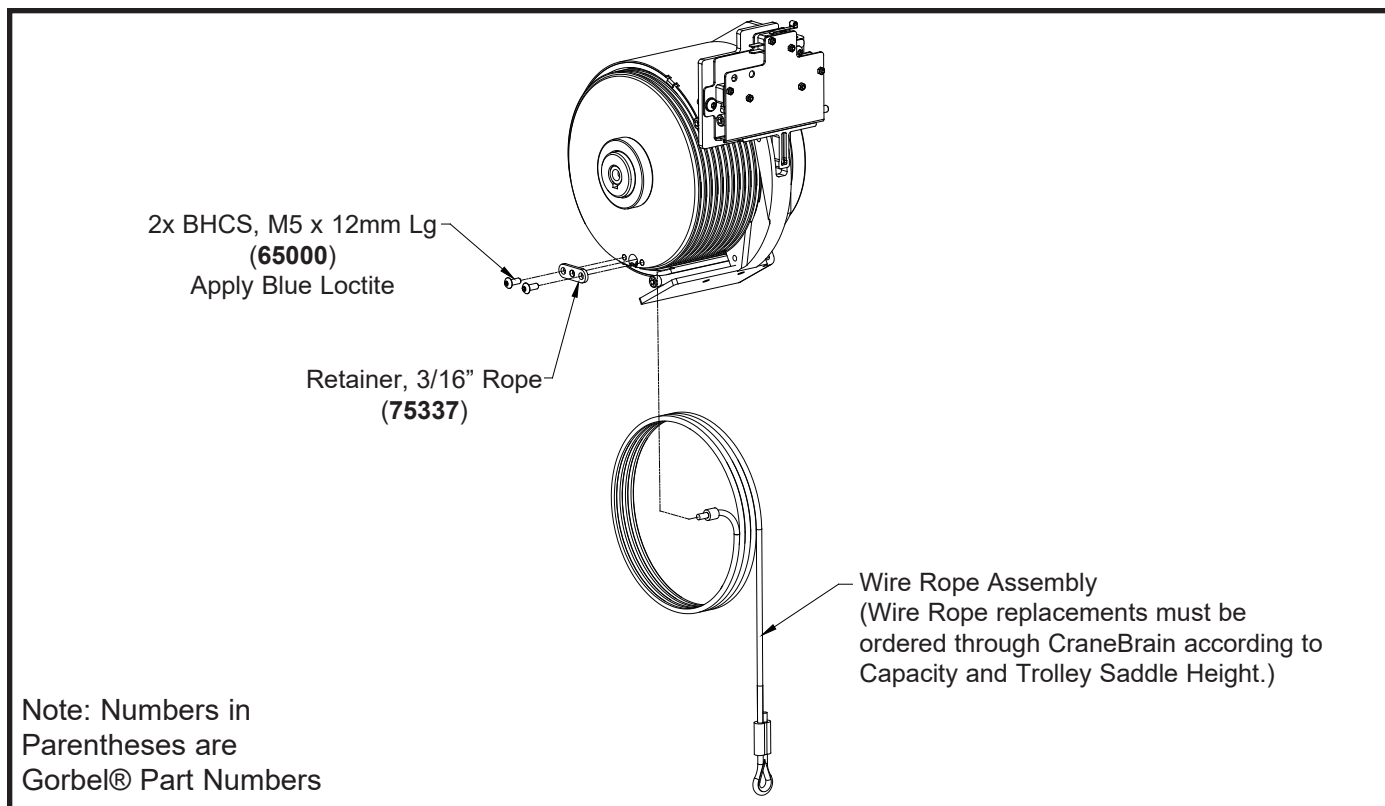

Diagram 14B. 165 lb. (75 kg) and 330 lb. (150 kg) Clearance Drum Gate Removal and Replacement.

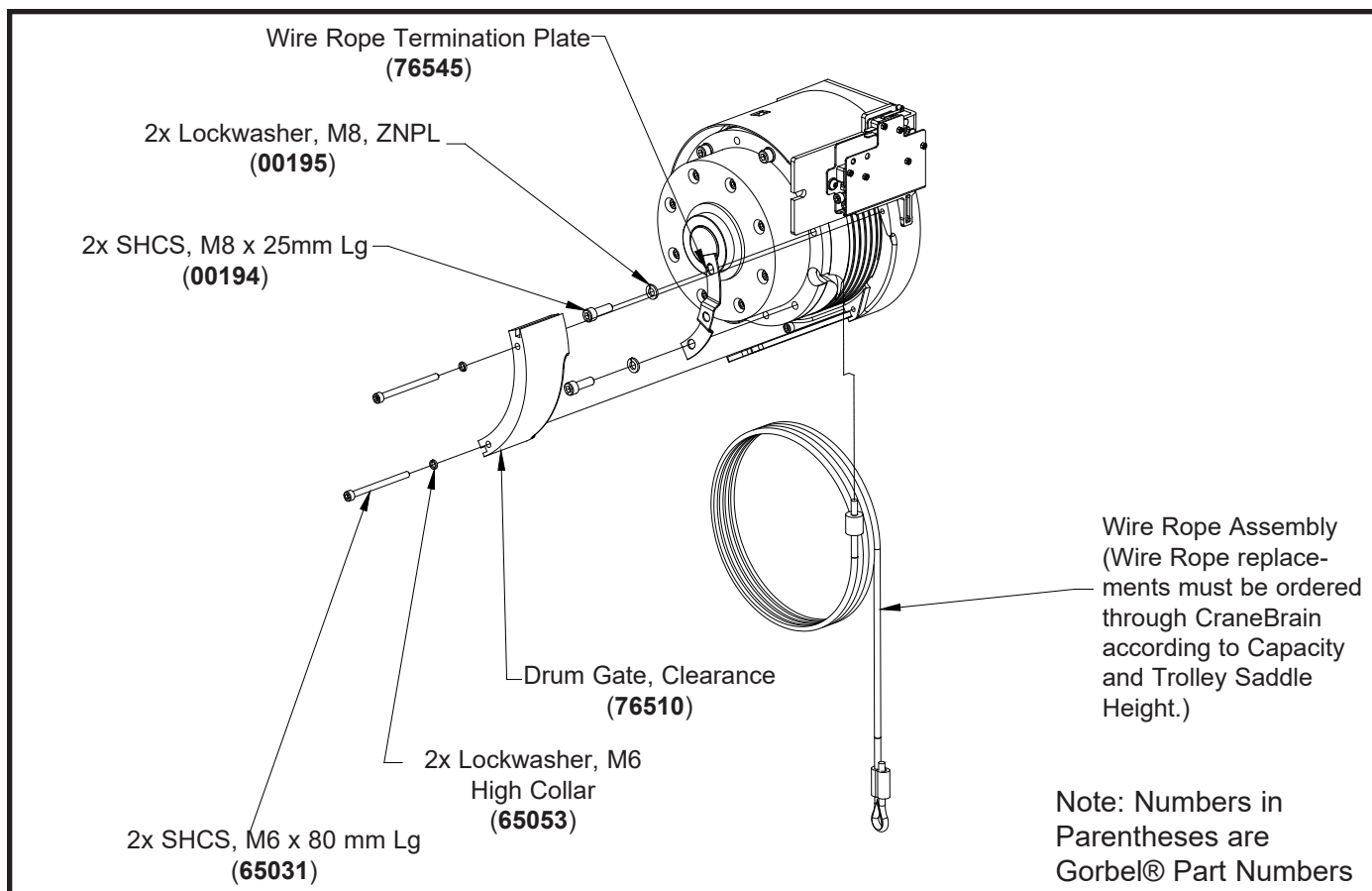

Diagram 14C. 660 lb. (300 kg) Clearance Drum Gate Removal and Replacement.

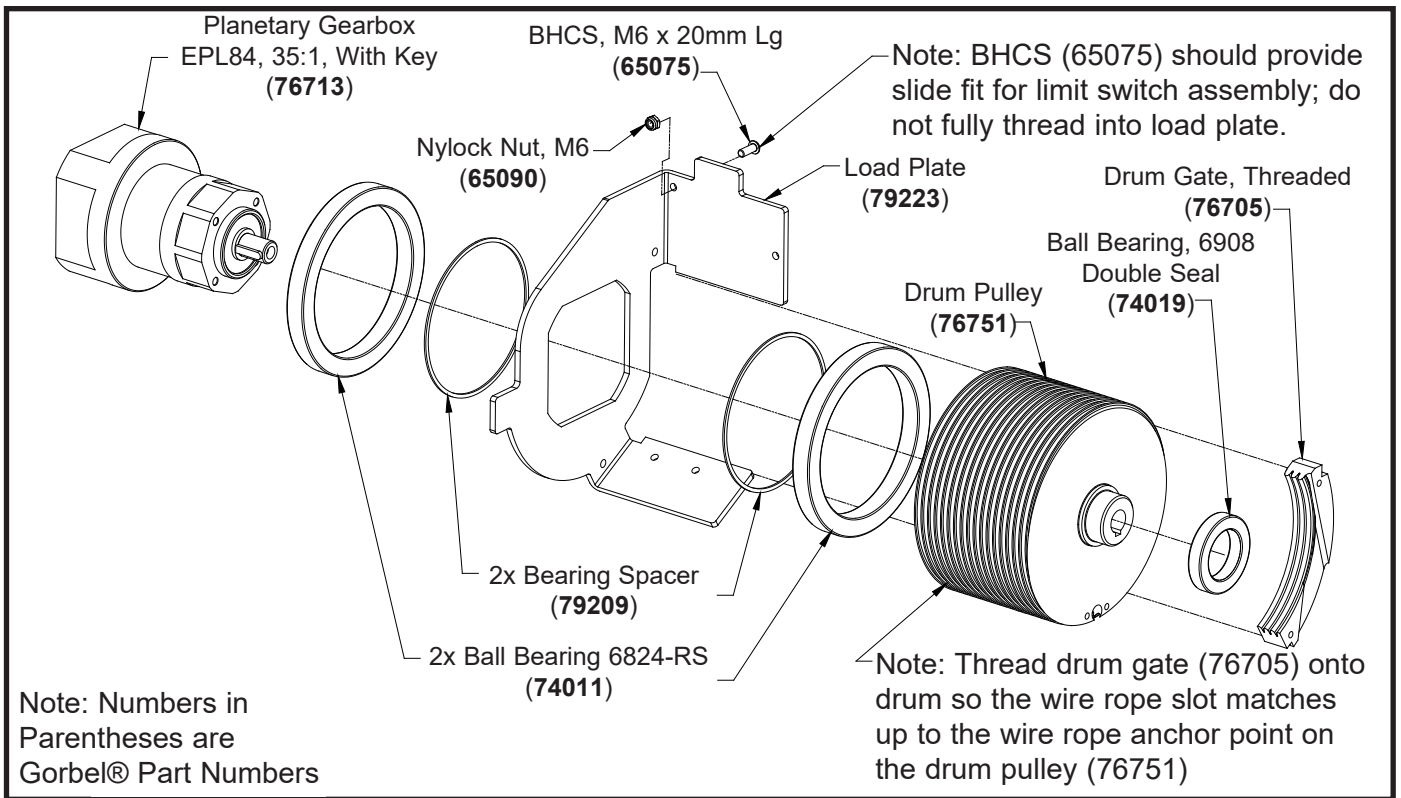

Diagram 14D. 165 lb. (75 kg)

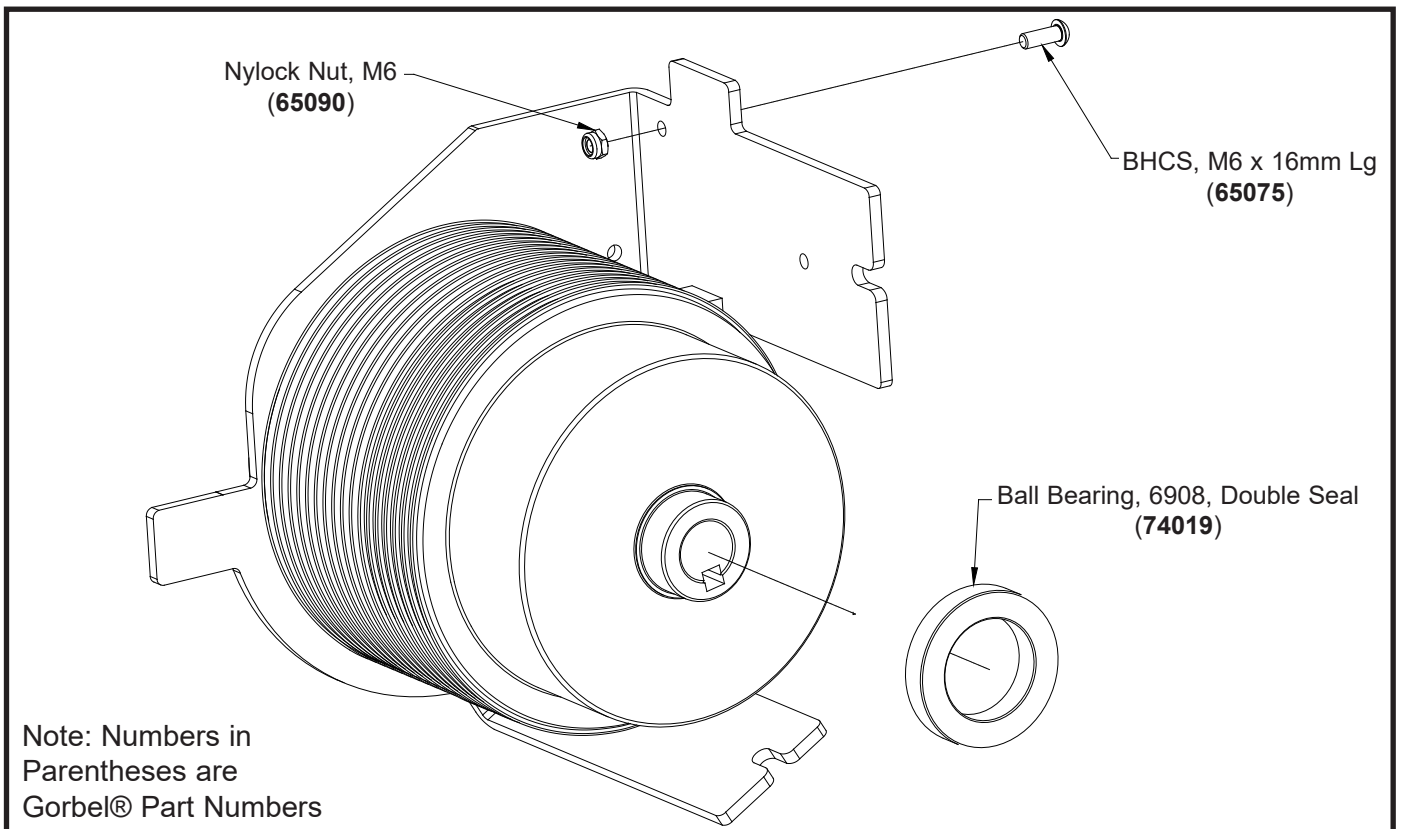

Diagram 14E. 330 lb. (150 kg)

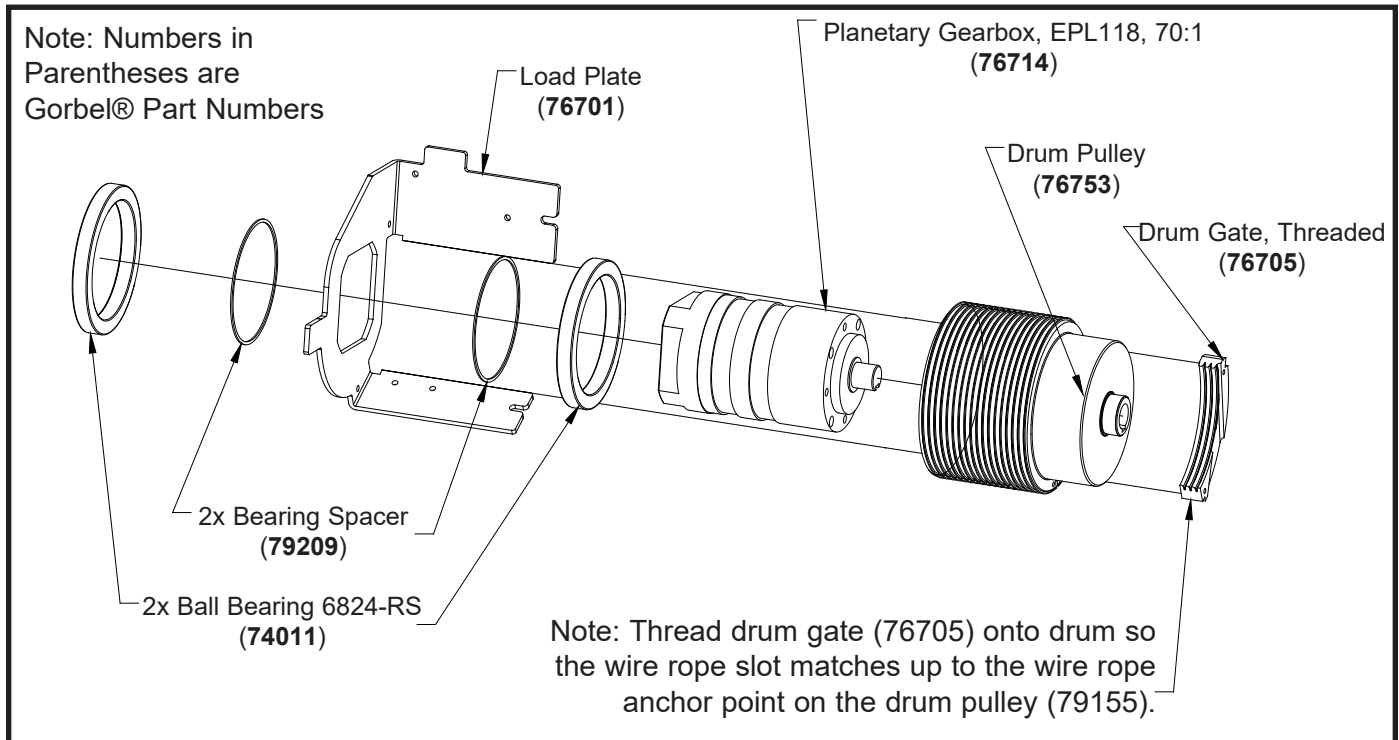

Diagram 14F. 330 lb. (150 kg)

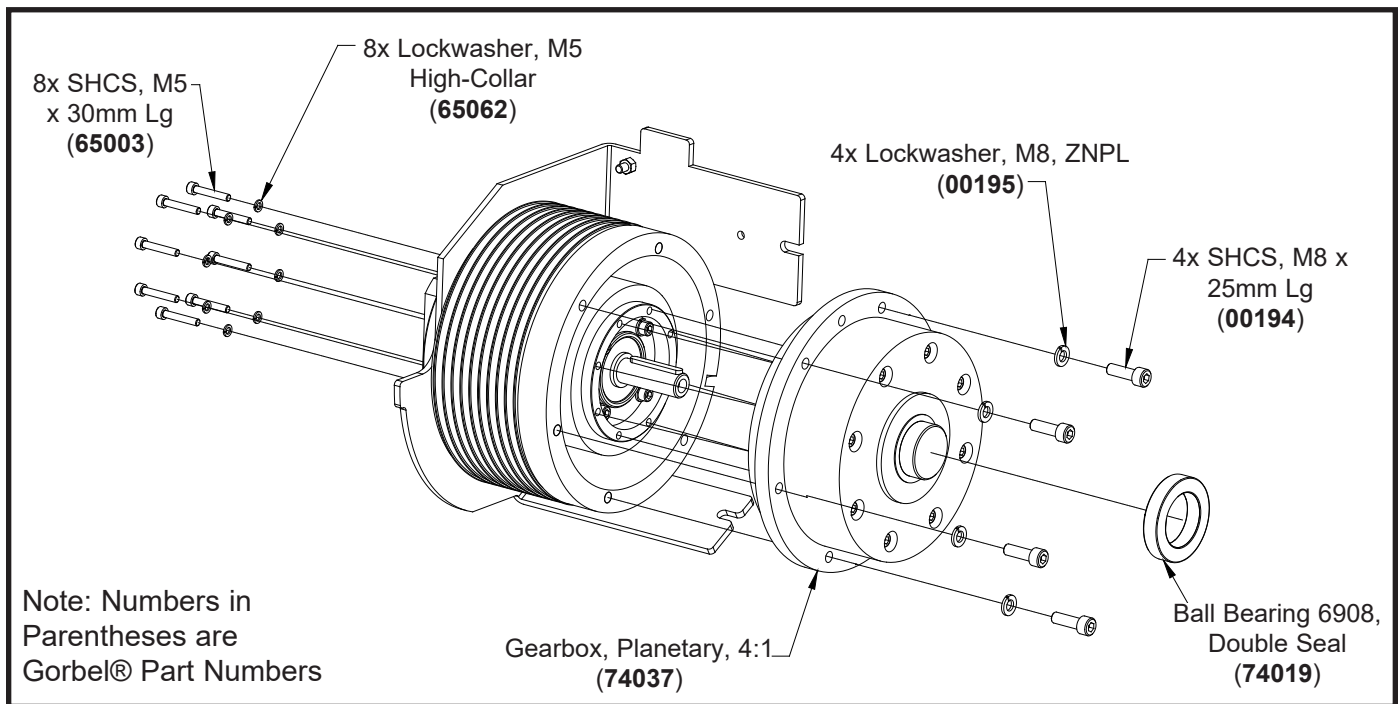

Diagram 14G. 660 lb. (300 kg)

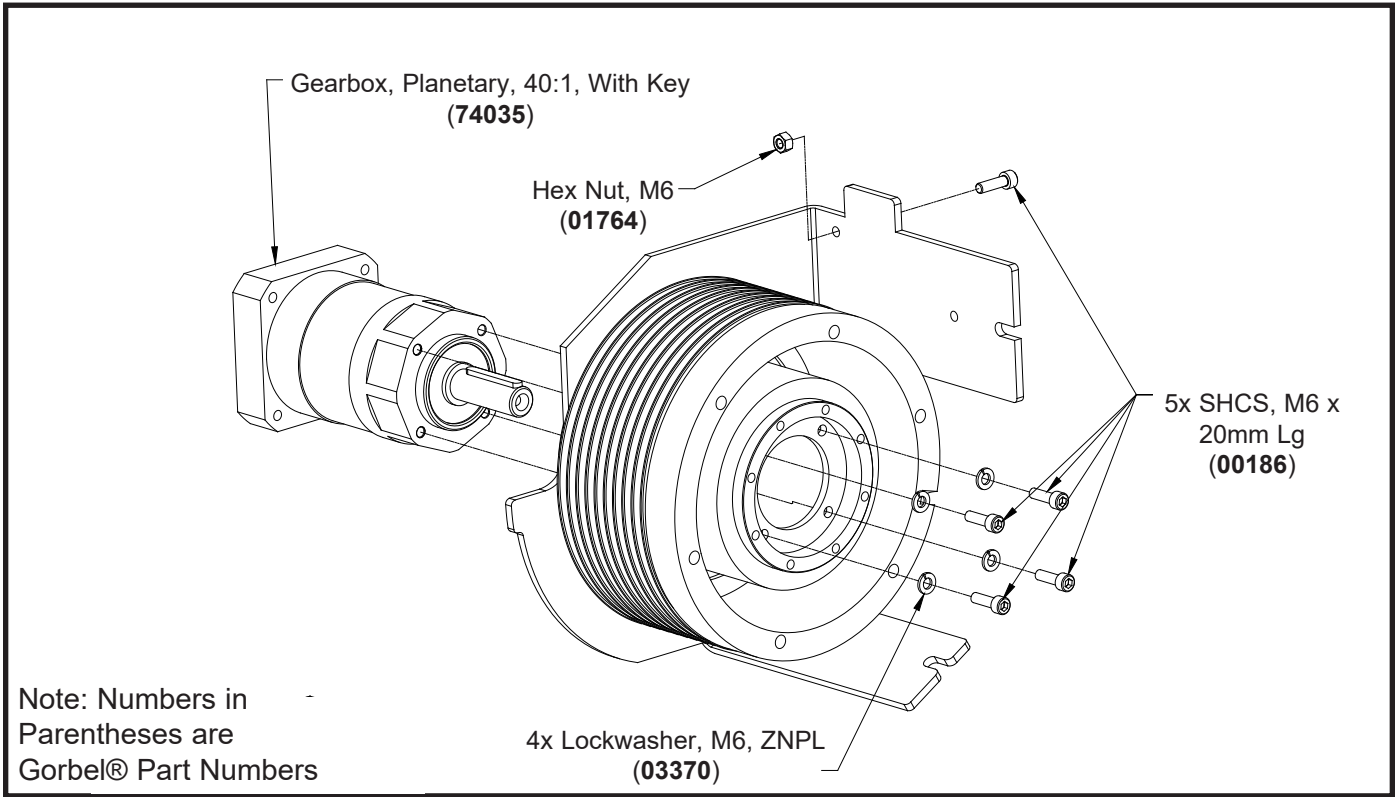

Diagram 14H. 660 lb. (300 kg)

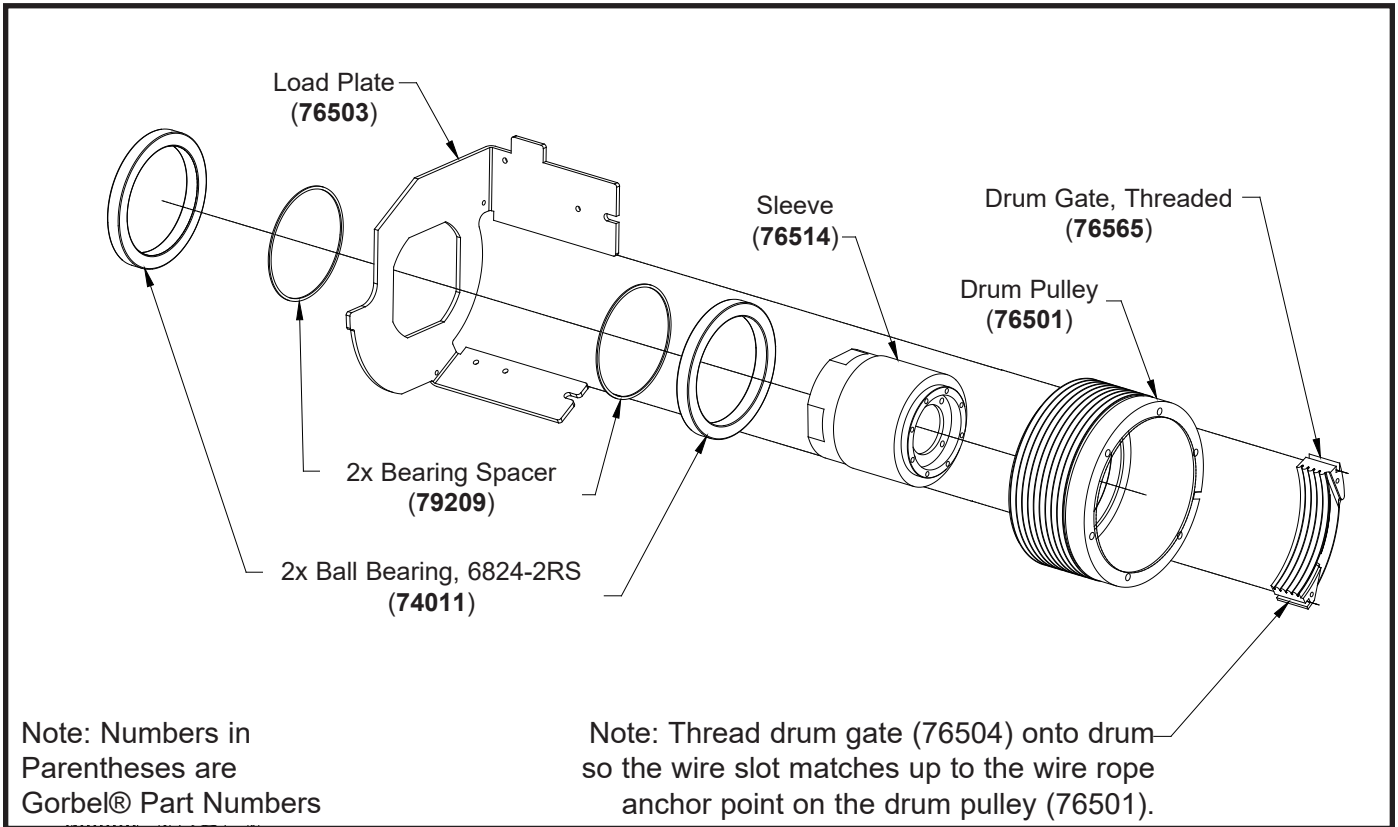

Diagram 14I. 660 lb. (300 kg)

Procedure 15A - Limit Switch Assembly Removal

1. Turn power off by disconnecting AC power to the system.
2. Remove front cover. Refer to Procedure 1A.
3. Disconnect the limit switch cable assembly from the main PCB (J11).
4. Remove the access plug from the main middle section.
5. Remove the M6 button head cap screw (BHCS) and M6 lockwasher from the main PCB end of the limit switch assembly.
6. Remove the limit switch assembly from the load plate inside the main middle section.

Procedure 15B - Limit Switch Assembly Replacement

1. Position the limit switch assembly on the load plate by locating it on the inside M6 button head cap screw (BHCS). The lower projection of the slide must be engaged in the recess in the threaded gate.
2. Install the M6 button head cap screw (BHCS) and M6 lockwasher on the main PCB end of the limit switch assembly.
3. Connect the limit switch cable assembly to the main PCB (J11).
4. Install the access plug into the main middle section.
5. Install the front cover. Refer to Procedure 1B.
6. Restore AC power to the system.

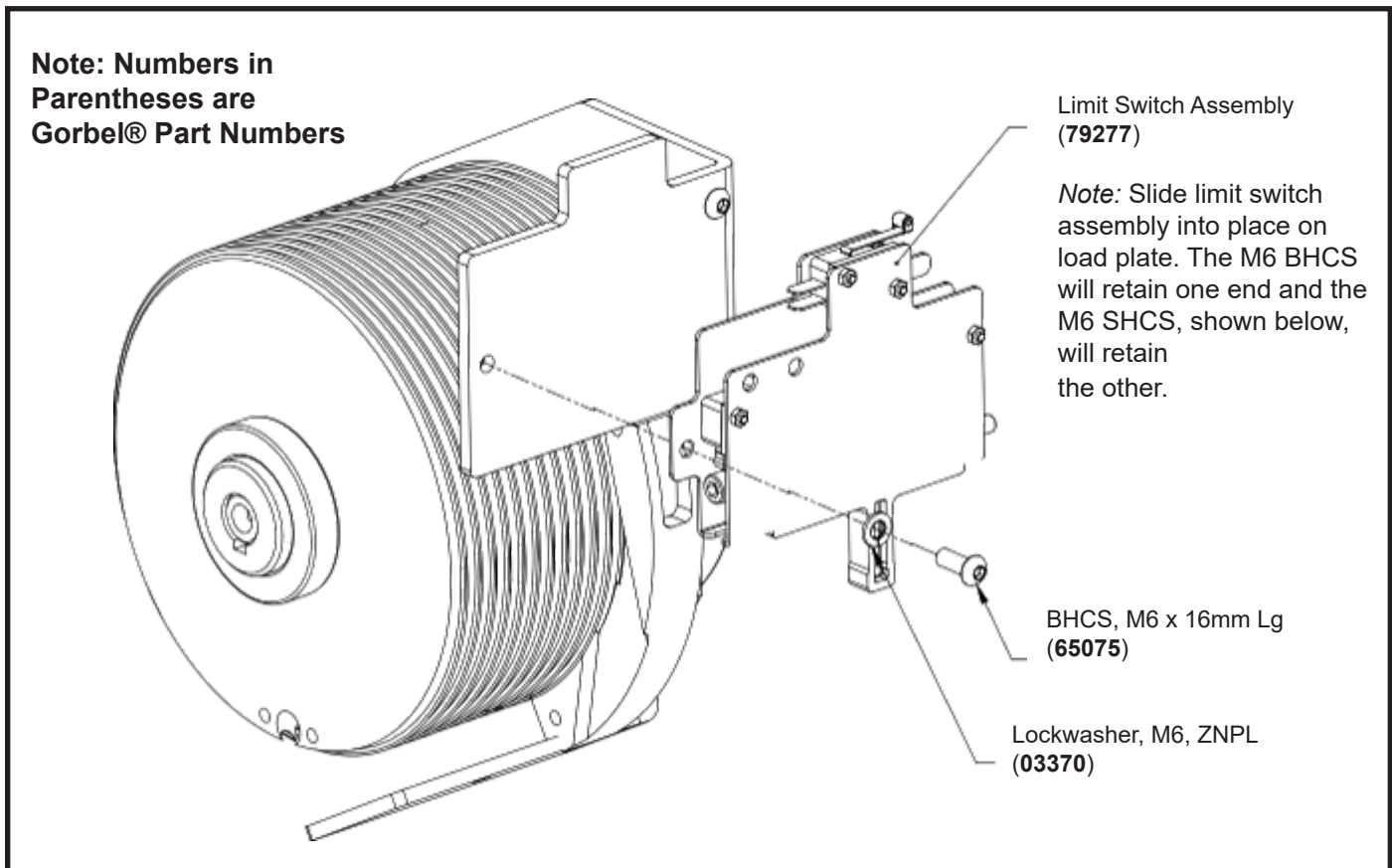
**Diagram 15.** *Limit Switch Assembly Removal and Replacement.*

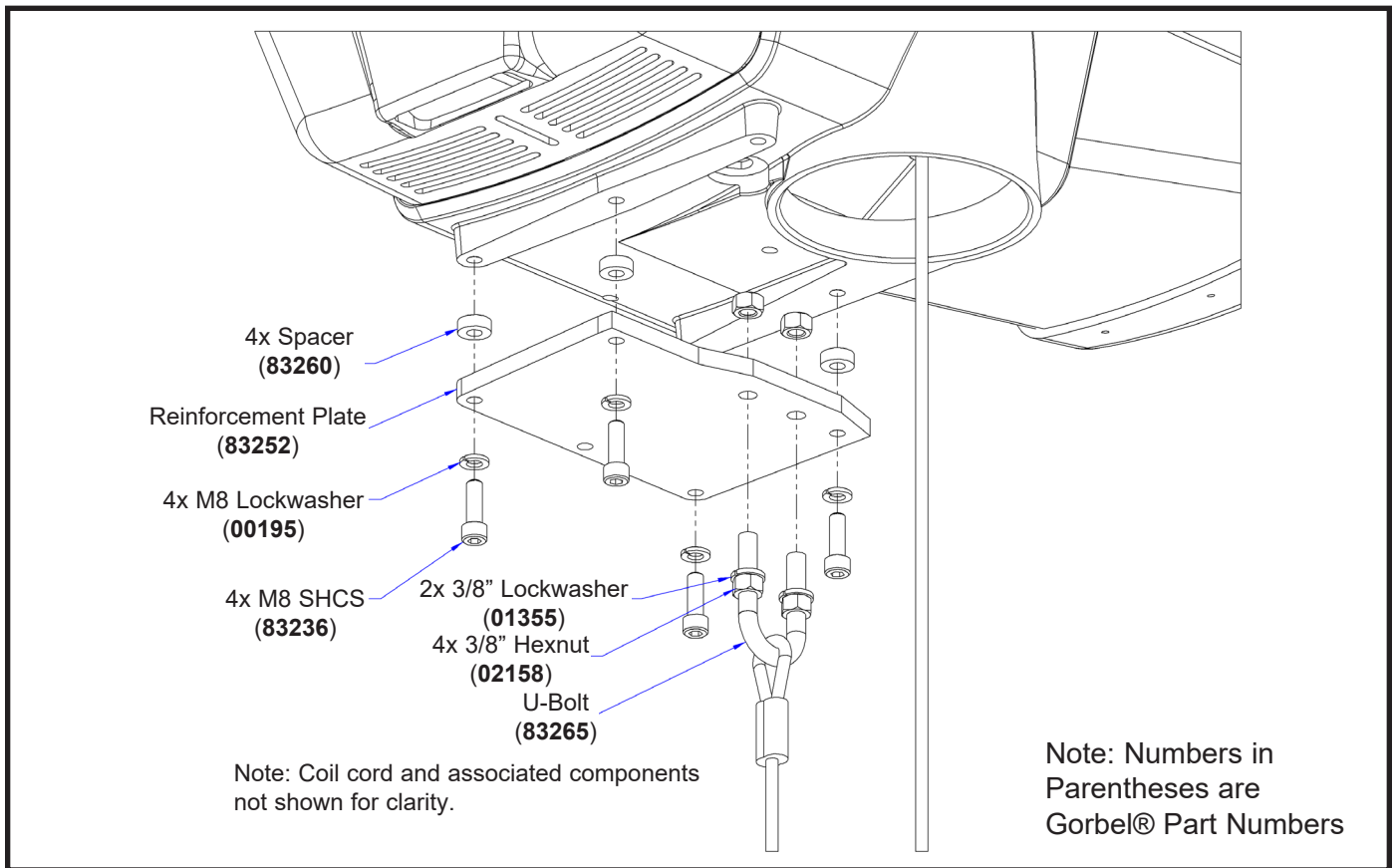

1320 lb. (600 kg) Reeved G-Force® Reinforcement Plate Assembly.

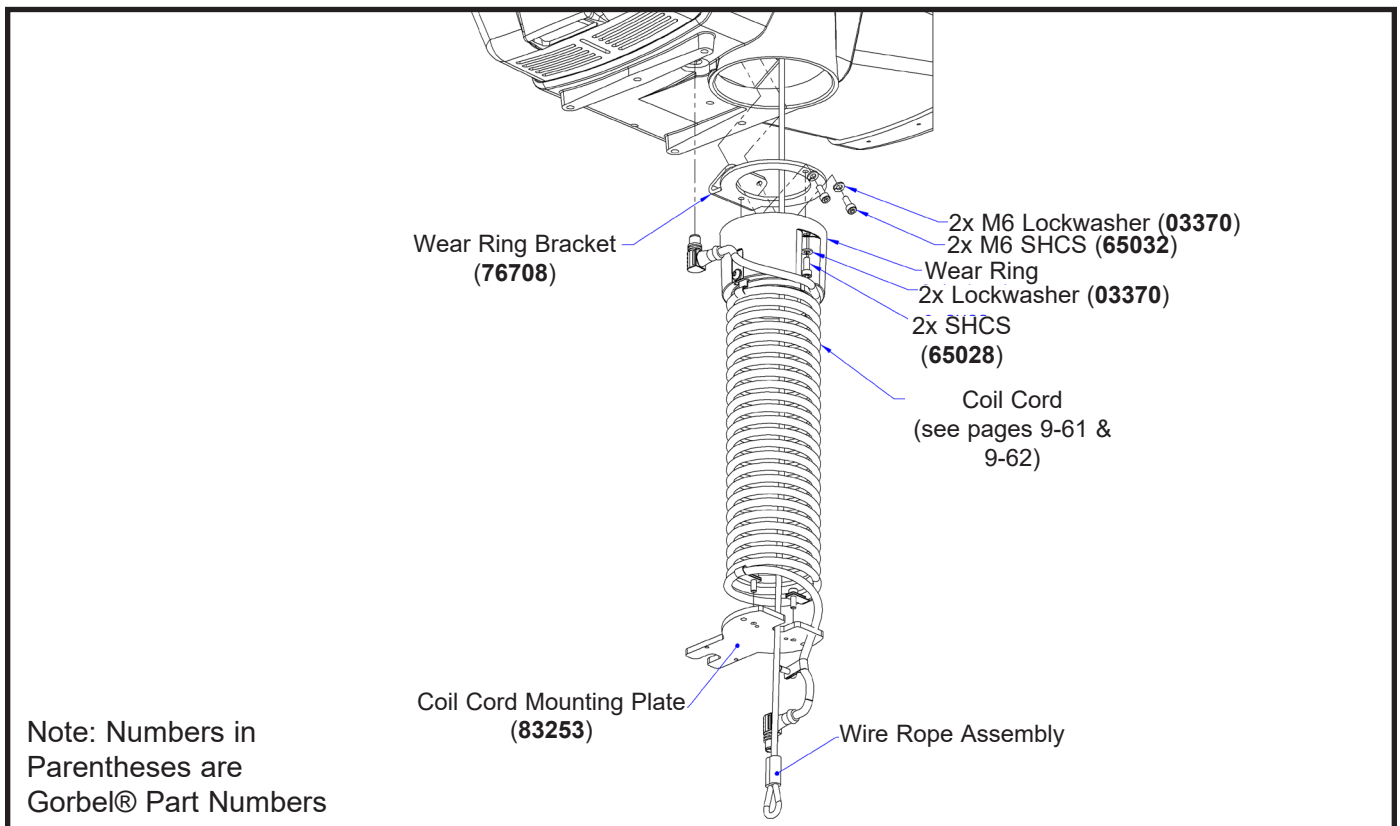

1320 lb. (600 kg) Reeved G-Force® Coil Cord Assembly.

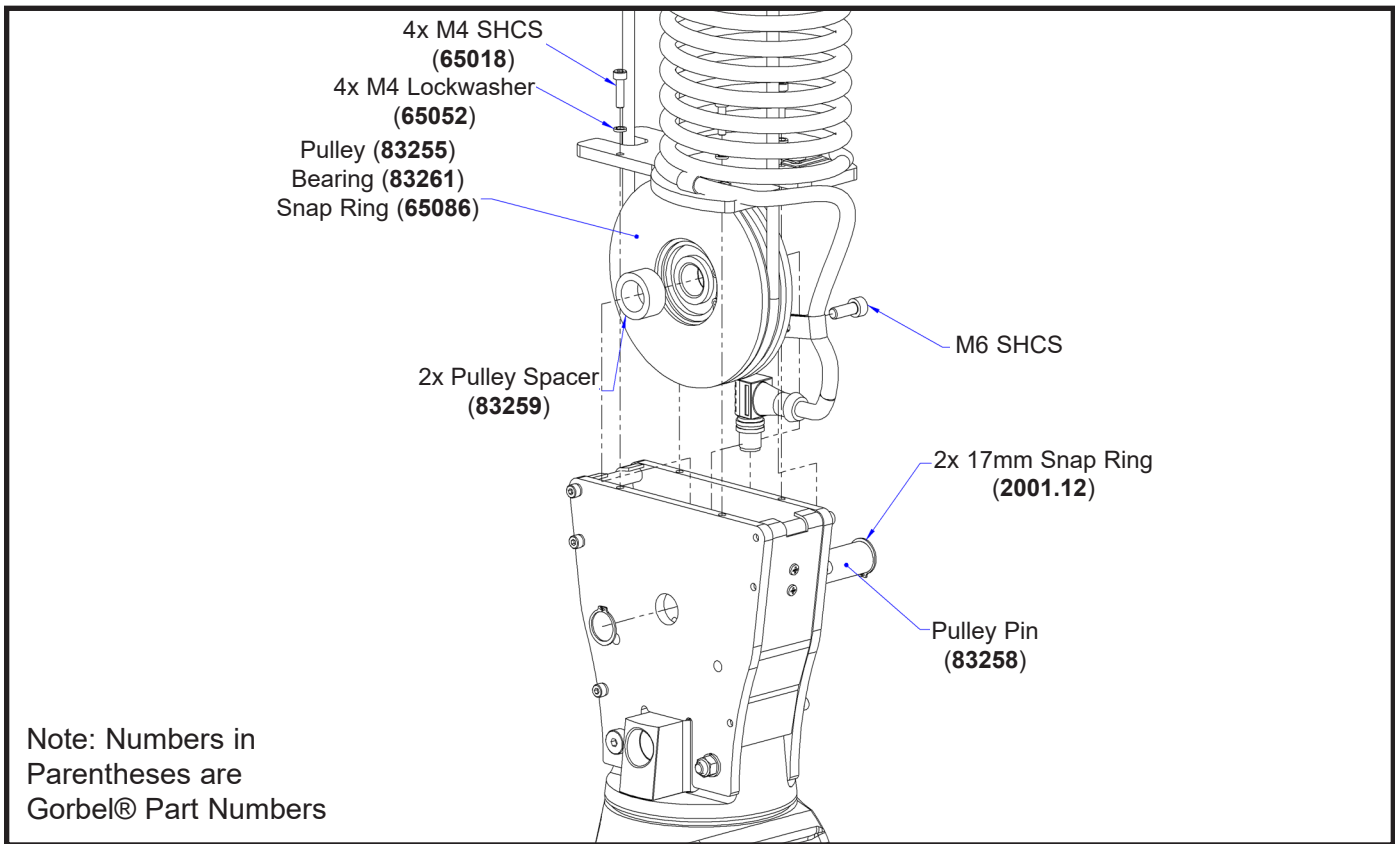

1320 lb. (600 kg) Reeved G-Force Pulley Assembly.

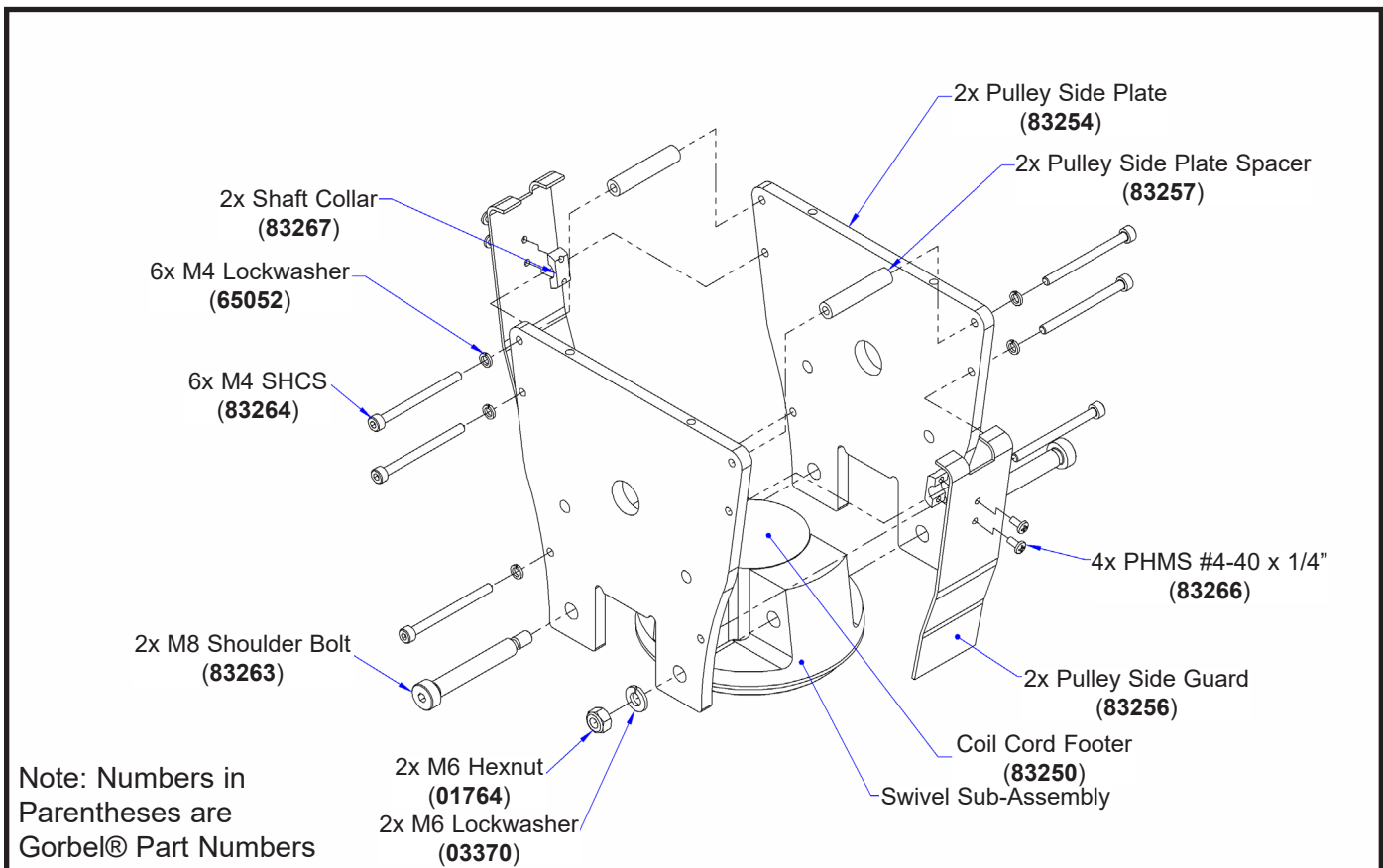

1320 lb. (600 kg) Reeved G-Force® Swivel Assembly.

165-330# G-Force on 1000# NAL Track

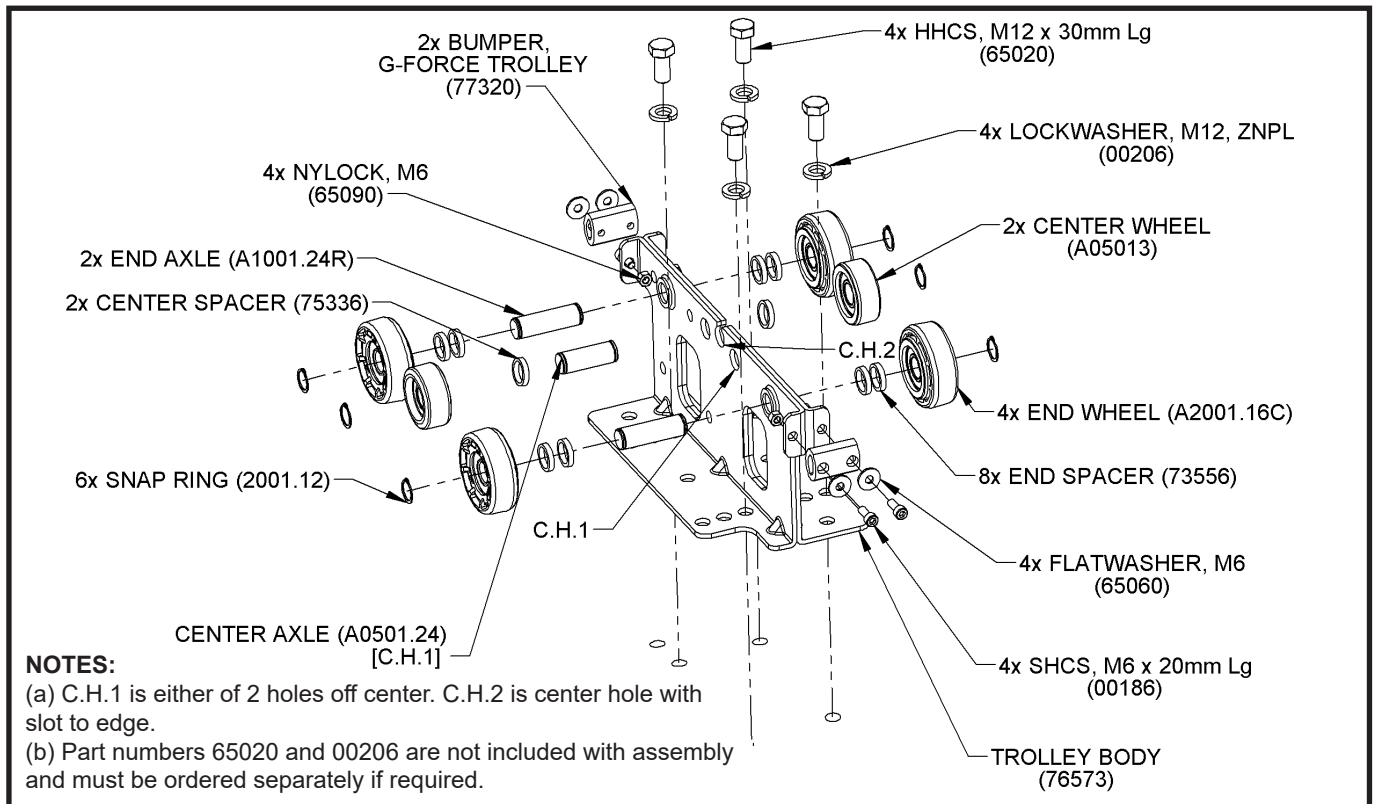

Complete Trolley Assembly (76595)

165-330# G-Force on 500# Steel Track

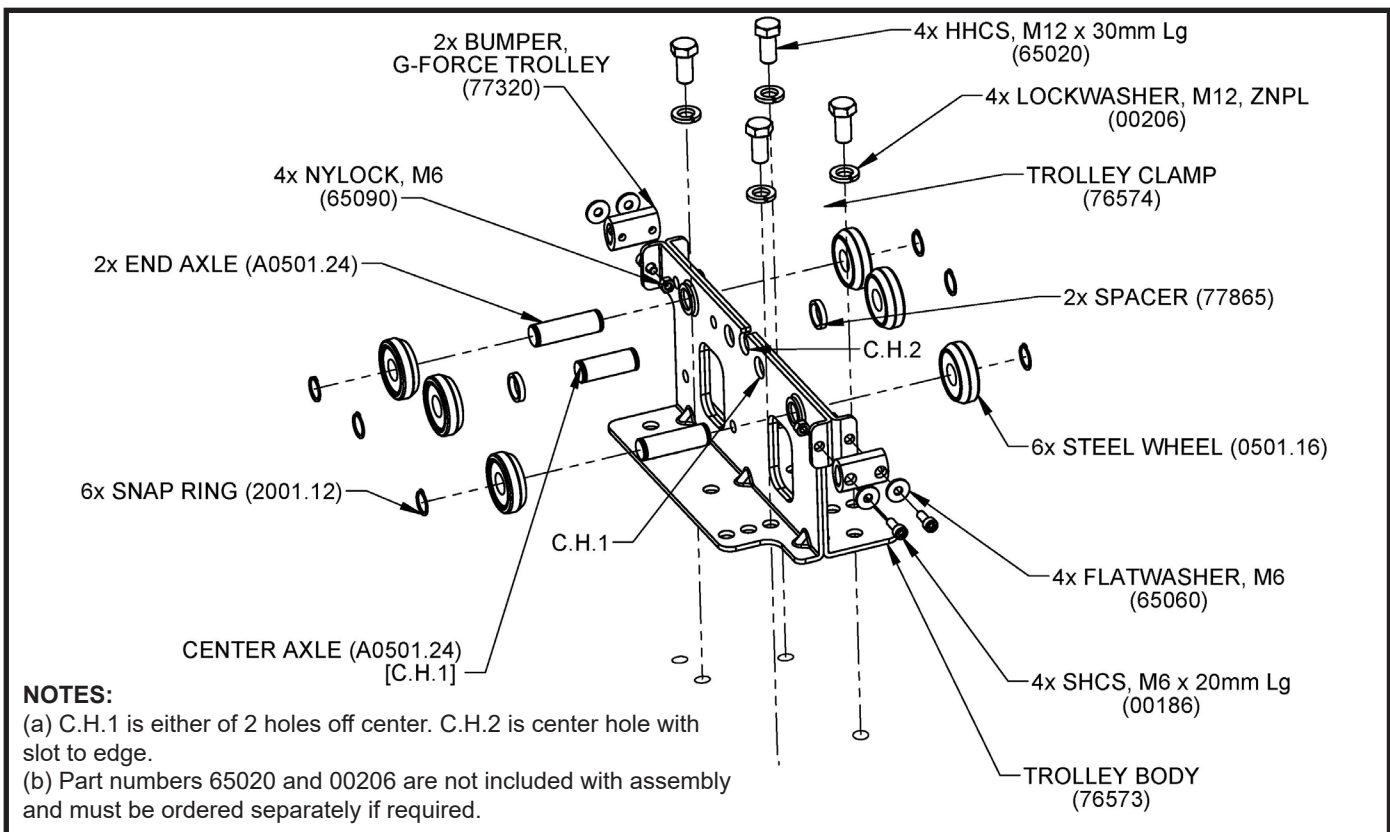

Complete Trolley Assembly (76591)

165-330# G-Force on 2000 - 4000# NAL Track

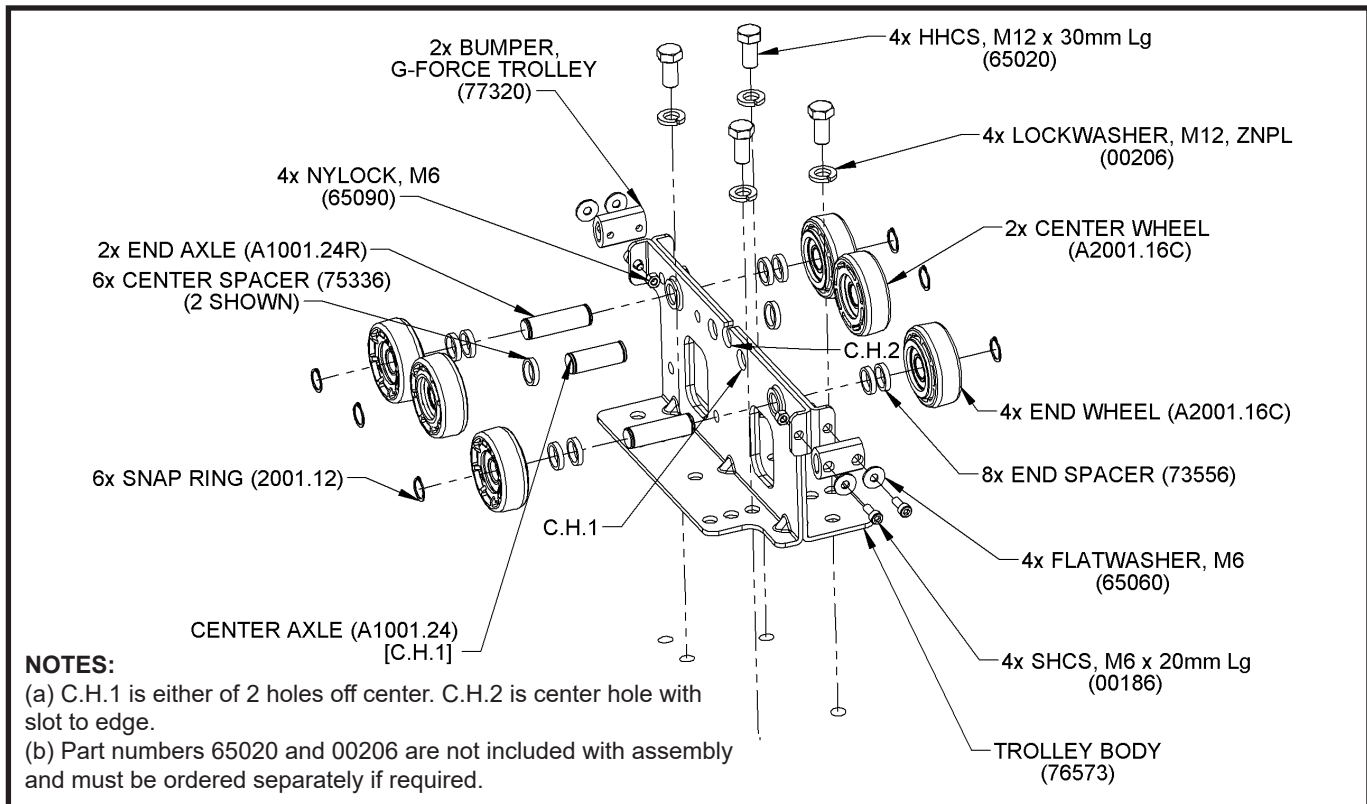

Complete Trolley Assembly (76596)

660-1320# G-Force on 1000 - 4000# NAL Track

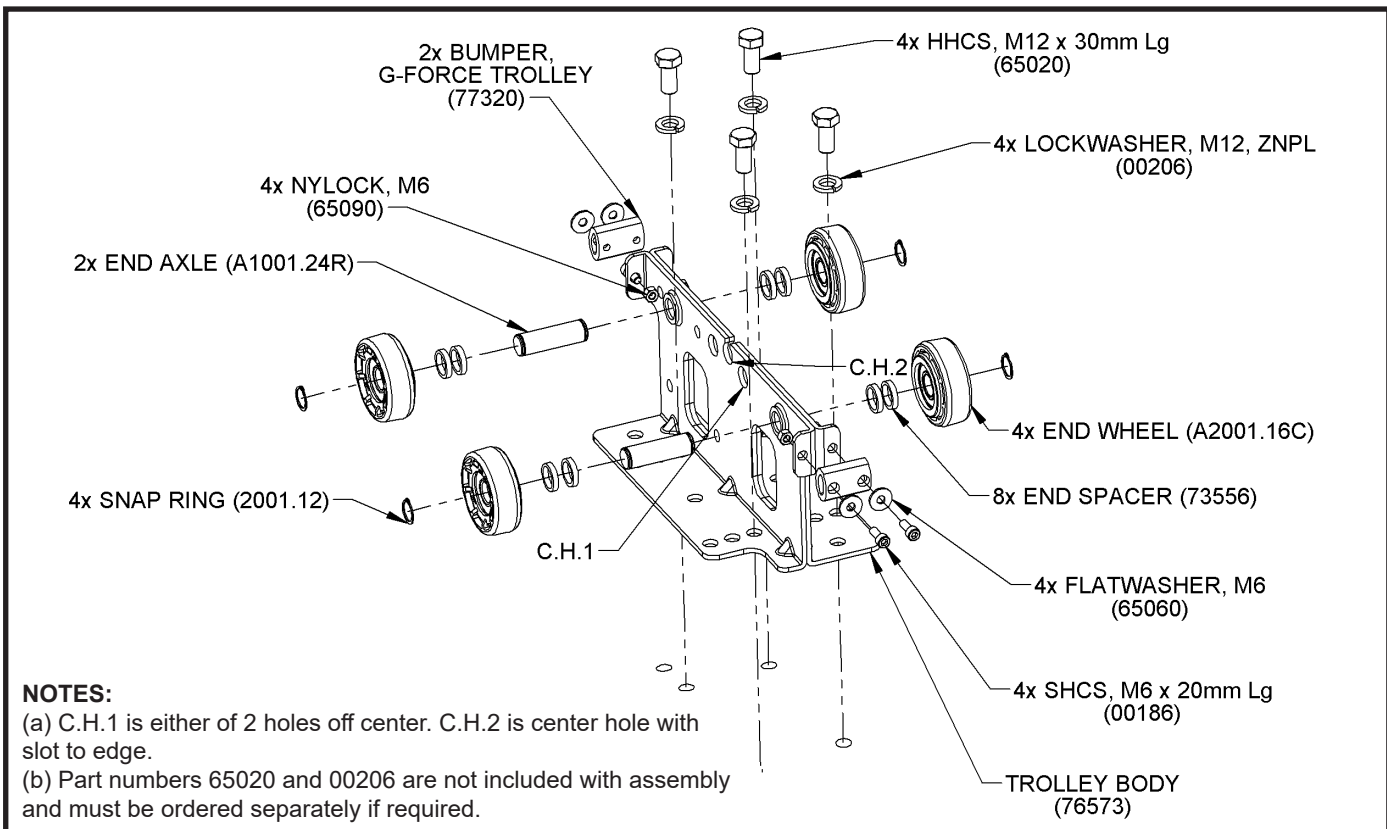

Complete Trolley Assembly (76597)

165-330# G-Force on 250 - 500# Aluminum Track

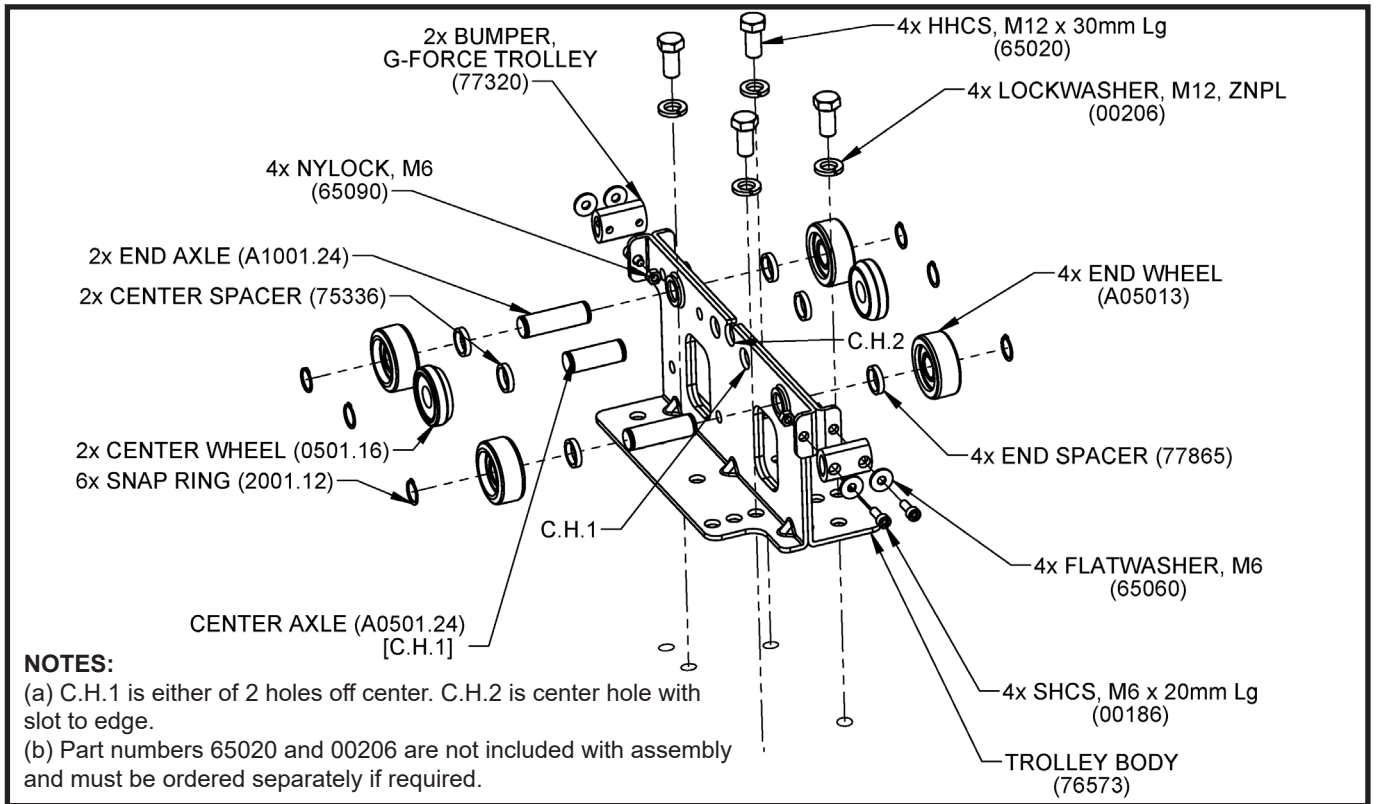

Complete Trolley Assembly (76594)

165 - 330# G-Force on S1000# Steel Track

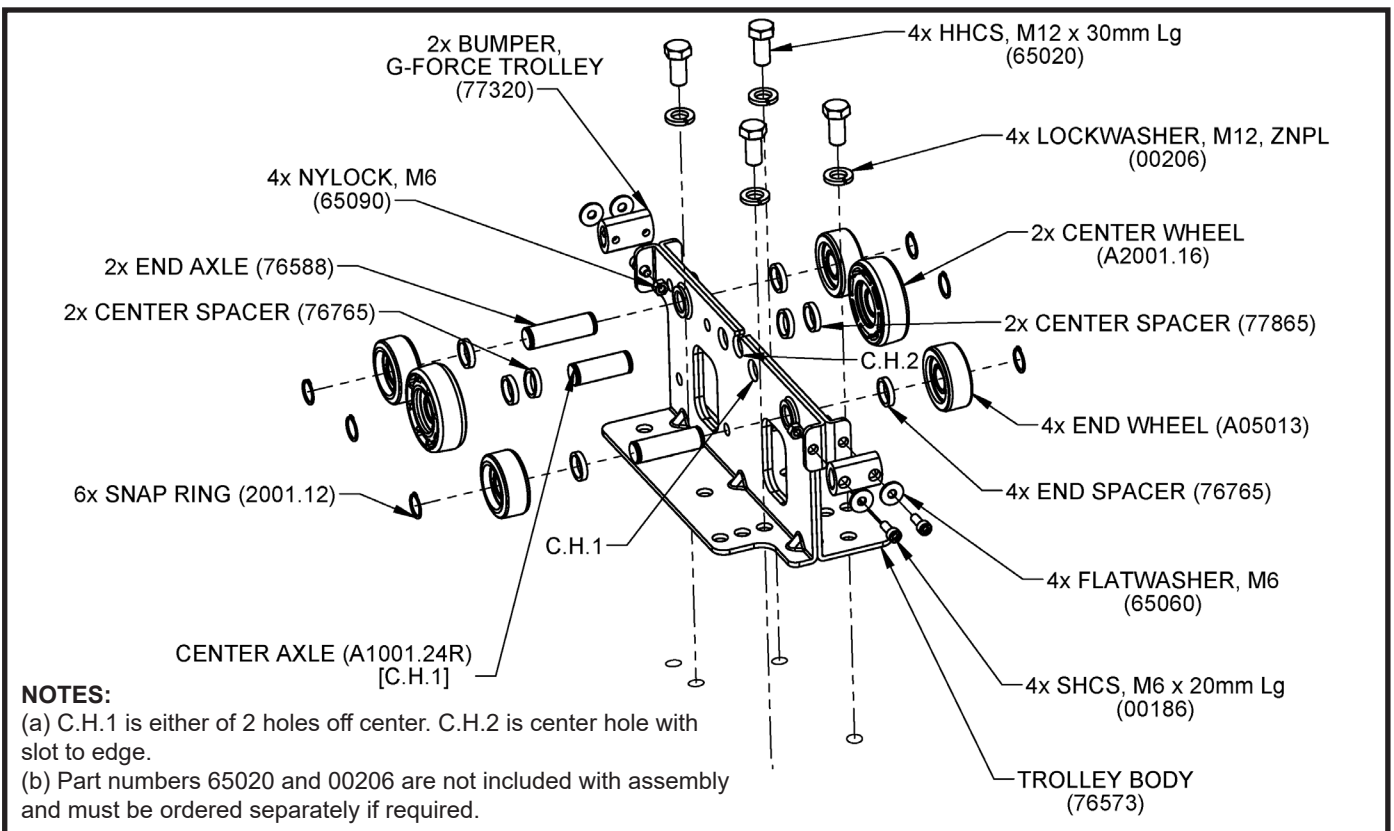

Complete Trolley Assembly (76592)

165-1320# G-Force on S2000# Steel Track

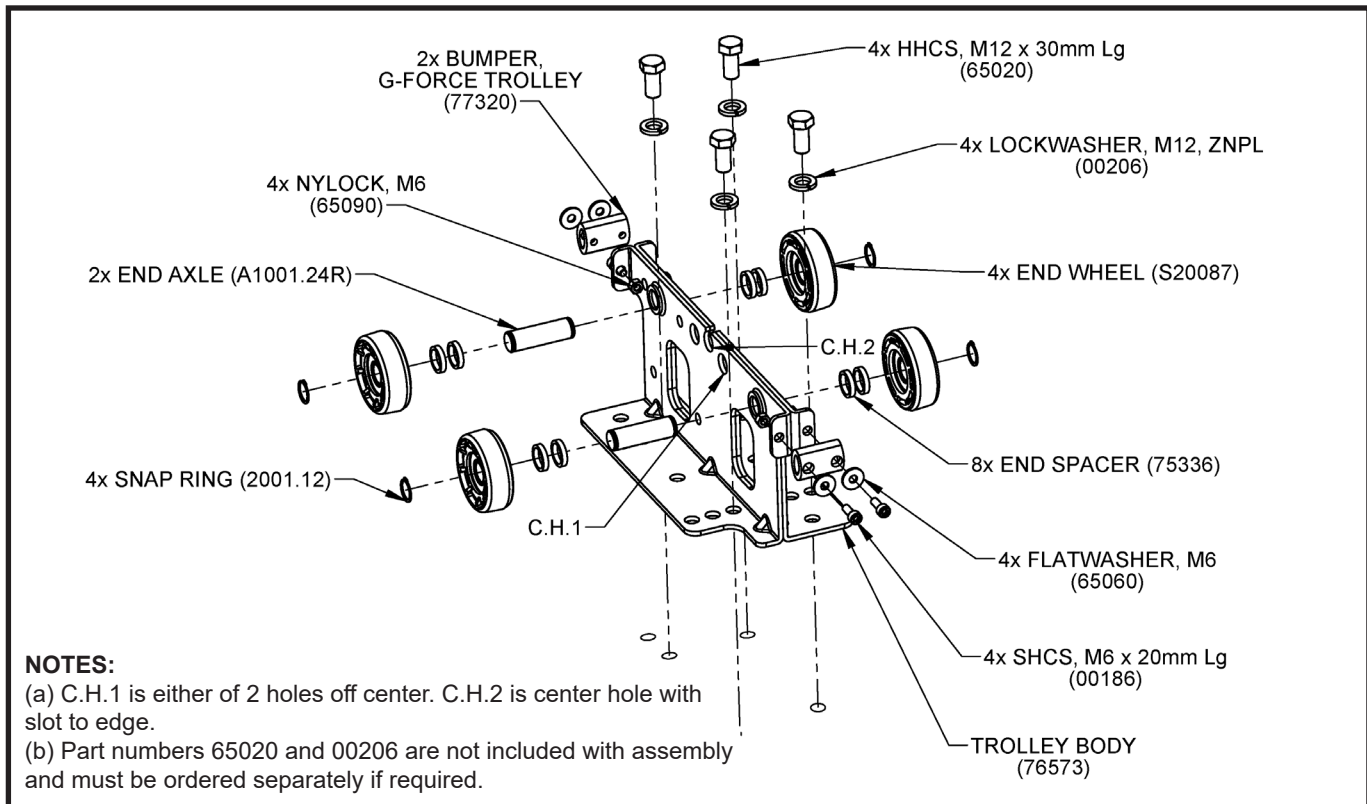

Complete Trolley Assembly (76593)

Universal Adapter Trolley

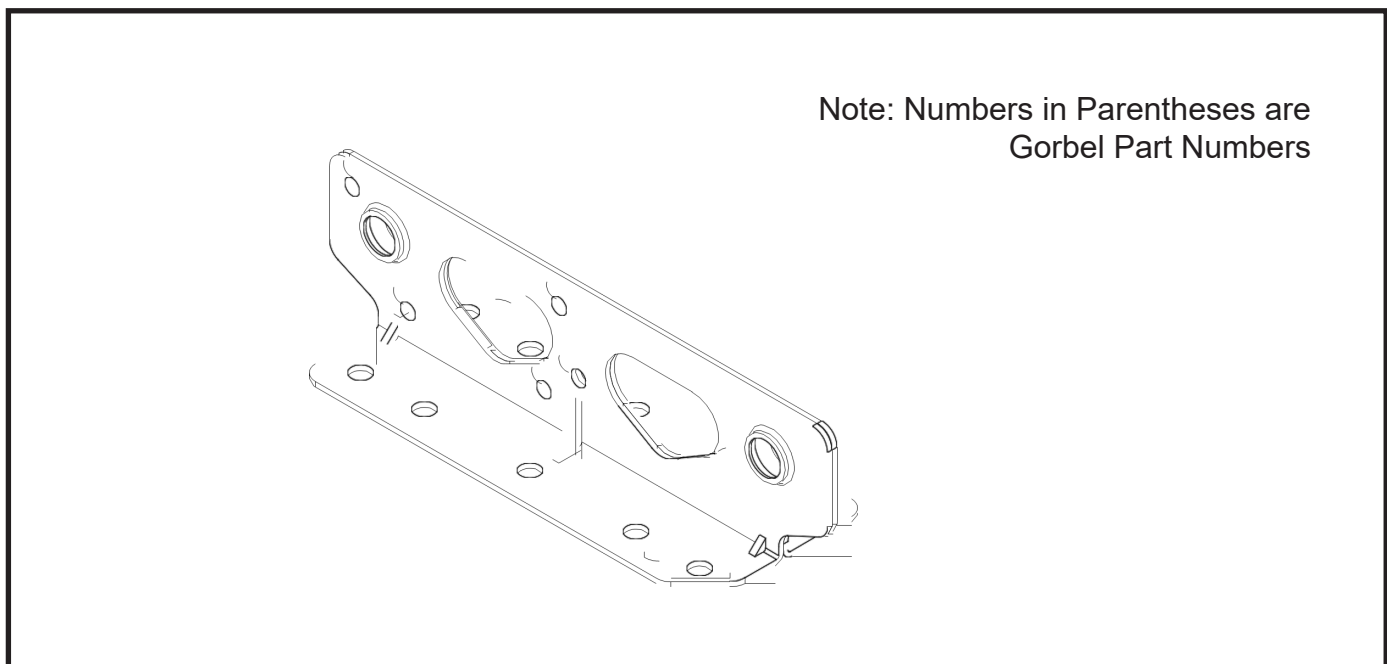

Universal Adapter Trolley (76598)

This page is intentionally left blank.

Removal and Replacement Procedures

SLIDING HANDLE

Procedure S-1A. Swivel Sub-Assembly Removal:

Note: This procedure assumes the Coil Cord and Wire Rope assemblies have been removed prior to performing any repairs on the Sliding Handle itself. Refer to the system installation procedures in Chapter 3 for specific instructions regarding Coil Cord and Wire Rope removal.

1. Remove the M16 custom hex head cap screw (HHCS) and M16 Belleville washer from the top of the swivel assembly. Note the orientation of the Belleville washer, concave side down
2. Slide the swivel assembly off the top of the handle shaft, noting location of electrical connector. **Note:** Set aside the swivel sub-assembly with the PCBs facing upward to avoid damaging them.

Procedure S-1B. Swivel Sub-Assembly Replacement:

1. Slide the swivel assembly onto the top of the handle shaft, ensure PCB tabs align to the slots in the cast Housing Sub-Assembly.
2. Install the M16 custom hex head cap screw (HHCS) and M16 Belleville washer (concave side down) onto the top of the handle shaft.

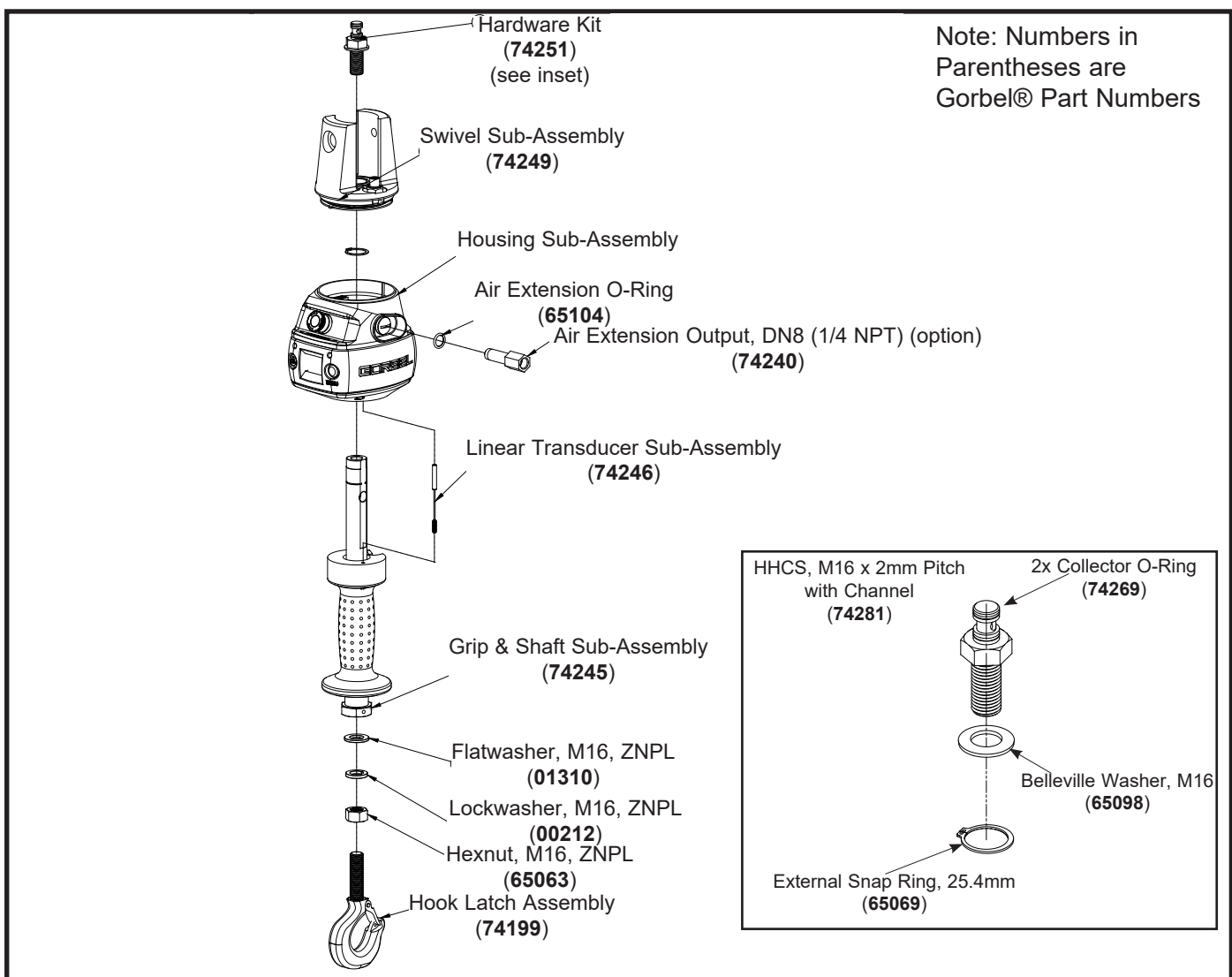

Diagram S-1. *In-Line Slide Handle Swivel Sub-Assembly Removal and Replacement.*

Procedure S-2A. Remote Mount Cap Sub-Assembly Removal

Note: This procedure assumes the handle has already been removed from a remote mount bracket or similar mounting device.

1. Remove M16 hex head cap screw (HHCS), flatwasher and lockwasher from the top of the handle assembly.
2. Slide the remote mount cap off the handle shaft. Note the orientation of the internal electrical connector located below the remote mount cap.

Procedure S-2B. Remote Mount Cap Sub-Assembly Replacement

1. Slide the remote mount cap onto the handle shaft. Note the orientation of the internal electrical connector located below the remote mount cap.
2. Position the handle assembly into the remote mount bracket (if applicable) and install M16 hex head cap screw (HHCS), flatwasher and lockwasher onto the top of the handle assembly.

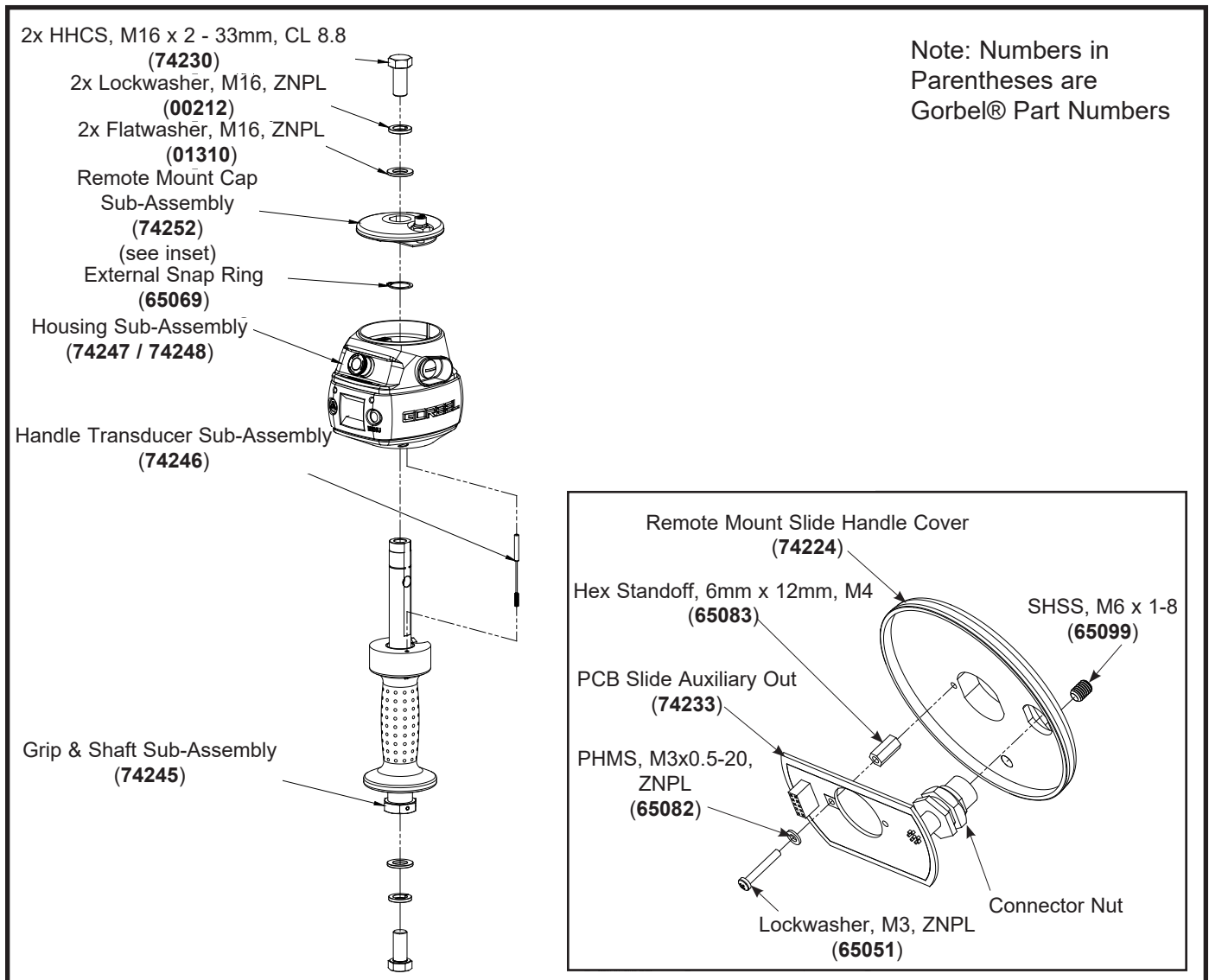

Diagram S-2. Remote Mounted Sliding Handle Remote Mount Cap Sub-Assembly Removal and Replacement

Procedure S-3A. Housing Sub-Assembly Disassembly

1. Remove the swivel sub-assembly or remote mount cap sub-assembly. Refer to Procedure S-1A or S-2A accordingly.
2. Remove the housing sub-assembly. Refer to Procedure S-3A.
3. Remove (4) M5 socket head cap screws (SHCS) and M5 flatwashers.
4. Separate the handle top sub-assembly from the handle bottom. Use caution, the ribbon cable, Operator Present Sensor, and ground wire will still be connected.
5. All the sub-assembly internal components can be removed or replaced if necessary; use the exploded view drawings as a reference.

Procedure S-3B. Housing Sub-Assembly Reassembly

1. All the sub-assembly internal components can be removed or replaced if necessary; use the exploded view drawings as a reference.
2. Once all the internal components have been positioned properly, slide the handle bumper in place on the handle bottom and join the handle top sub-assembly with the handle bottom. Make sure the ribbon cable, Operator Present Sensor, and ground wire are connected properly.
3. Install the (4) M5 socket head cap screws (SHCS) and M5 flatwashers.
4. Install the housing sub-assembly and swivel or remote cap sub-assemblies as required. Refer to Procedures S-3B and S-1B or S-2B.

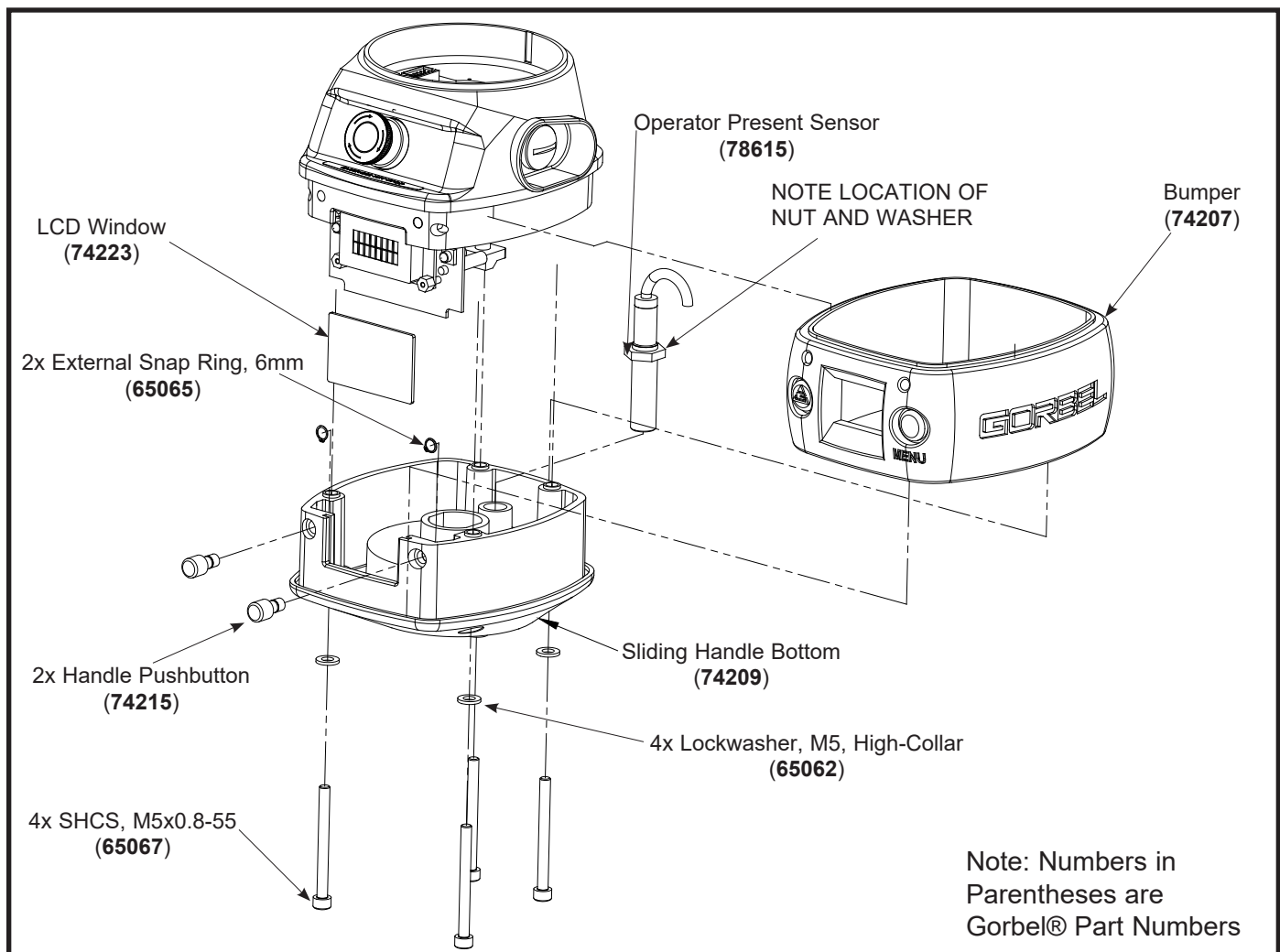

Diagram S-3a. Housing Sub-Assembly Assembly and Disassembly.

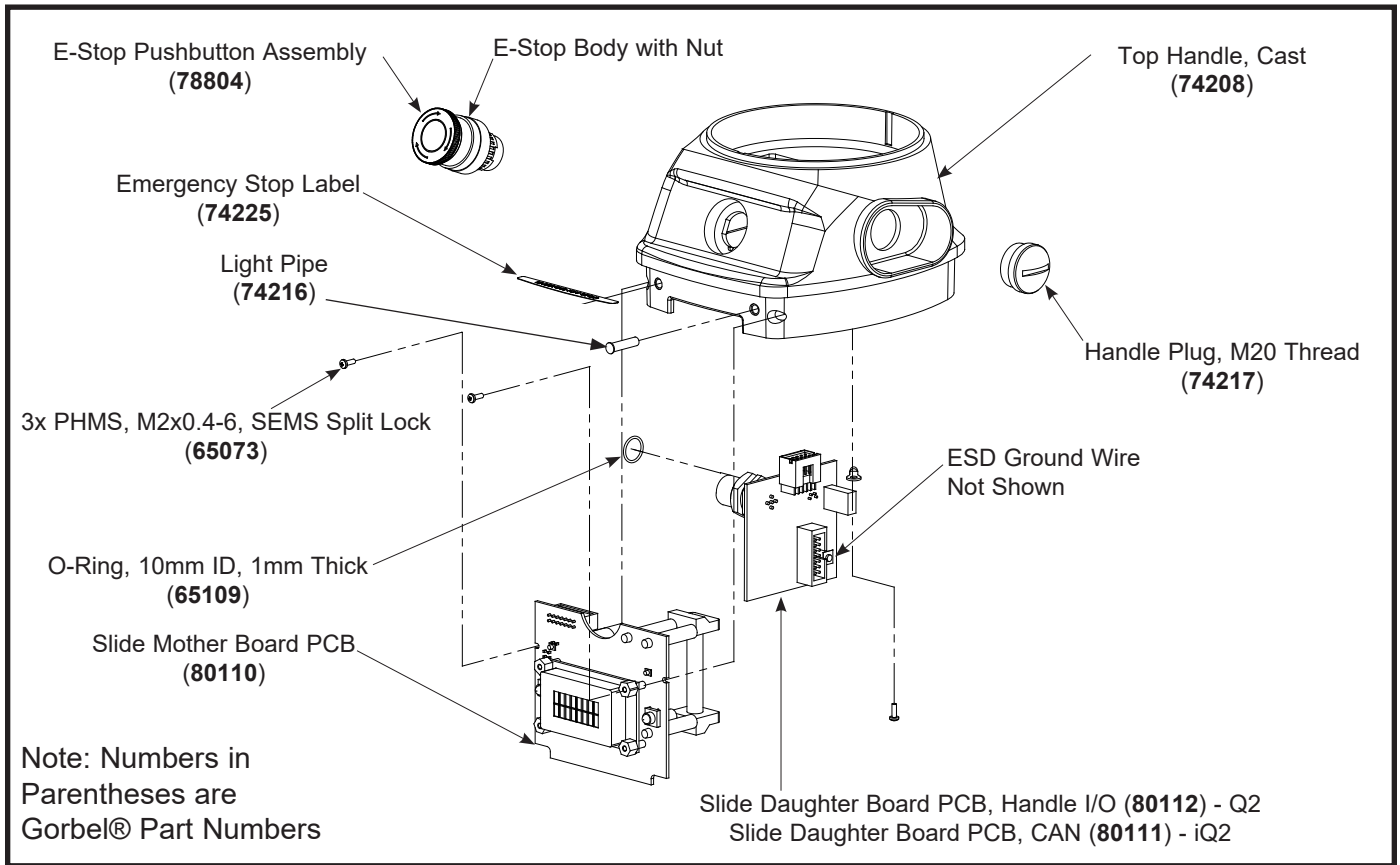

Diagram S-3b. Housing Sub-Assembly Components Assembly and Disassembly

Procedure S-4A. Handle Grip and Shaft Assembly Disassembly

1. Remove the swivel or remote mount cap sub-assembly. Refer to Procedure S-1A or S-2A.
2. Remove the housing sub-assembly. Refer to Procedure S-3A.
3. Remove the spring pin from the hex jam nut and handle shaft.
4. Remove the hex jam nut from the handle shaft.
5. Slide the spring sleeve down off the bottom portion of the handle shaft.
6. Slide the first bearing sleeve down off the bottom portion of the handle shaft.
7. Slide the compression spring down off the bottom portion of the handle shaft.
8. Slide the second bearing sleeve down off the bottom portion of the handle shaft.
9. Slide the grip assembly down off the bottom portion of the handle shaft.

Note: There are a total of (12) ball bearings seated in (3) separate grooves in the handle shaft. These are normally coated with grease and should remain in place however they can fall out if the amount of grease has decreased over time.

Procedure S-4B. Handle Grip and Shaft Assembly Reassembly

1. Install the grip assembly up from the bottom portion of the handle shaft and position the grip assembly so that the ball bearings can be installed into the grooves of the handle shaft from the top of the grip assembly.
2. Slide the second bearing sleeve up from the bottom portion of the handle shaft.
3. Slide the compression spring up from the bottom portion of the handle shaft.
4. Slide the first bearing sleeve up from the bottom portion of the handle shaft.
5. Slide the spring sleeve up from the bottom portion of the handle shaft.
6. Install the hex jam nut from the handle shaft.
7. Install the spring pin into the hex jam nut and handle shaft.
8. Replace the housing sub-assembly. Refer to Procedure S-3B.
9. Replace the swivel or remote mount cap sub-assembly. Refer to Procedure S-1B or S-2B.

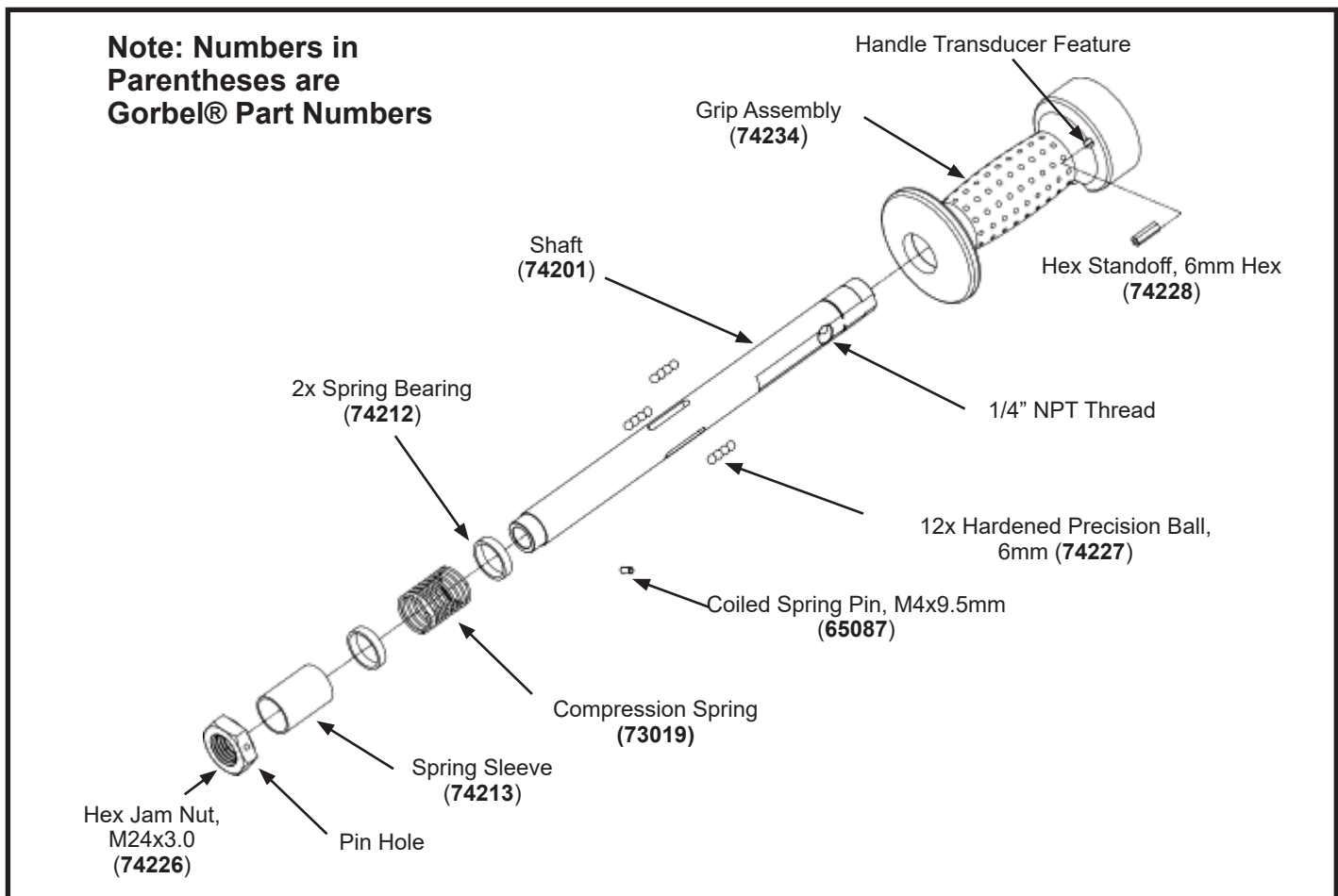
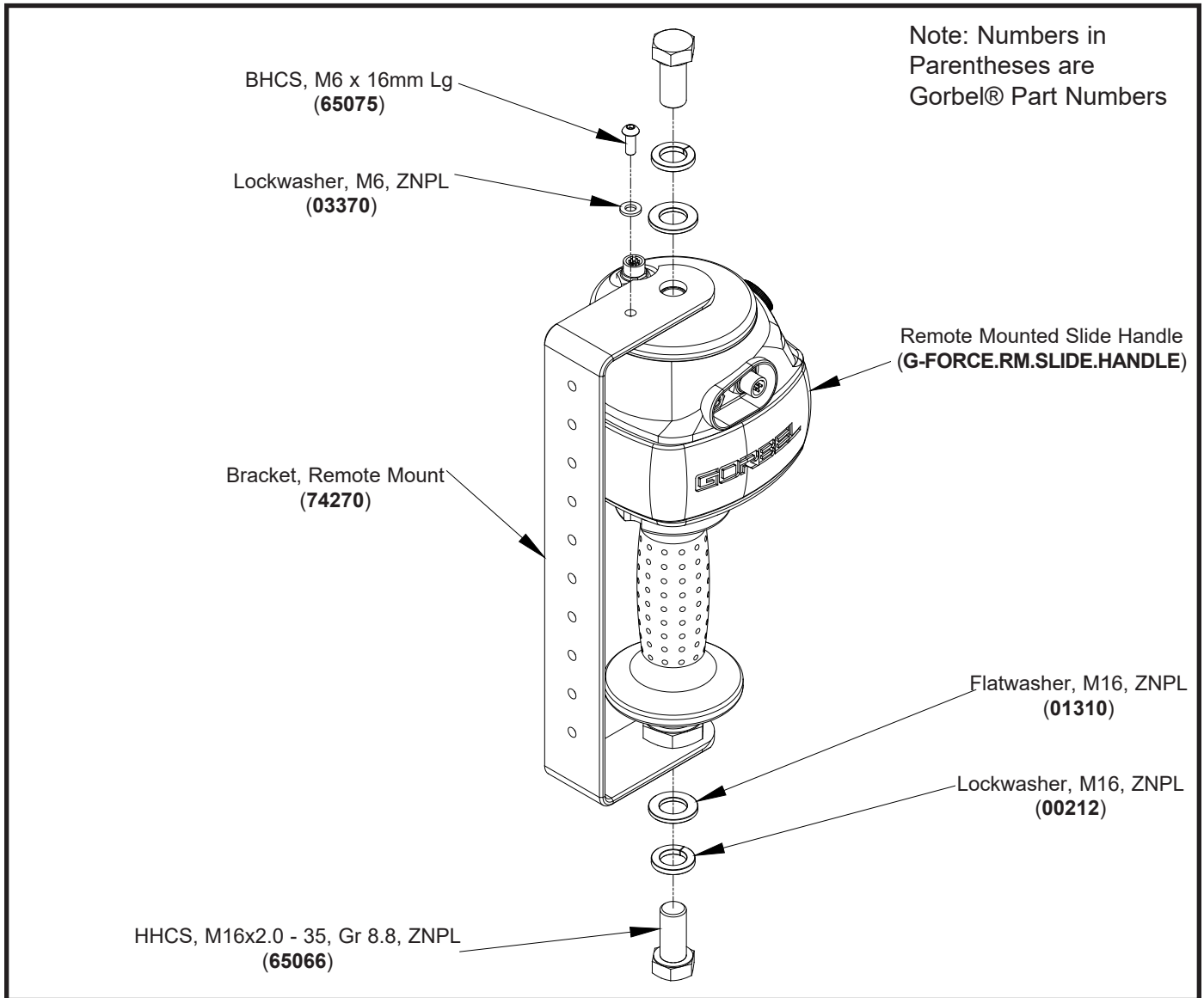
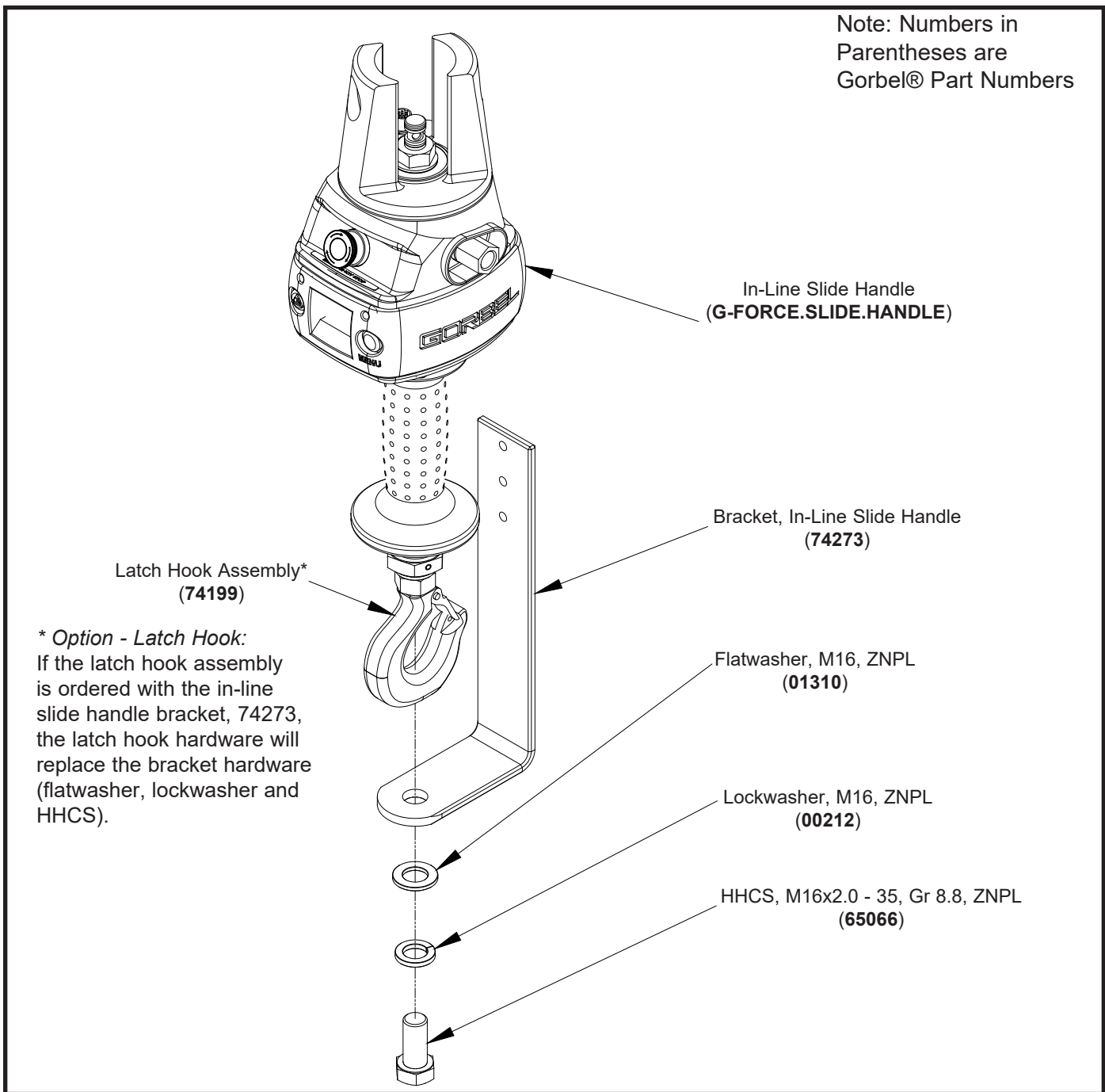

Diagram S-4. Handle Grip and Shaft Assembly and Disassembly.



Remote Mounted Slide Handle Bracket.

Note: Bracket Assembly with Hardware P/N 74350



In-Line Slide Handle Control Bracket.

Note: Bracket Assembly with Hardware P/N 74351

| Item | P/N | Description |
|------|-------|--------------------------------|
| 1 | 74271 | Bracket, Auxiliary Controls |
| 2 | 74272 | Bracket, Block Mount |
| 3 | 88816 | One Signal Pilot Valve, Metric |
| 4 | 88604 | Left Angled Lever (not shown) |
| 5 | 88605 | Right Angled Lever |
| 6 | 88901 | Lever Shaft 38mm Long |
| 7 | 88501 | Lever Guard 40mm Wide |
| 8 | 65075 | BHCS, M6 x 16mm Lg |
| 9 | 65076 | BHCS, M6 x 10mm Lg |
| 10 | 65100 | HHCS, M6x1.0 - 20, ZNPL |
| 11 | 65060 | Flatwasher, M6, ZNPL |
| 12 | 03370 | Lockwasher, M6, ZNPL |
| 13 | 01764 | Hexnut, M6, ZNPL |

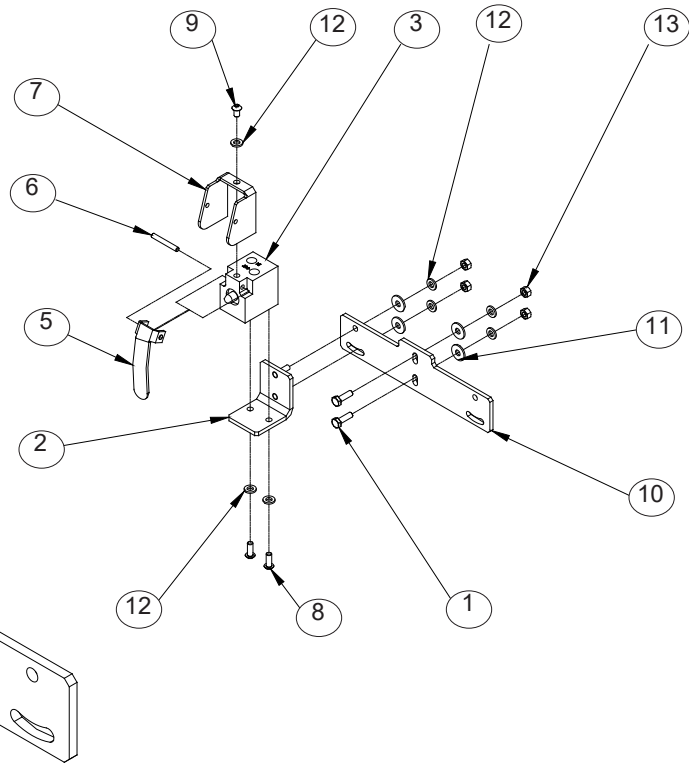

Single Auxiliary Control Pilot Valve Kit for Slide Handle.

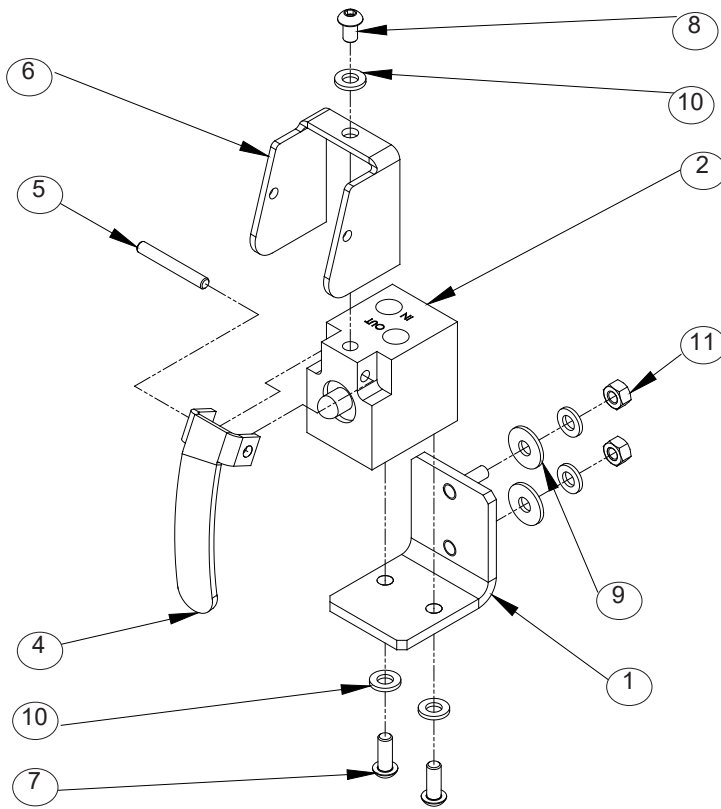

| Item | P/N | Description |
|------|-------|--------------------------------|
| 1 | 74272 | Bracket, Block Mount |
| 2 | 88816 | One Signal Pilot Valve, Metric |
| 3 | 88604 | Left Angled Lever (not shown) |
| 4 | 88605 | Right Angled Lever |
| 5 | 88901 | Lever Shaft 38mm Long |
| 6 | 88501 | Lever Guard 40mm Wide |
| 7 | 65075 | BHCS, M6 x 16mm Lg |
| 8 | 65076 | BHCS, M6 x 10mm Lg |
| 9 | 65060 | Flatwasher, M6, ZNPL |
| 10 | 03370 | Lockwasher, M6, ZNPL |
| 11 | 01764 | Hexnut, M6, ZNPL |

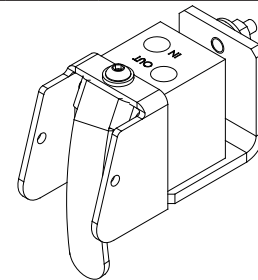

Auxiliary Control Pilot Valve Kit.

| Item | P/N | Description |
|------|---------|-------------------------------|
| 1 | 74271 | Bracket, Auxiliary Controls |
| 2 | 74272 | Bracket, Block Mount |
| 3 | 74330 | Electric Switch Block, Single |
| 4 | Ref BOM | Switch Body w/Roller Plunger |
| 5 | 65027 | SHCS, M4 x 20mm Lg |
| 6 | 65052 | Lockwasher, M4, ZNPL |
| 7 | 88604 | Left Angled Lever (not shown) |
| 8 | 88605 | Right Angled Lever |
| 9 | 88901 | Lever Shaft 38mm Long |
| 10 | 88501 | Lever Guard 40mm Wide |
| 11 | 65075 | BHCS, M6 x 16mm Lg |
| 12 | 65076 | BHCS, M6 x 10mm Lg |
| 13 | 65100 | HHCS, M6x1.0 - 20, ZNPL |
| 14 | 65060 | Flatwasher, M6, ZNPL |
| 15 | 03370 | Lockwasher, M6, ZNPL |
| 16 | 01764 | Hexnut, M6, ZNPL |

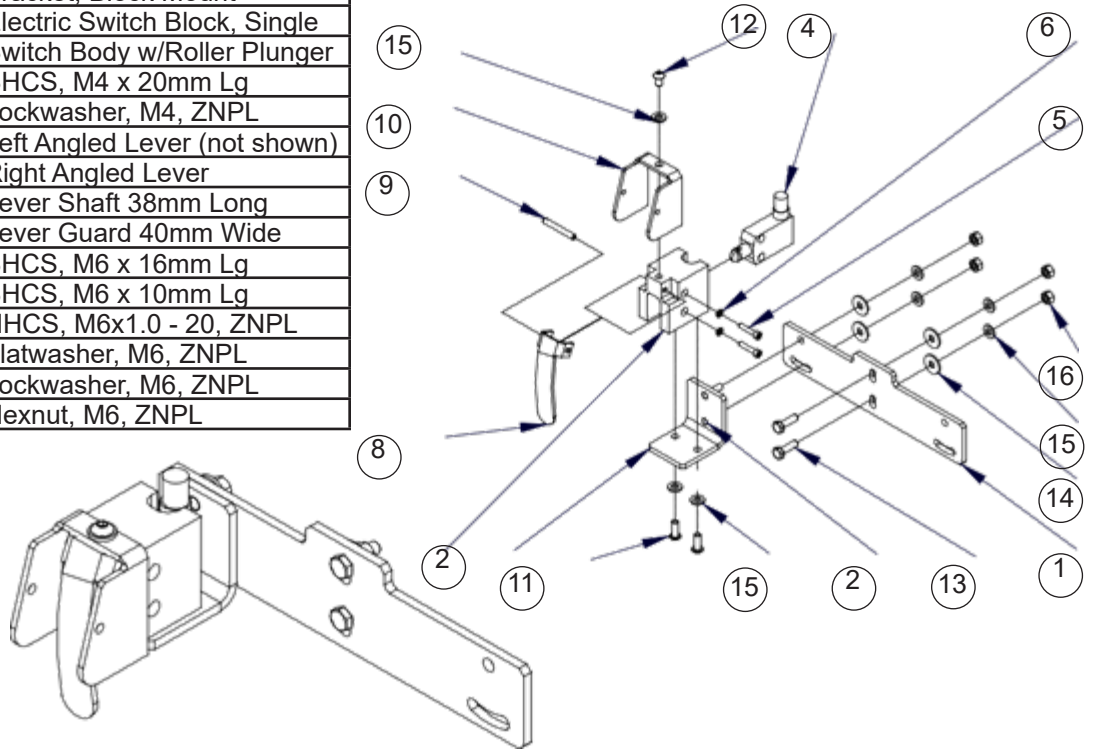

Auxiliary Electric Switch with Bracket

| Item | P/N | Description |
|------|---------|-------------------------------|
| 1 | 74272 | Bracket, Block Mount |
| 2 | 74330 | Electric Switch Block, Single |
| 3 | Ref BOM | Switch Body w/Roller Plunger |
| 4 | 65027 | SHCS, M4 x 20mm Lg |
| 5 | 65052 | Lockwasher, M4, ZNPL |
| 6 | 88604 | Left Angled Lever (not shown) |
| 7 | 88605 | Right Angled Lever |
| 8 | 88901 | Lever Shaft 38mm Long |
| 9 | 88501 | Lever Guard 40mm Wide |
| 10 | 65075 | BHCS, M6 x 16mm Lg |
| 11 | 65076 | BHCS, M6 x 10mm Lg |
| 12 | 65060 | Flatwasher, M6, ZNPL |
| 13 | 03370 | Lockwasher, M6, ZNPL |
| 14 | 01764 | Hexnut, M6, ZNPL |

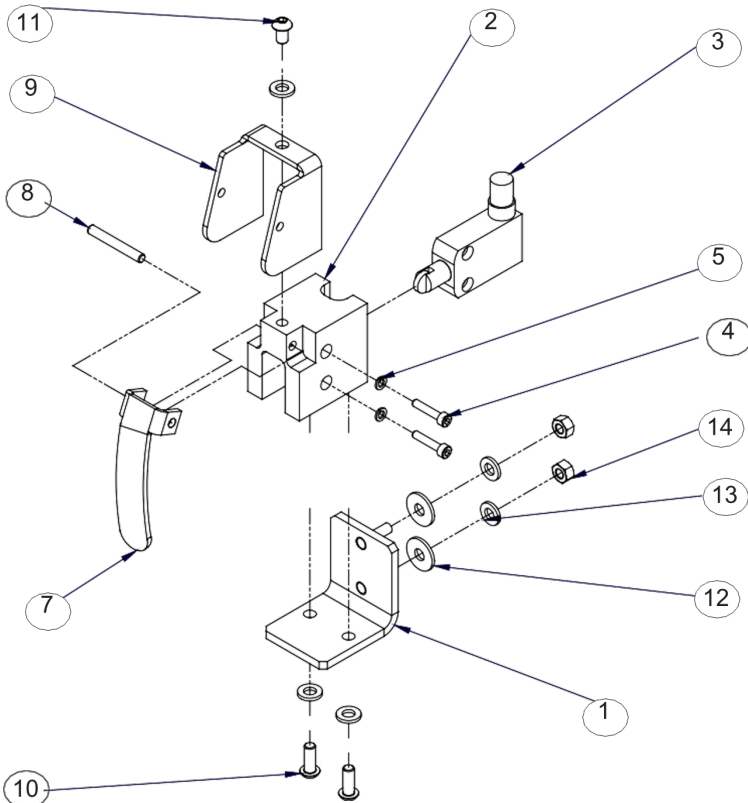

Single Electric Switch Assembly for Slide Handle

Removal & Replacement Procedures

PENDANT HANDLE

Note: The following procedures assume any electrical or support cables have been disconnected prior to performing any repairs on the Pendant Handle itself.

Procedure P-1A. Top & Side Guard Removal

1. Remove the (4) M6 button head cap screws (BHCS) and M6 lockwashers.
2. Slide the top guard off the top portion of the pendant handle.
3. Remove the (2) M6 button head cap screws (BHCS) and M6 lockwashers.
4. Remove the (2) side guards off each side of the pendant handle.

Procedure P-1B. Top & Side Guard Replacement

1. Position the top guard on the top portion of the pendant handle.
2. Install the (4) M6 button head cap screws (BHCS) and M6 lockwashers.
3. Position the (2) side guards on each side of the pendant handle.
4. Install the (2) M6 button head cap screws (BHCS) and M6 lockwashers on each side of the pendant handle.

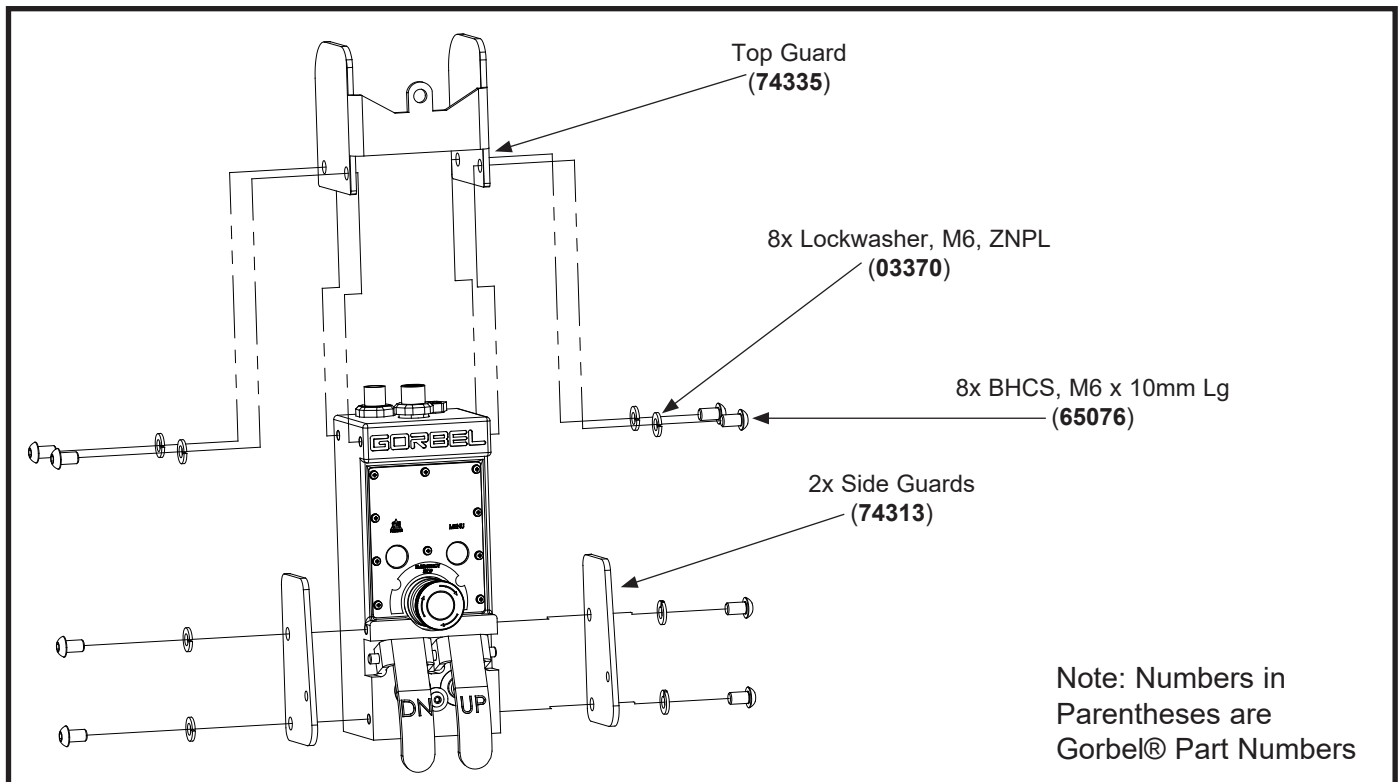

Diagram P-1. Top & Side Guard Removal and Replacement

Procedure P-2A. Lever Removal

1. Remove either side guard. Refer to Procedure P-1A.
2. Remove the lever shaft.
3. Remove both levers from the pendant handle.

Procedure P-2B. Lever Replacement

1. Position both levers on the pendant handle.
2. Install the lever shaft.
3. Install the side guard. Refer to Procedure P-1B.

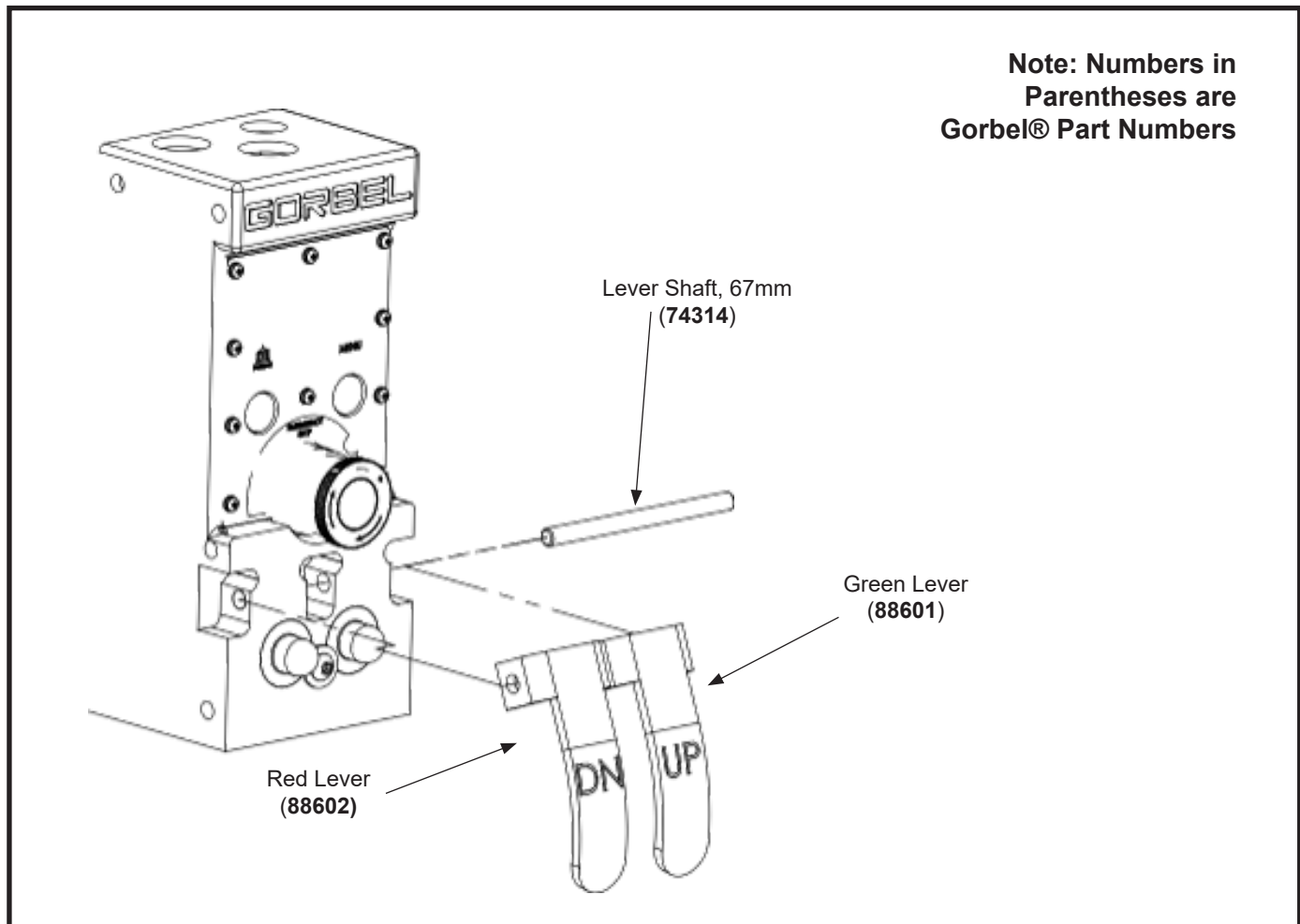

Diagram P-2. Lever Removal and Replacement.

Procedure P-3A. Handle Base Bracket Removal

1. Disconnect handle base bracket from clamp collar or tooling if necessary.
2. Remove (2) M6 button head cap screws (BHCS) and M6 lockwashers.

Procedure P-3B. Handle Base Bracket Replacement

1. Install (2) M6 button head cap screws (BHCS) and M6 lockwashers.
2. Reattach the handle base bracket to clamp collar or tooling if necessary.

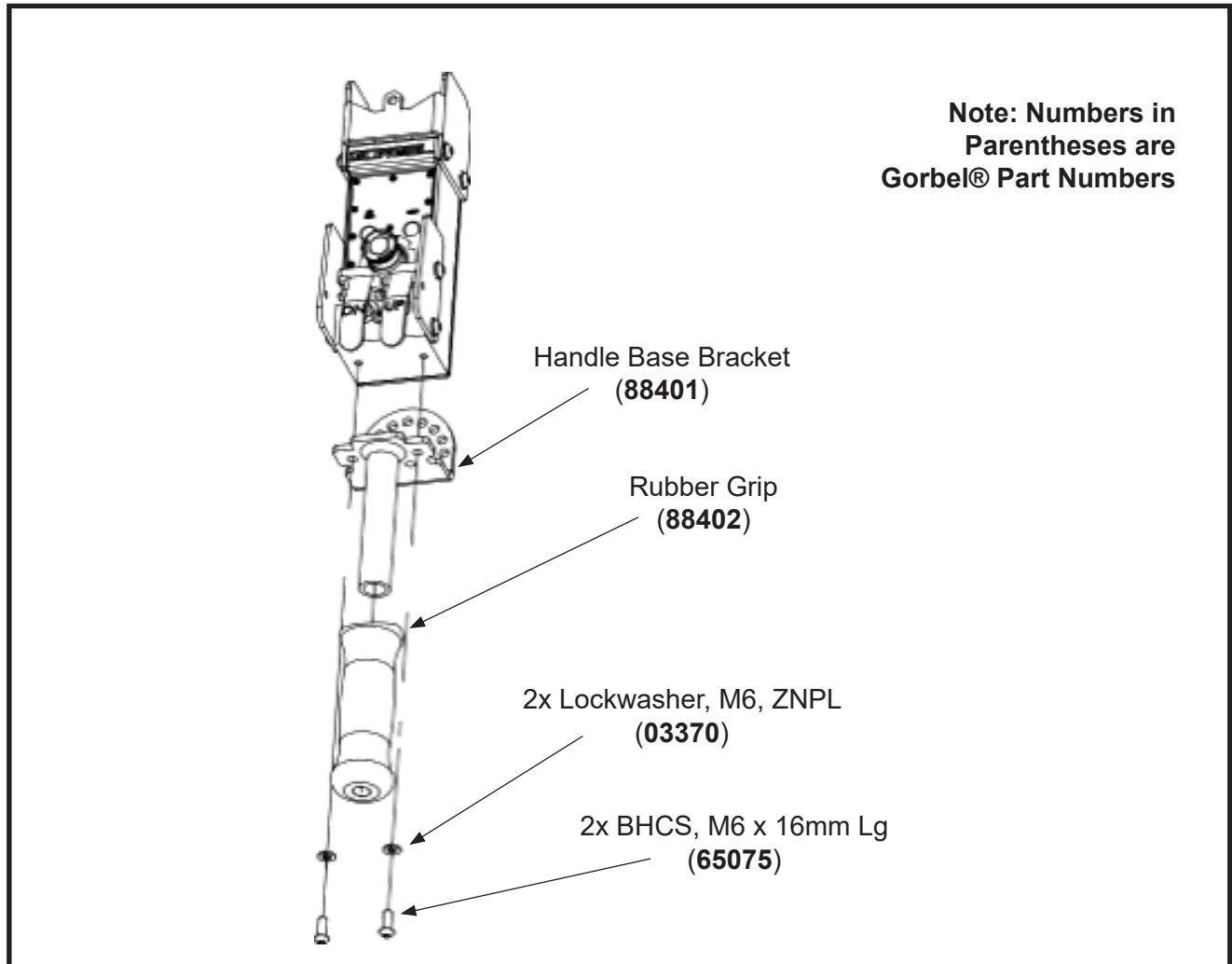

Diagram P-3. *Handle Base Bracket Removal and Replacement.*

Procedure P-4A. Rear Cover Removal

1. Remove handle base bracket. Refer to Procedure P-3A.
2. Remove the (6) M3 button head cap screws (BHCS) and M3 lockwashers that secure the rear cover.
3. Remove rear cover and rear cover gasket.

Procedure P-4B. Rear Cover Replacement

1. Position rear cover gasket and rear cover on pendant handle assembly.
2. Install the (6) M3 button head cap screws (BHCS) and M3 lockwashers that secure the rear cover.
3. Install handle base bracket. Refer to Procedure P-3B.

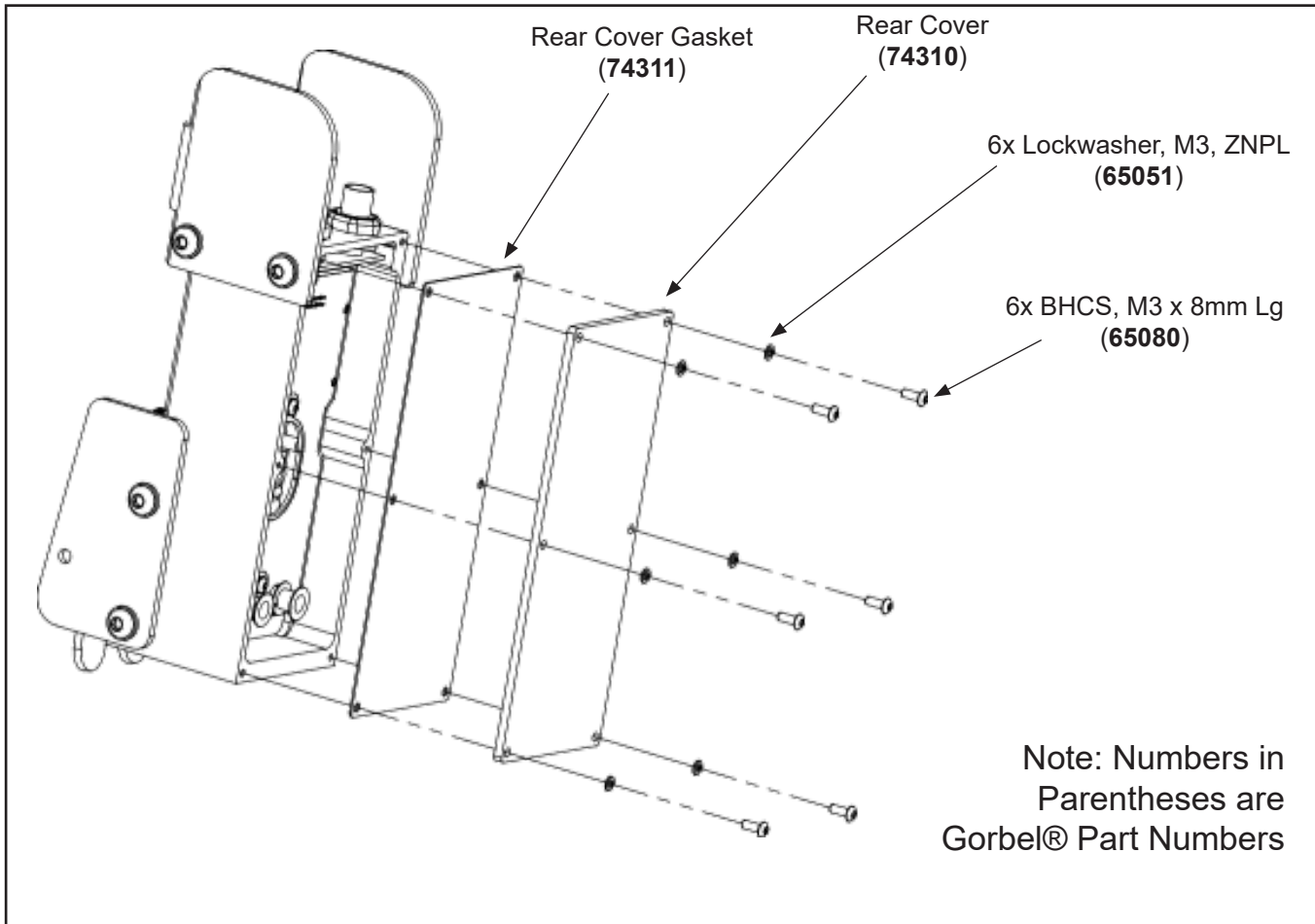

Diagram P-4. Rear Cover Removal and Replacement.

Procedure P-5A. Pendant Mother and Pendant Daughter Board Removal

1. Remove handle base bracket. Refer to Procedure P-3A.
2. Remove the rear cover. Refer to Procedure P-4A.
3. Remove the **external nuts on the electrical connectors from the pendant daughter board.**
4. Remove the (2) M3 button head cap screws (BHCS) and M3 starwashers from the pendant mother board.
5. Slide the pendant mother board down to disconnect it from the daughter board and remove them out from the pendant handle body.

Procedure P-5B. Pendant Mother and Pendant Daughter Board Replacement

1. Insert the daughter board into the machined holes in the pendant handle body then slide the pendant mother board into the daughter board.
2. Install the (2) M3 button head cap screws (BHCS) and M3 starwashers to secure the pendant mother board inside the pendant handle body. **Do NOT fully tighten these screws until proper clearance from each Button Plunger has been verified by actuating each Button Lever.**
3. Install the **external nuts on the electrical connectors on the pendant daughter board.**
4. Install the rear cover and rear cover gasket. Refer to Procedure P-4B.
5. Install the handle base bracket. Refer to Procedure P-3B.

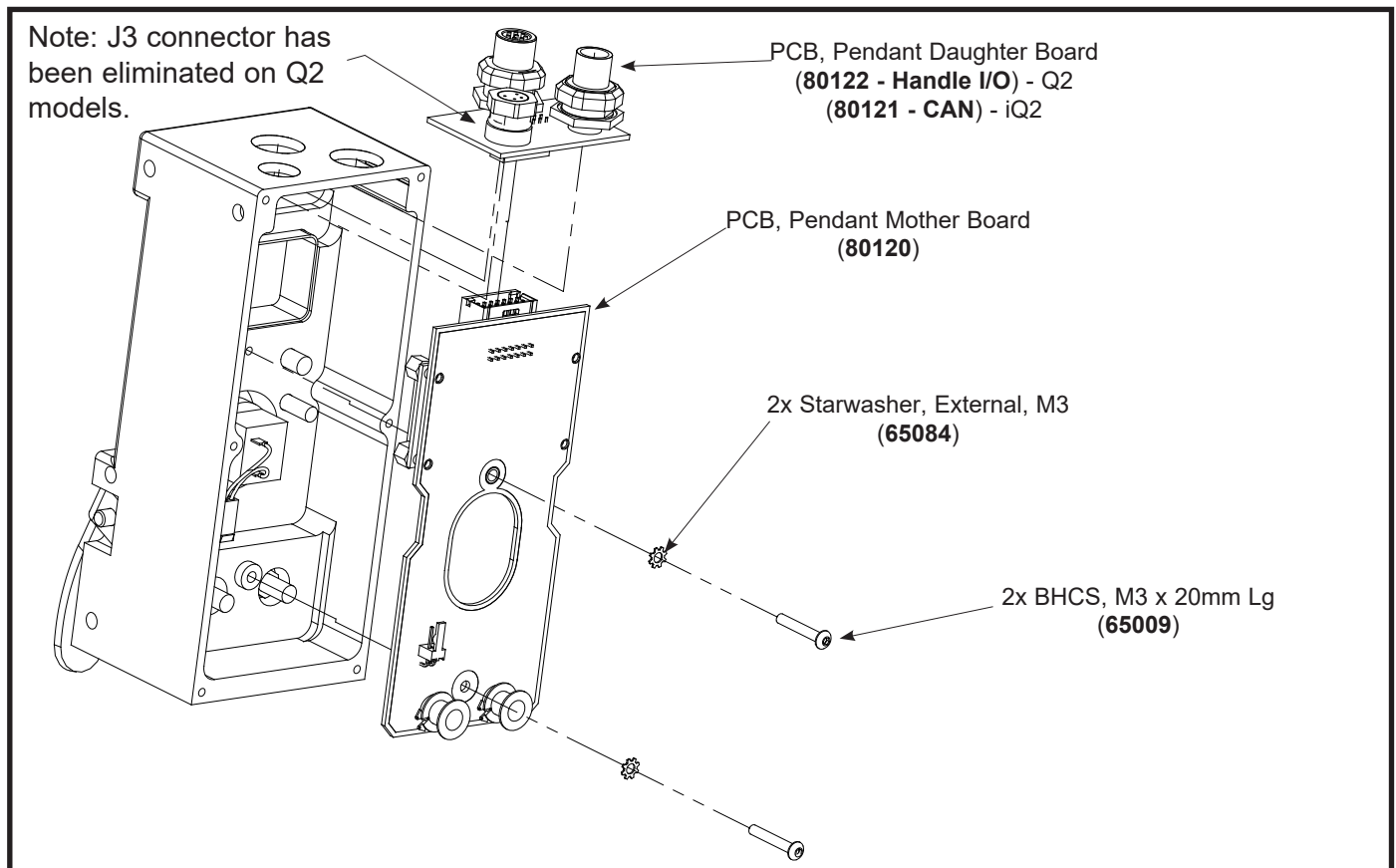

Diagram P-5. Pendant Mother and Daughter Board Removal and Replacement.

Procedure P-6A. Plunger Assembly Removal

1. Remove either side guard. Refer to Procedure P-1A.
2. Remove both levers and the lever shaft. Refer to Procedure P-2A.
3. Remove the M4 button head cap screw (BHCS) and M4 large OD washer.
4. Slide both plunger assemblies out of pendant handle housing.
5. Remove the plunger springs from plunger assemblies.
6. Remove the plunger tips from plunger assemblies.

Procedure P-6B. Plunger Assembly Replacement

1. Install the plunger tips into the plunger assemblies.
2. Install the plunger springs into the pendant handle housing.
3. Install both plunger assemblies into the pendant handle housing.
4. Install the M4 button head cap screw (BHCS) and M4 large OD washer to secure the plunger assemblies in the pendant handle housing.
5. Install both levers and the lever shaft. Refer to Procedure P-2B.
6. Install the side guard. Refer to Procedure P-1B.

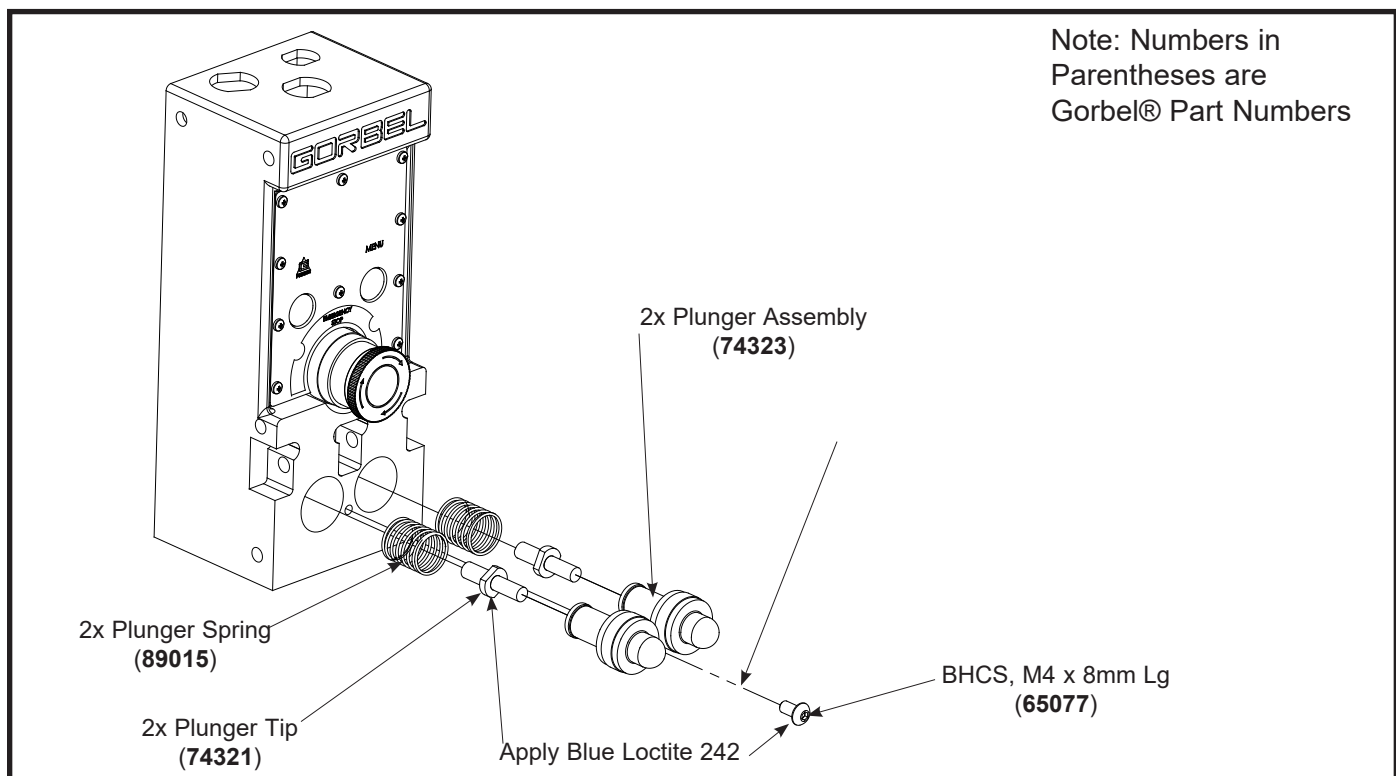

Diagram P-6. Plunger Assembly Removal and Replacement.

Procedure P-7A. E-Stop Assembly and Pushbutton Removal

1. Remove the handle base bracket and backplate & seal. Refer to Procedures P-3A and P-4A.
2. Slide the metal E-stop latch (under the yellow latch cover) inside the housing to release the E-stop pushbutton from the pendant handle housing.

Note: The E-stop button assembly is removed and installed from the inside of the housing. There are two parts that make up the E-stop assembly. The switch part is disconnected from the inside first. The pushbutton is then held in place by a nut that needs to be removed from the inside.

Procedure P-7B. E-Stop Assembly and Pushbutton Replacement

1. Install the E-stop pushbutton into the pendant handle housing, and lock into place by sliding the metal E-Stop latch back (and secure yellow latch cover).
2. Install the backplate & seal and handle base bracket. Refer to Procedure P-3B and P-4B.

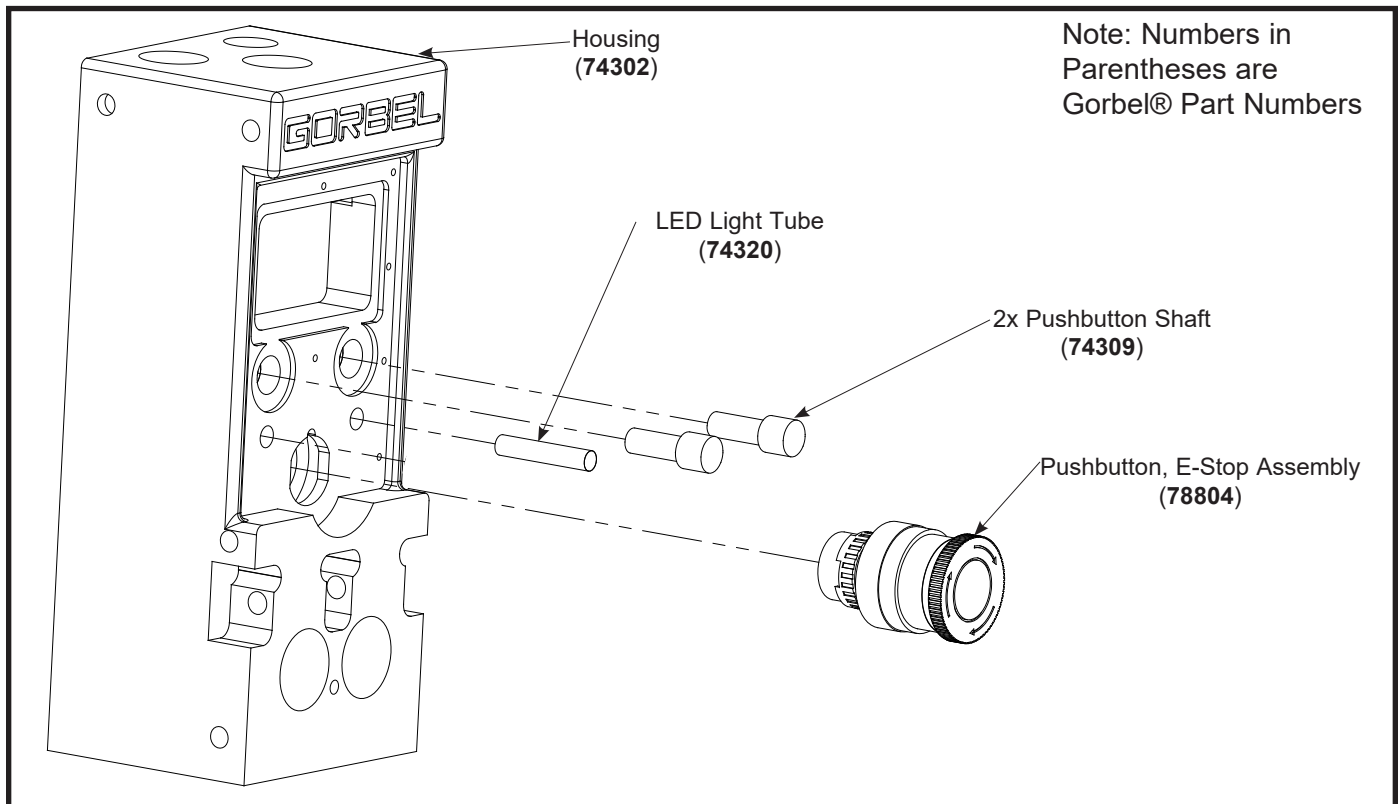
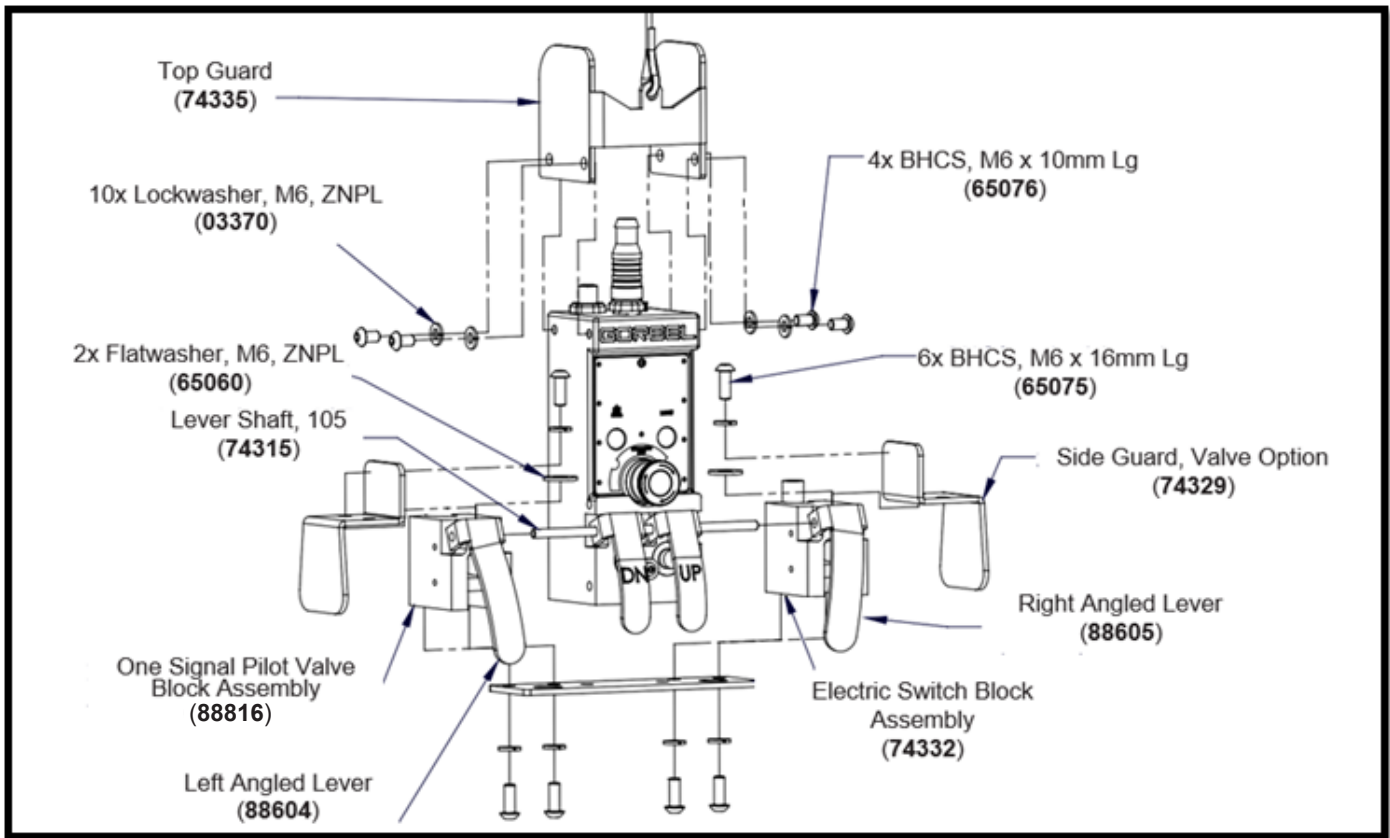

Diagram P-7. E-Stop Assembly, Pushbutton and Light Tube Removal and Replacement



Valve Left Side, Electric Switch Right Side.

Notes:

- The valve or electric switch can be used on either side of the pendant handle housing either separately or together.
- If using (a) single/both of the switch/valve block(s) then be sure to use either the Electric/Pneumatic Mounting Plate Left/Right (74317) or the Electric/Pneumatic Mounting Plate Both (74318).
- If using a single switch/valve block, then the standard side guard (74313) will be used opposite the block.

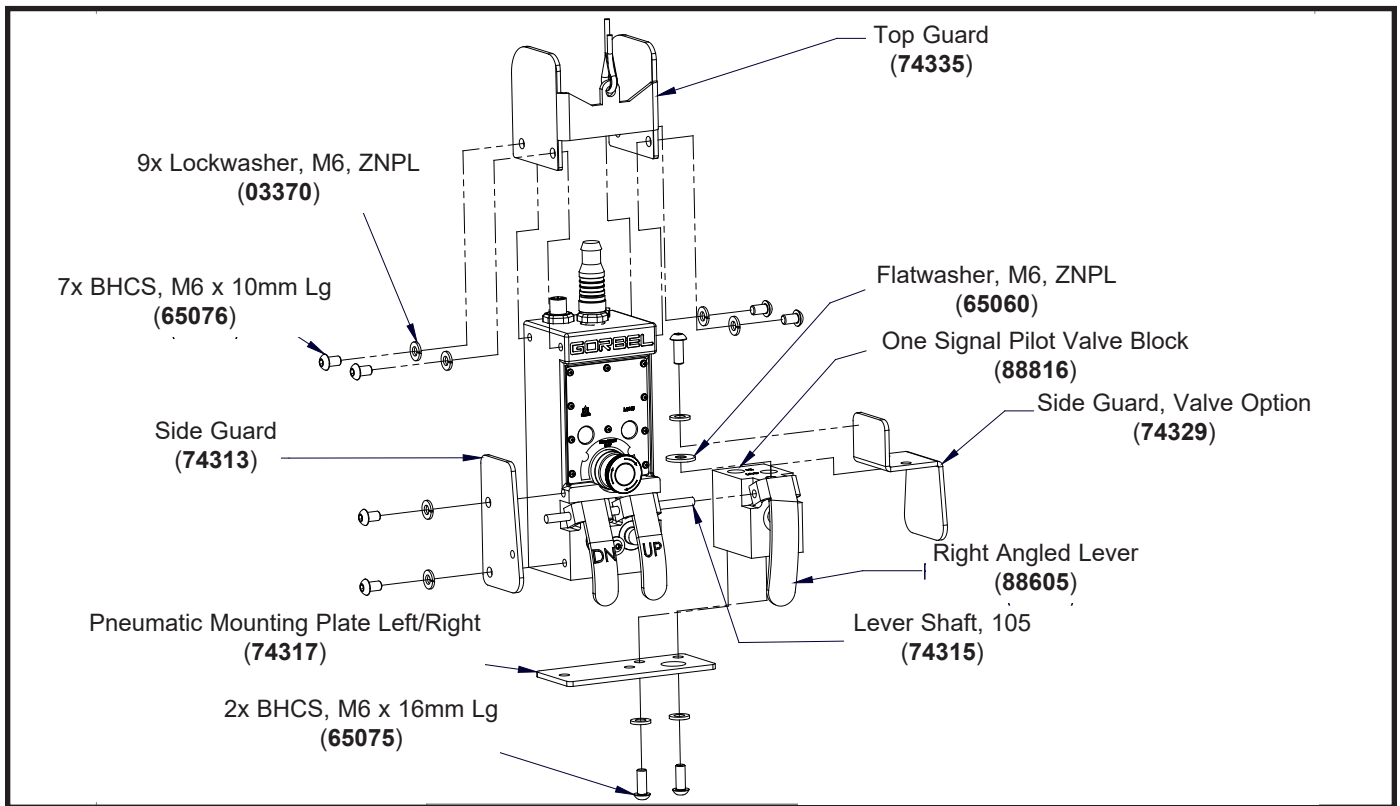

Single Valve Option - Right Side.

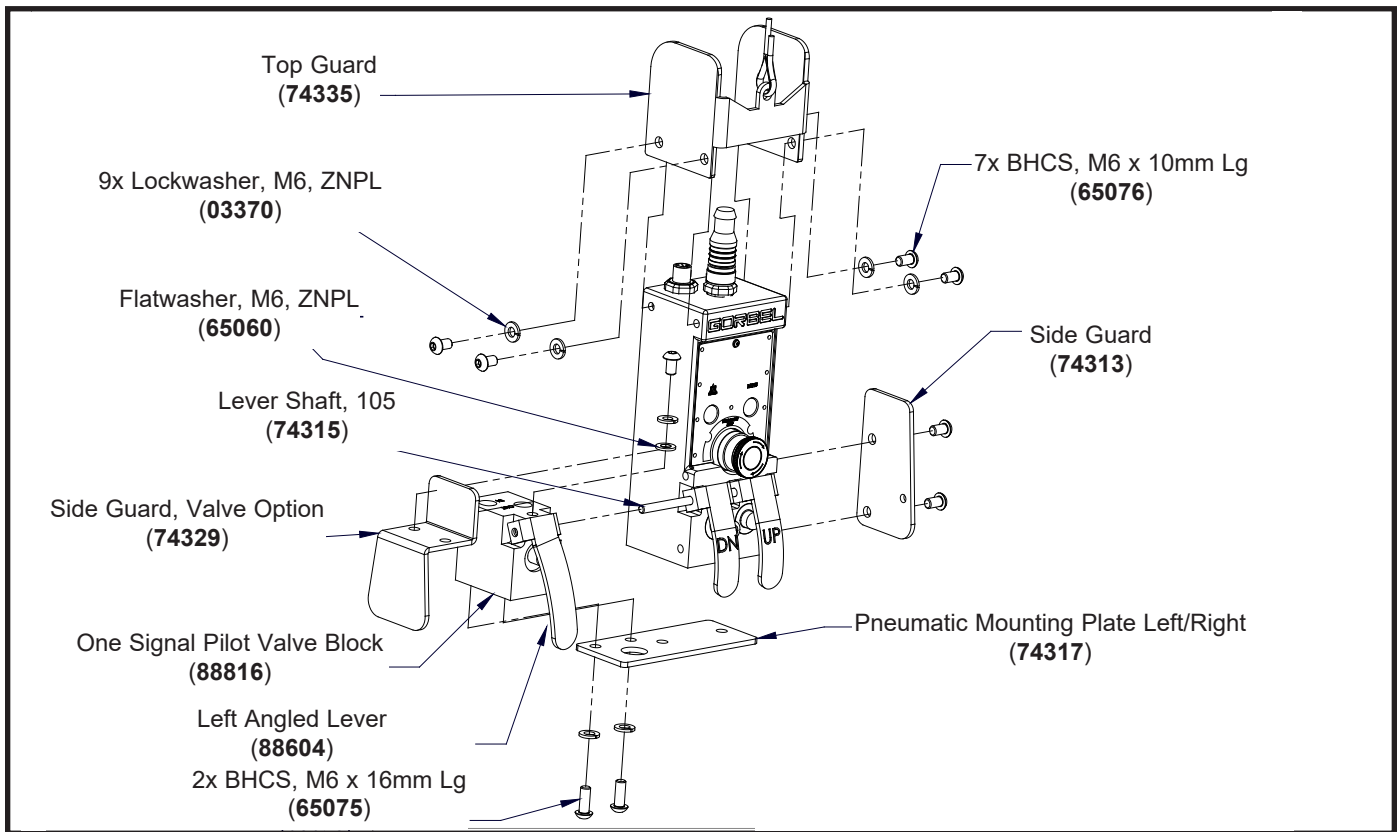

Single Valve Option - Left Side.

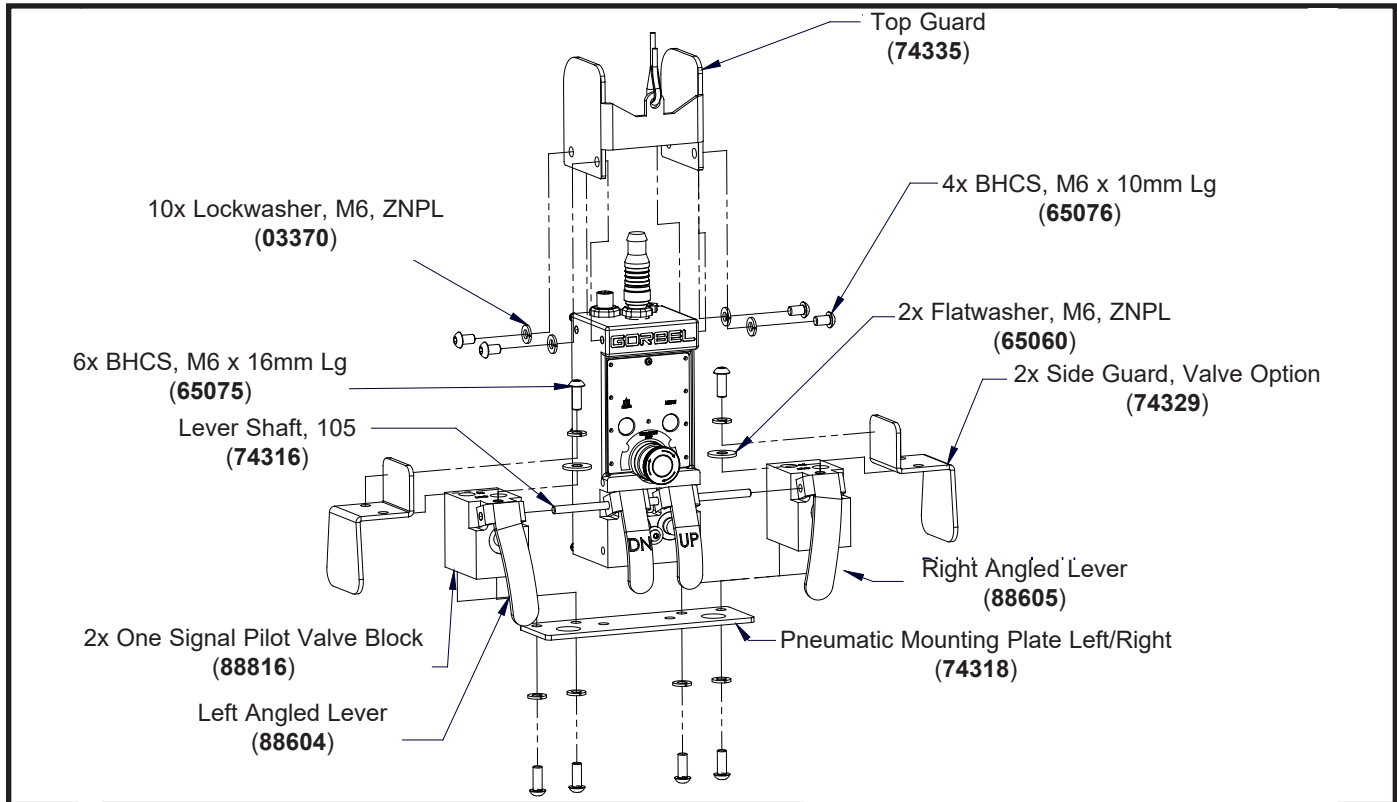

Single Valve Option - Right and Left Sides.

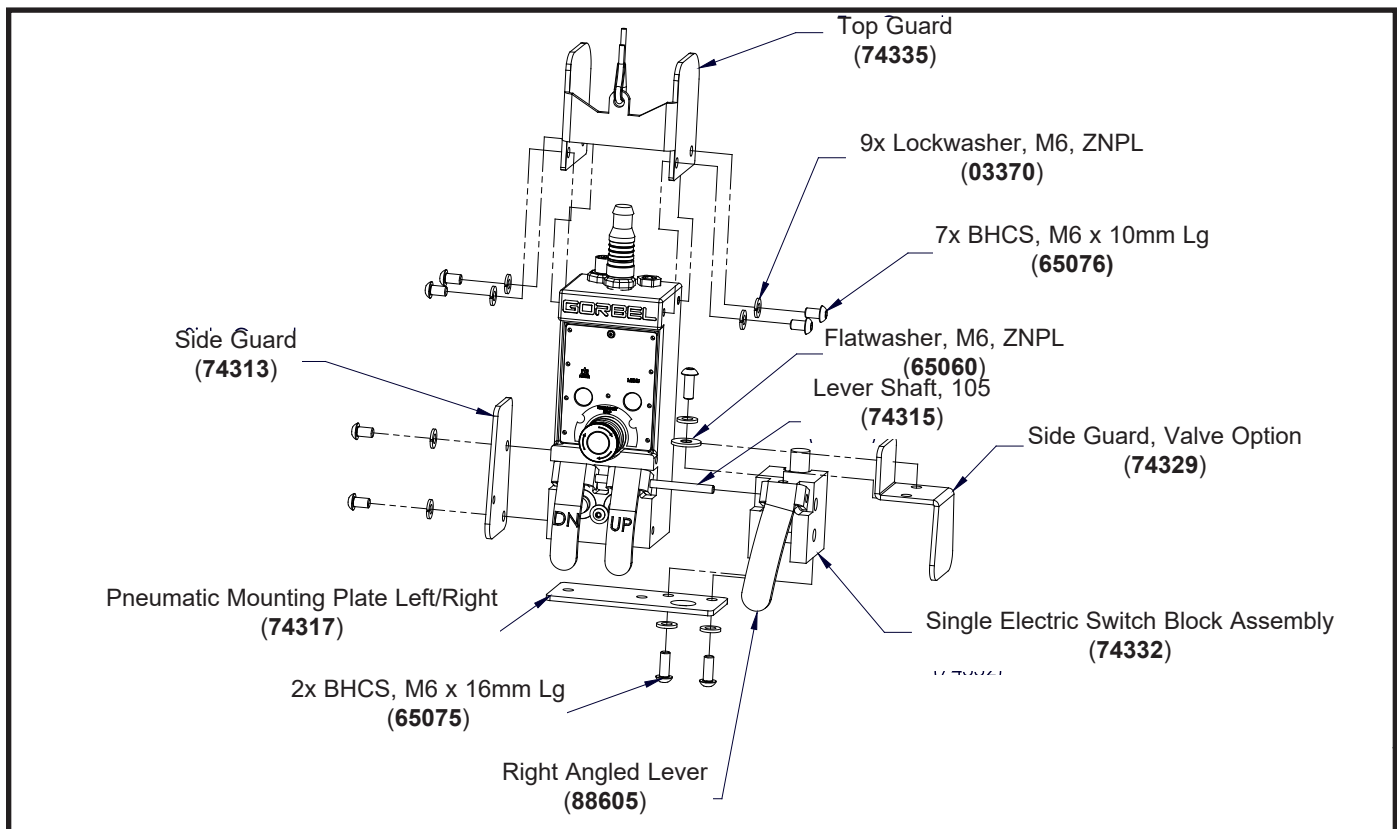

Electric Switch Options - Right Side.

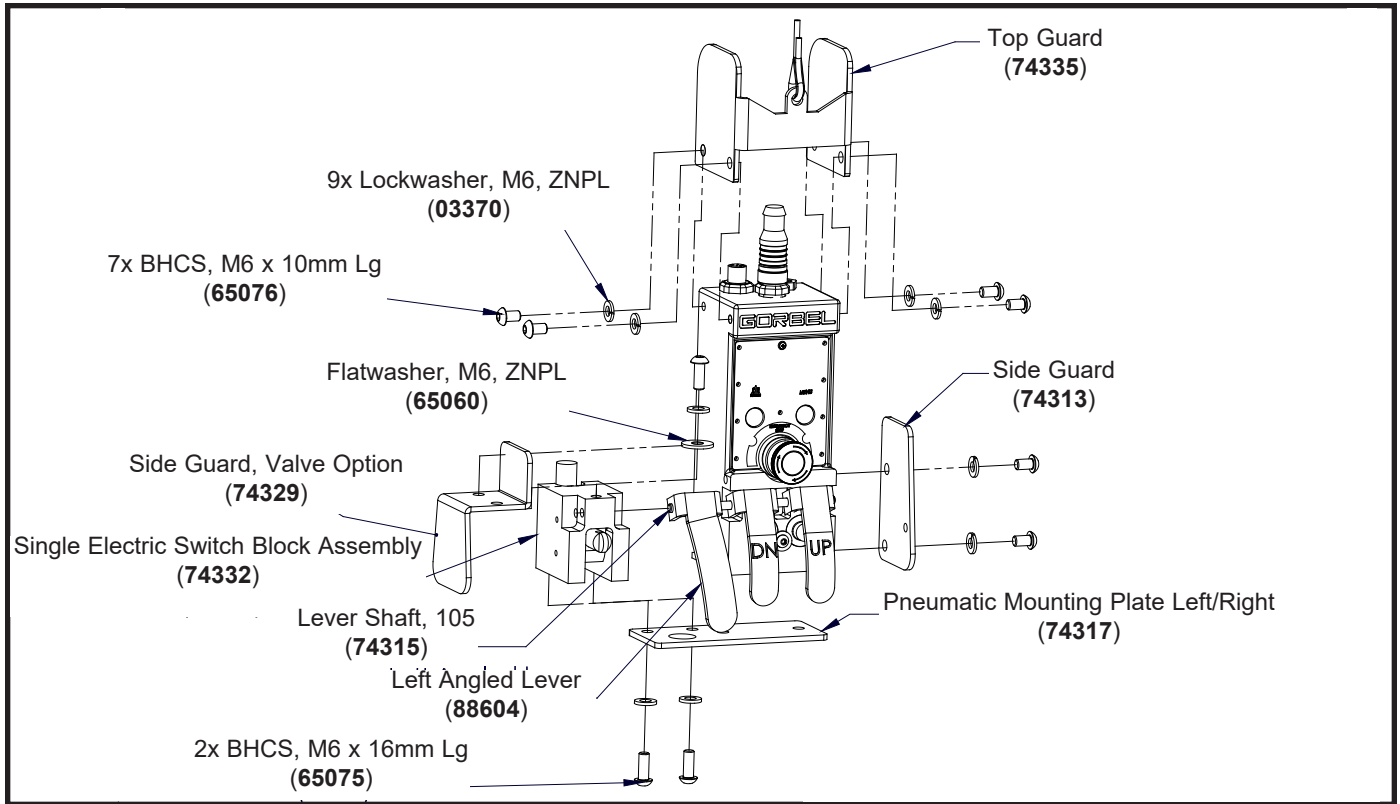

Electric Switch Option - Left Side.

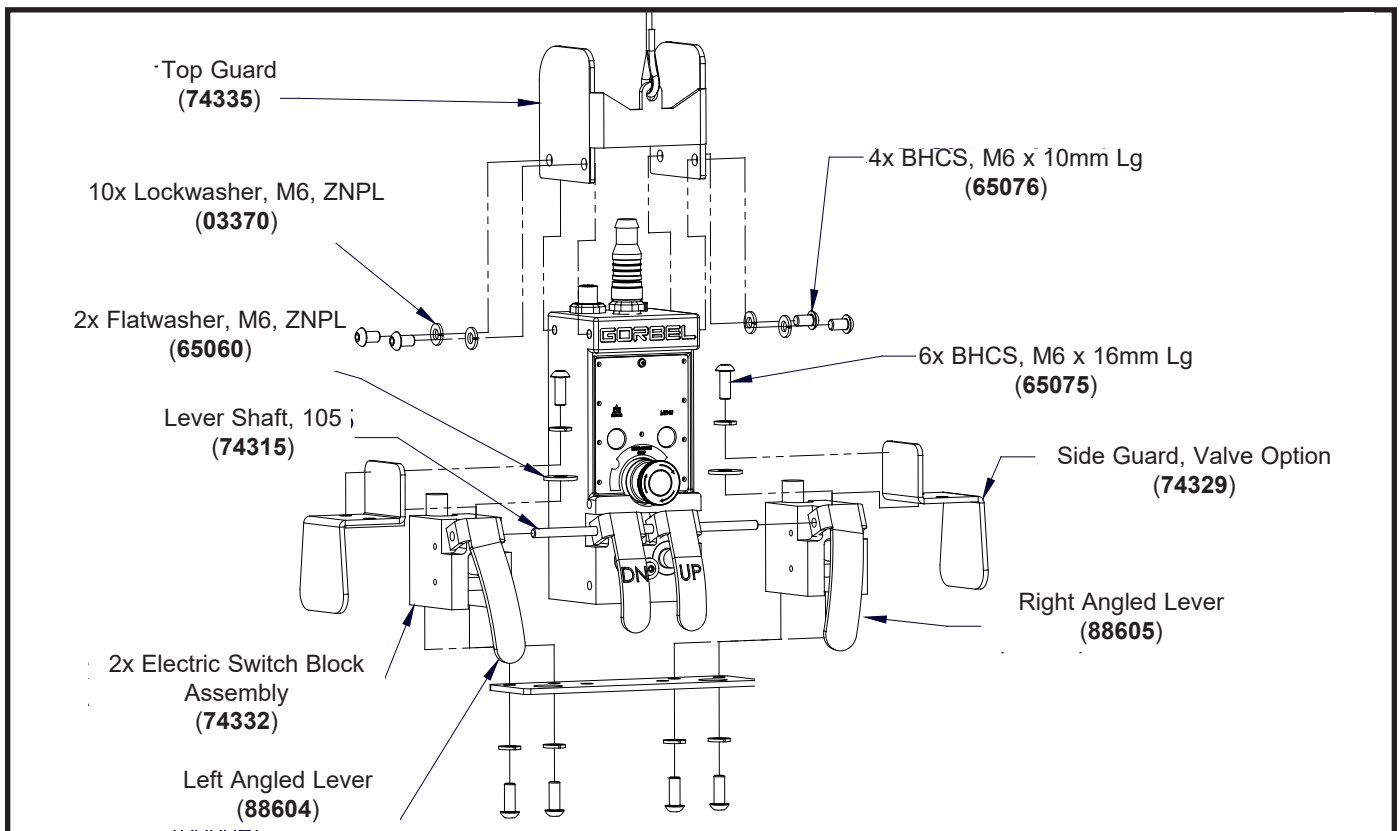

Electric Switch Option - Both Sides.

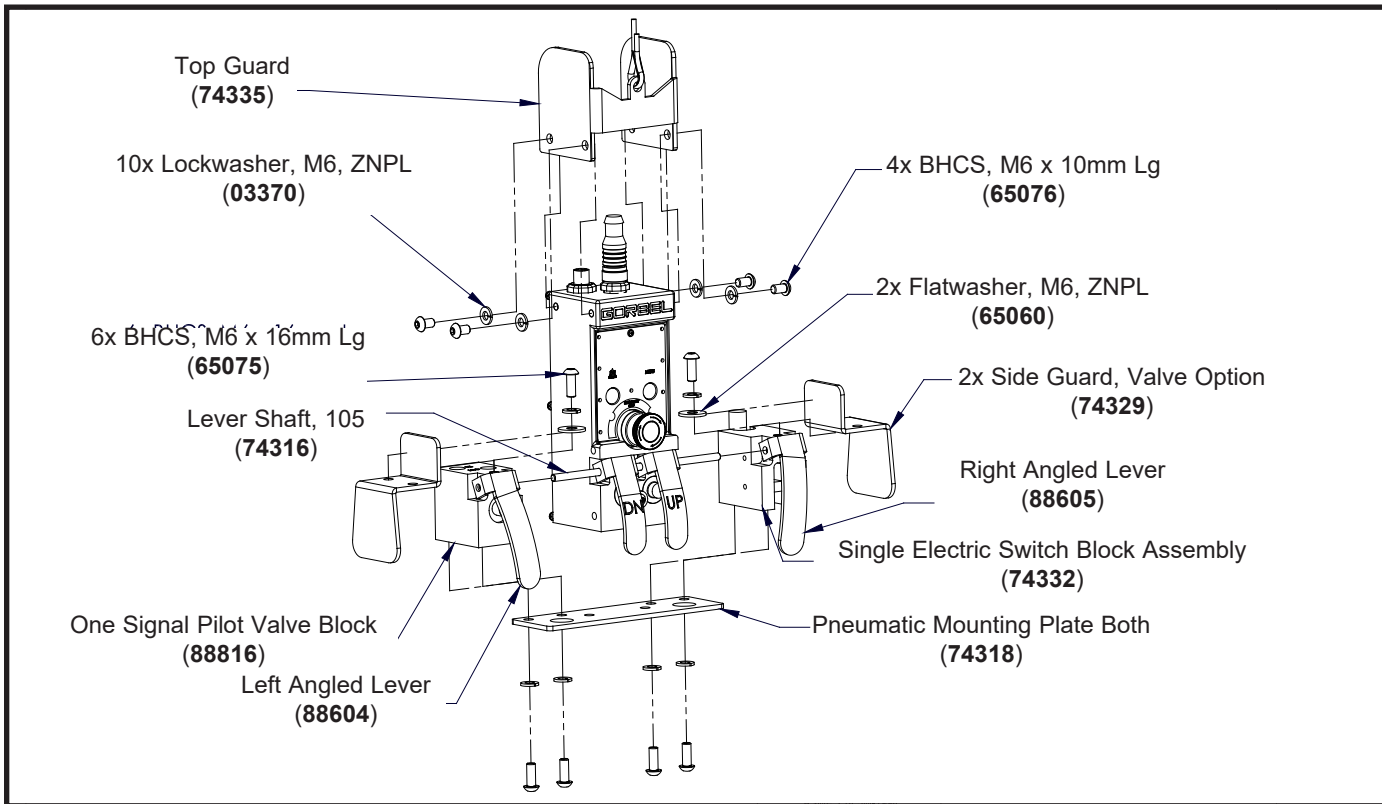

Electric Switch Right Side, Valve Left Side.

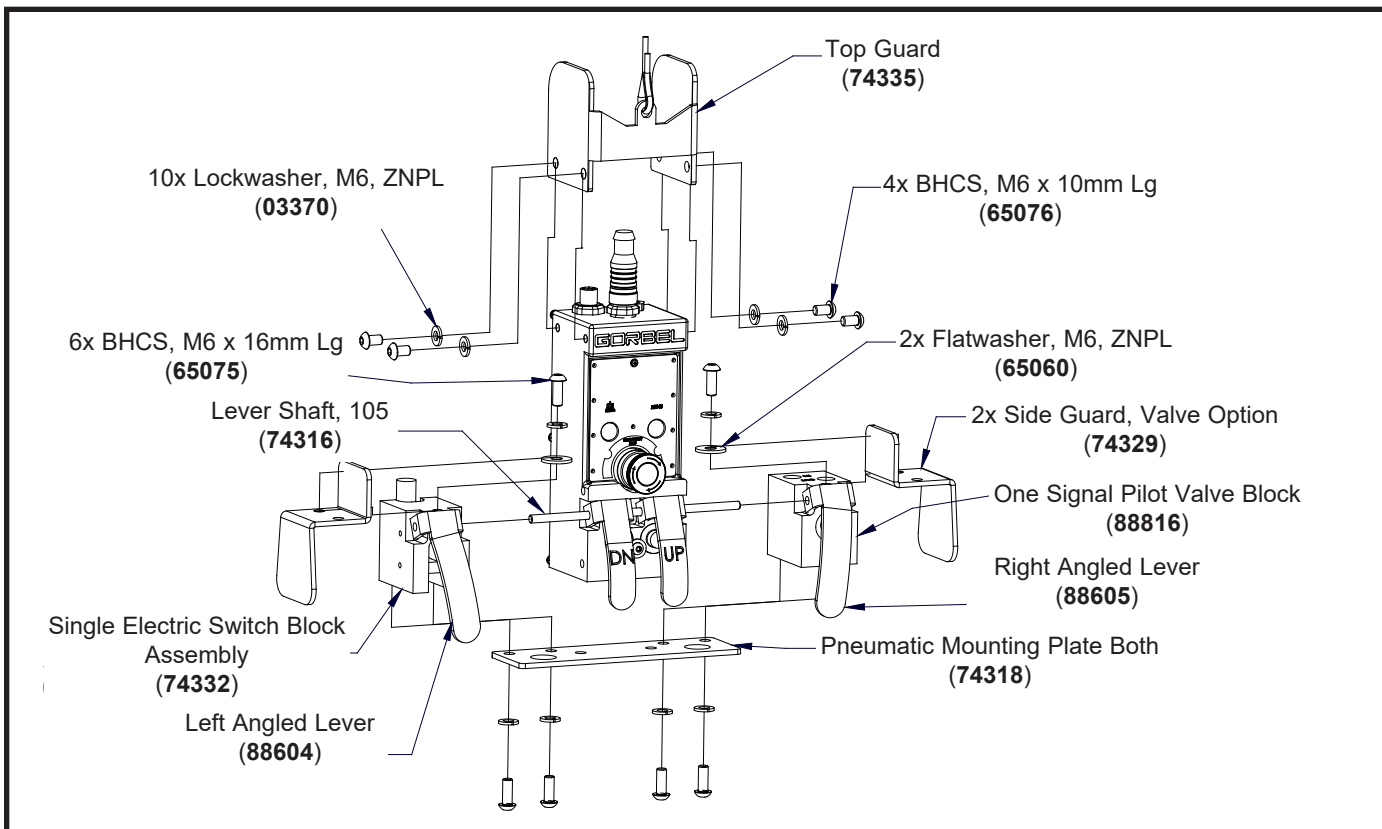

Electric Switch Left Side, Valve Right Side.

This page is intentionally left blank.

Removal & Replacement Procedures

FORCE SENSING HANDLE

Note: The following procedures assume any electrical or support cables have been disconnected prior to performing any repairs on the Pendant Handle itself.

Procedure F-1A. Remote Mount Cap Sub-Assembly Removal

Note: This procedure assumes the handle has already been removed from a remote mount bracket or similar mounting device.

1. Remove M16 hex head cap screw (HHCS), flatwasher and lockwasher from the top of the handle assembly.
2. Slide the remote mount cap off the handle shaft. Note the orientation of the internal electrical connector located below the remote mount cap.

Procedure F-1B. Remote Mount Cap Sub-Assembly Replacement

1. Slide the remote mount cap onto the handle shaft. Note the orientation of the internal electrical connector located below the remote mount cap.
2. Position the handle assembly into the remote mount bracket (if applicable) and install M16 hex head cap screw (HHCS), flatwasher and lockwasher onto the top of the handle assembly.

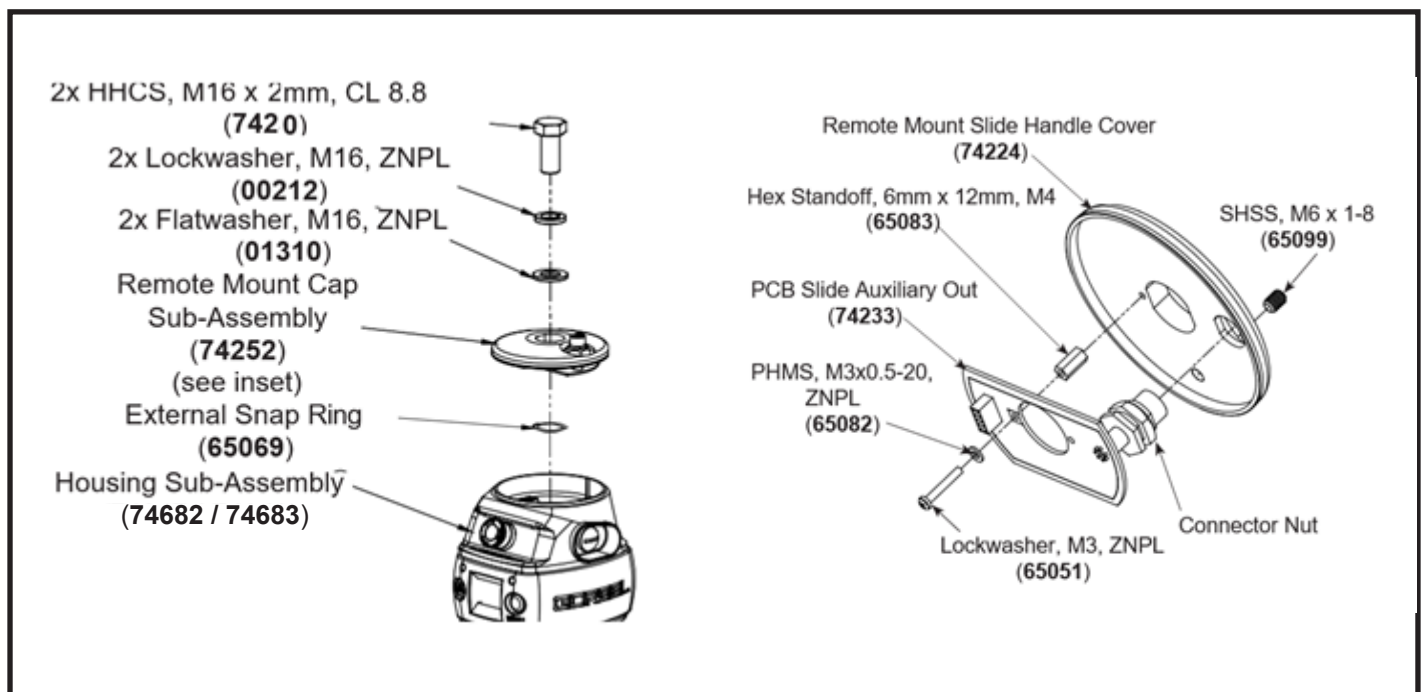

Diagram F-1. Remote Mounted Force Sensing Handle Remote Mount Cap Sub-Assembly Removal and Replacement.

Note: See Procedure S-1 (Slide Handle) to view the removal/replacement of the swivel sub-assembly. These are identical processes for Force Sensing Handles and Slide Handles.

Procedure F-2A. Housing Sub-Assembly Disassembly

1. Remove the remote mount cap sub-assembly. Refer to Procedure F-1A.
2. Remove the housing sub-assembly. Refer to Procedure F-2A.
3. Remove (3) M6 socket head cap screws (SHCS) from the mount plate. **Note:** Do not remove the mount plate as it is attached via the load cell sensor cable. Rotate as little as necessary to perform the following step.
4. Remove (4) M5 socket head cap screws (SHCS) and M5 flatwashers.
5. Separate the handle top sub-assembly from the handle bottom. Use caution, the ribbon cable and ground wire will still be connected. **Note:** Do not put excess strain on the loadcell sensor cable until it is detached from the motherboard by depressing the latch on the RJ45 connector.
6. All the sub-assembly internal components can be removed or replaced using the exploded view drawings as reference.

Procedure F-2B. Housing Sub-Assembly Reassembly

1. All the sub-assembly internal components can be removed or replaced using the exploded view drawings as reference.
2. Once all the internal components have been positioned properly, slide the handle bumper in place on the handle bottom (if removed) and join the handle top sub-assembly with the handle bottom. Make sure the ribbon cable, loadcell sensor cable, and ground wire are connected properly.
3. Install the (4) M5 socket head cap screws (SHCS) and M5 flatwashers, rotating the mount plate as little as necessary.
4. Install the (3) M6 socket head cap screws (SHCS) securing the mount plate.
5. Install the housing sub-assemblies onto the handle shaft. Refer to Procedures F-2B.
6. Install the remote cap sub-assemblies as required. Refer to Procedures F-1B.

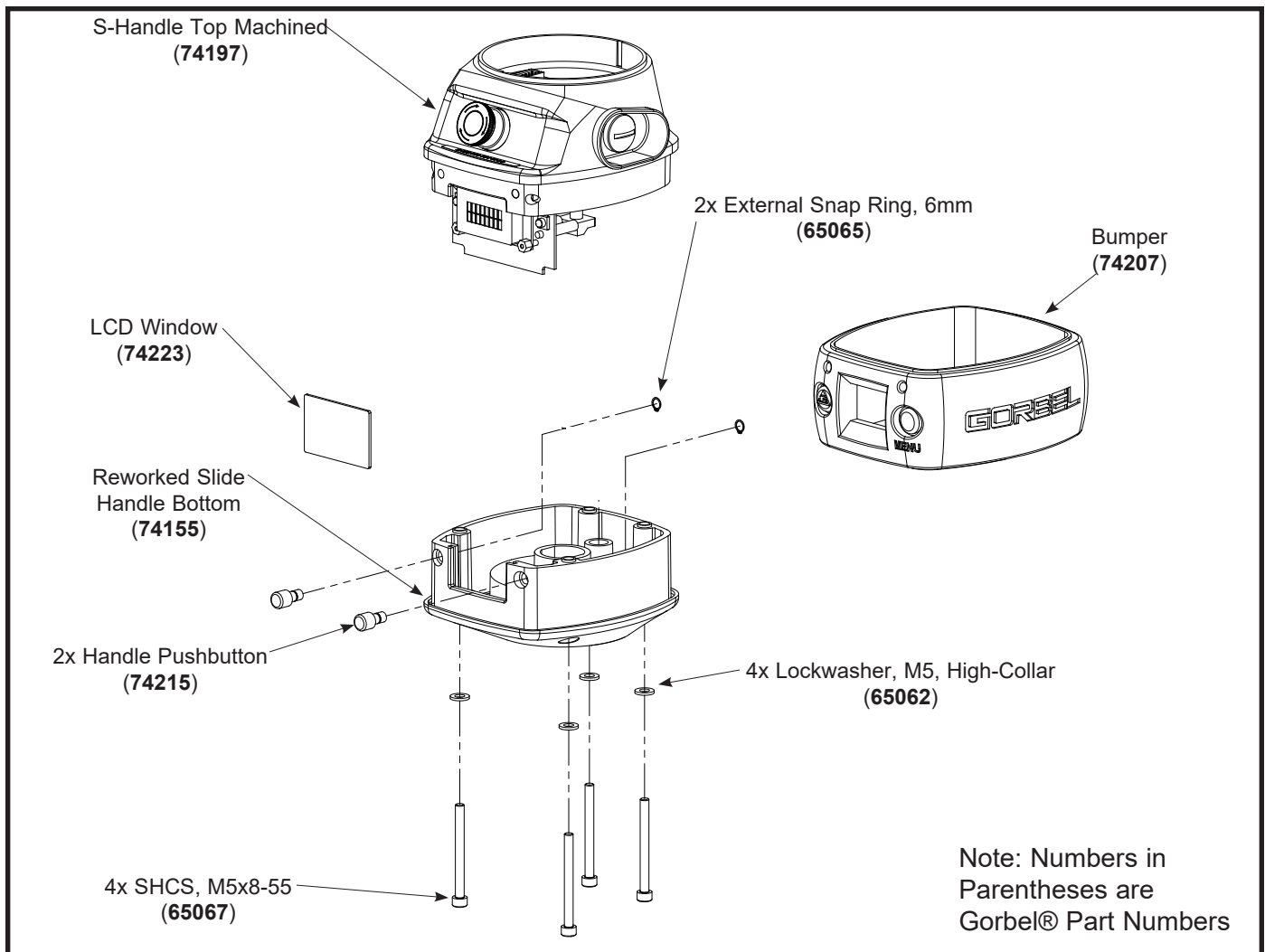

Diagram F-2a. Housing Sub-Assembly Assembly and Disassembly

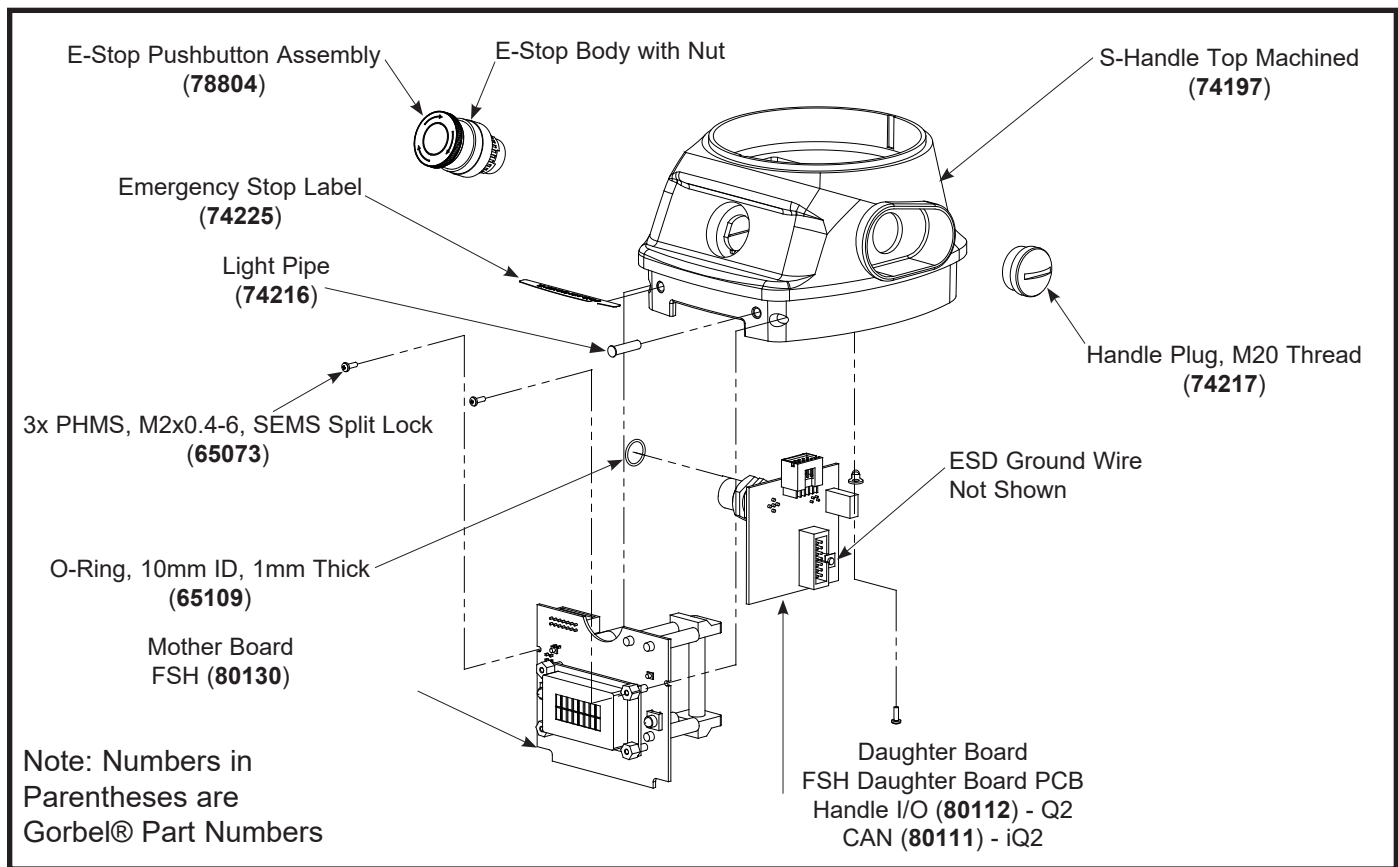
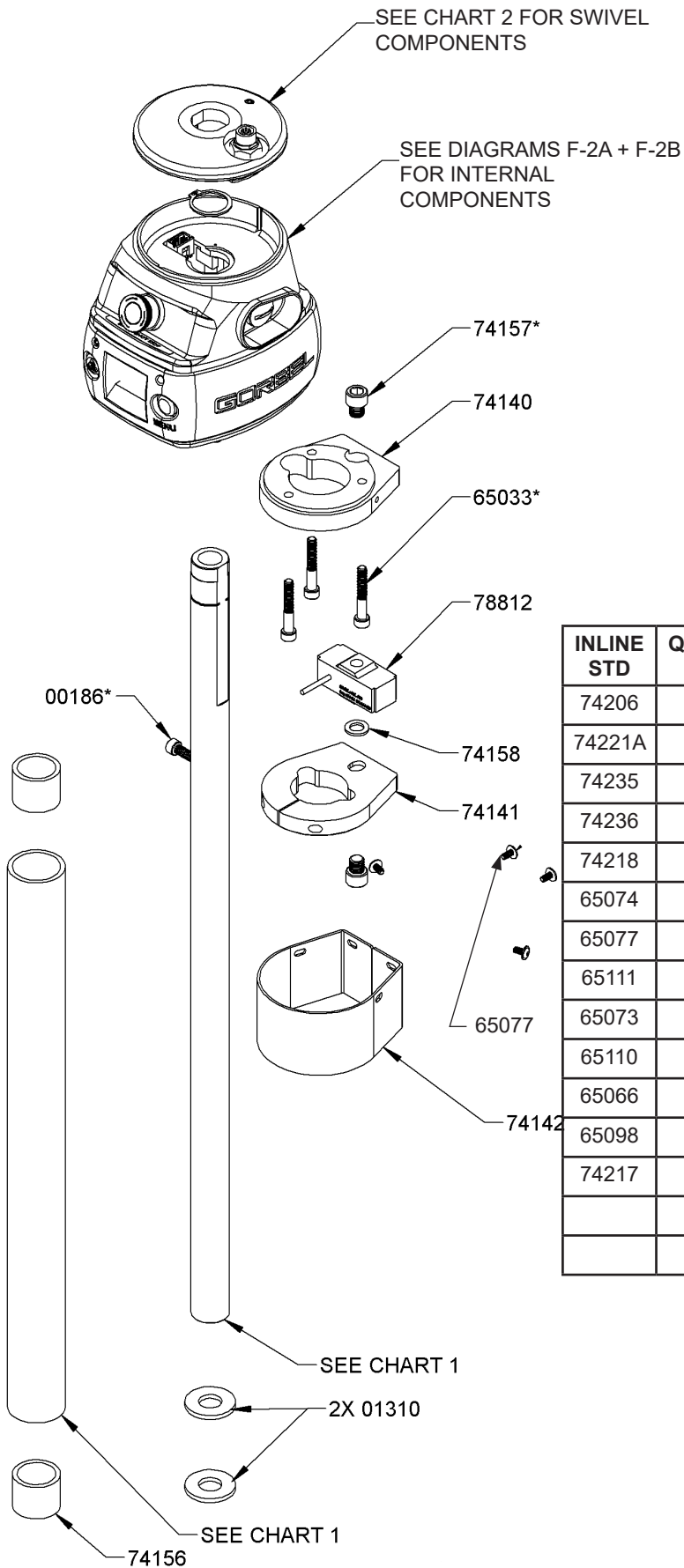

Diagram F-2b. Housing Sub-Assembly Assembly and Disassembly

Non-Reeved G-Force, Easy Arm, and Remote Slide Handles



| GRIP | SHAFT |
|-------------------------|-------------------------|
| 74146 24" (SHORT) | 74144 24" (SHORT) |
| 74145 36" (LONG) | 74143 36" (LONG) |

CHART 1

| INLINE STD | QUANTITY | INLINE AIR | QUANTITY | REMOTE | QUANTITY |
|------------|----------|------------|----------|--------|----------|
| 74206 | 1 | " | 1 | 74224 | 1 |
| 74221A | 1 | " | 1 | 74233 | 1 |
| 74235 | 1 | " | 1 | 65083 | 1 |
| 74236 | 1 | " | 1 | 65082 | 1 |
| 74218 | 1 | " | 1 | 65051 | 1 |
| 65074 | 1 | " | 1 | 65066 | 2 |
| 65077 | 1 | " | 1 | 01310 | 2 |
| 65111 | 4 | " | 4 | 00212 | 2 |
| 65073 | 3 | " | 3 | | |
| 65110 | 12 | " | 12 | | |
| 65066 | 1 | 74281 | 1 | | |
| 65098 | 1 | " | 1 | | |
| 74217 | 1 | 74269 | 2 | | |
| | | 74240 | 1 | | |
| | | 74241 | 1 | | |

CHART 2
(SWIVEL COMPONENTS)

Reeved G-Force (1320) Slide Handles

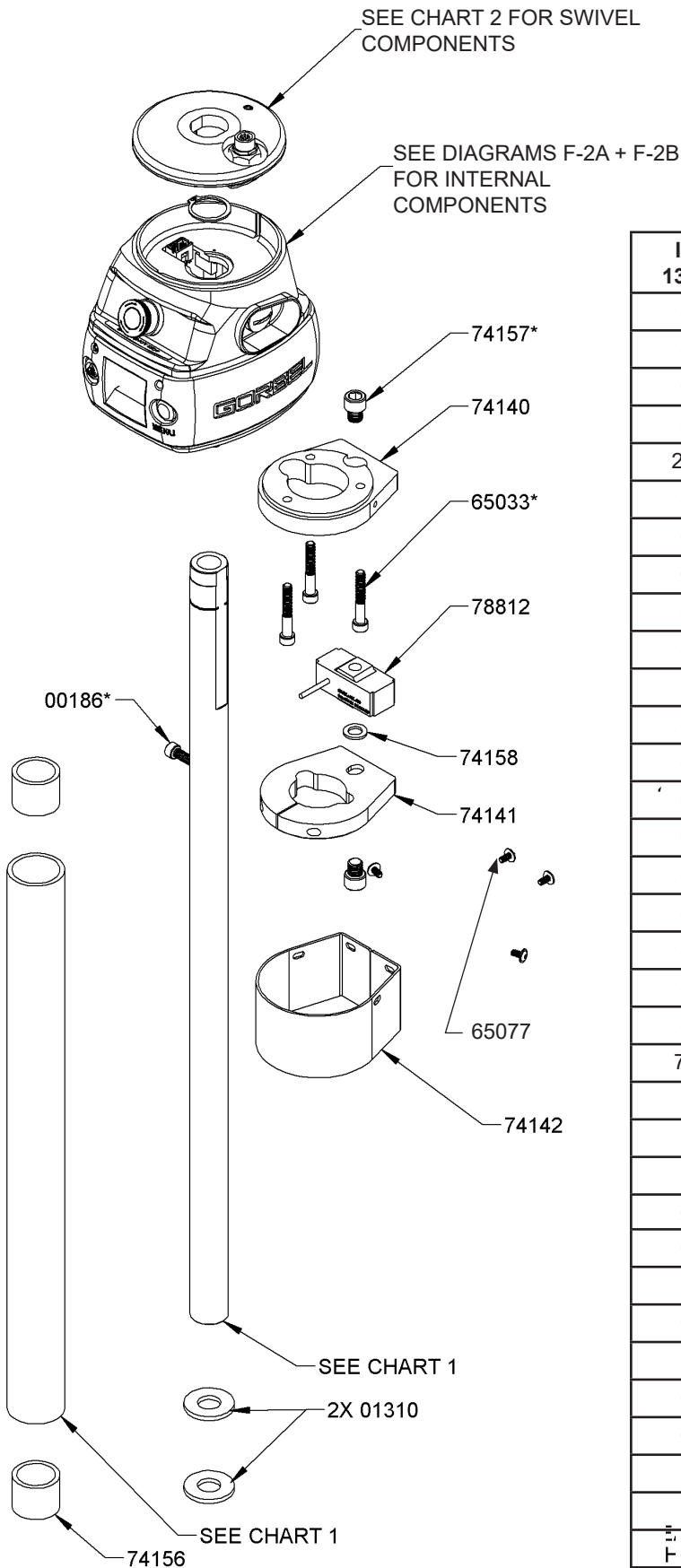

| GRIP | SHAFT |
|-------------------------|-------------------------|
| 74146 24" (SHORT) | 74144 24" (SHORT) |
| 74145 36" (LONG) | 74143 36" (LONG) |

CHART 1

| INLINE 1320 STD | QUANTITY | INLINE 1320 AIR | QUANTITY |
|-----------------|----------|-----------------|----------|
| 83255 | 1 | " | 1 |
| 83261 | 1 | " | 1 |
| 65086 | 1 | " | 1 |
| 83259 | 2 | " | 2 |
| 2001.12 | 2 | " | 2 |
| 83258 | 1 | " | 1 |
| 65018 | 4 | " | 4 |
| 65052 | 4 | " | 4 |
| 83250 | 1 | " | 1 |
| 83254 | 2 | " | 2 |
| 83257 | 2 | " | 2 |
| 83264 | 6 | " | 6 |
| 83263 | 2 | " | 2 |
| 03370 | 2 | " | 2 |
| 01764 | 2 | " | 2 |
| 83256 | 2 | " | 2 |
| 83266 | 4 | " | 4 |
| 83267 | 2 | " | 2 |
| 83253 | 1 | " | 1 |
| 83251 | 1 | " | 1 |
| 74221A | 1 | " | 1 |
| 74235 | 1 | " | 1 |
| 74236 | 1 | " | 1 |
| 74218 | 1 | " | 1 |
| 65074 | 1 | " | 1 |
| 65077 | 1 | " | 1 |
| 65111 | 4 | " | 4 |
| 65073 | 3 | " | 3 |
| 65110 | 12 | " | 12 |
| 65066 | 1 | 74281 | 1 |
| 65098 | 1 | " | 1 |
| 74217 | 1 | 74269 | 2 |
| | | 74240 | 1 |
| | | 74241 | 1 |

CHART 2
(SWIVEL COMPONENTS)

Remote Force Sensing Hub

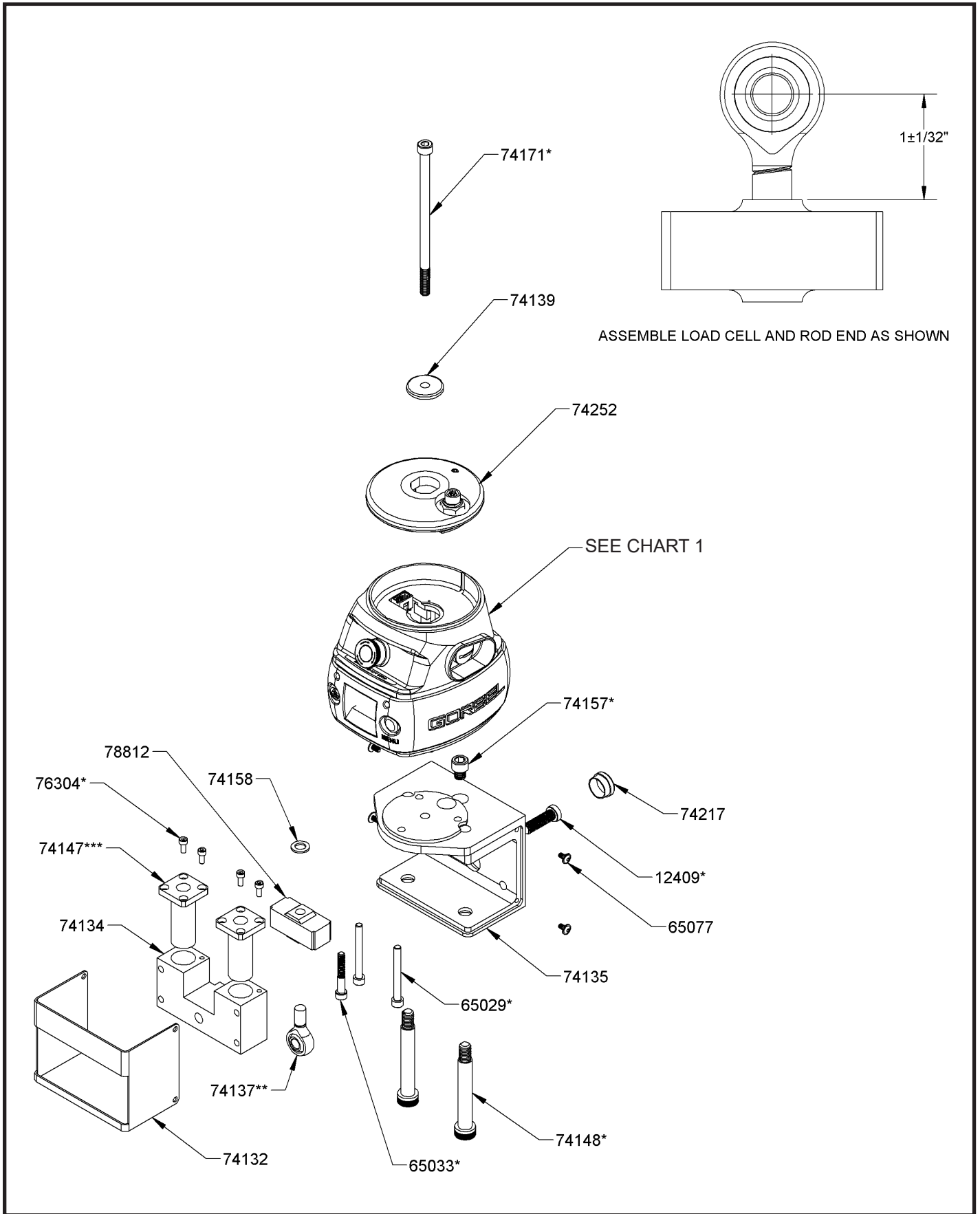

FSH HUB Options

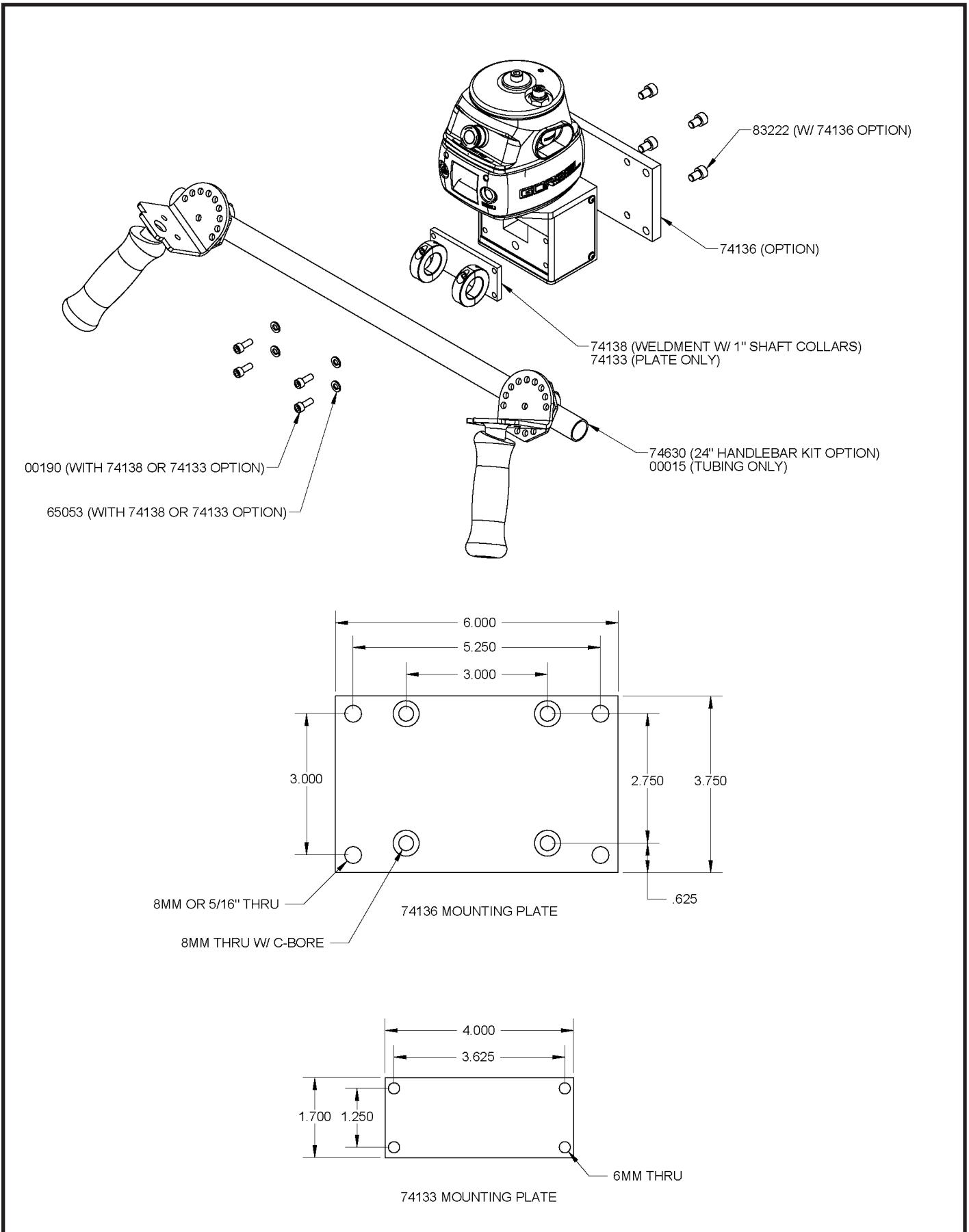

This page is intentionally left blank.

Removal & Replacement Procedures

COIL CORDS

Procedure C-1. Standard Coil Cord Assembly

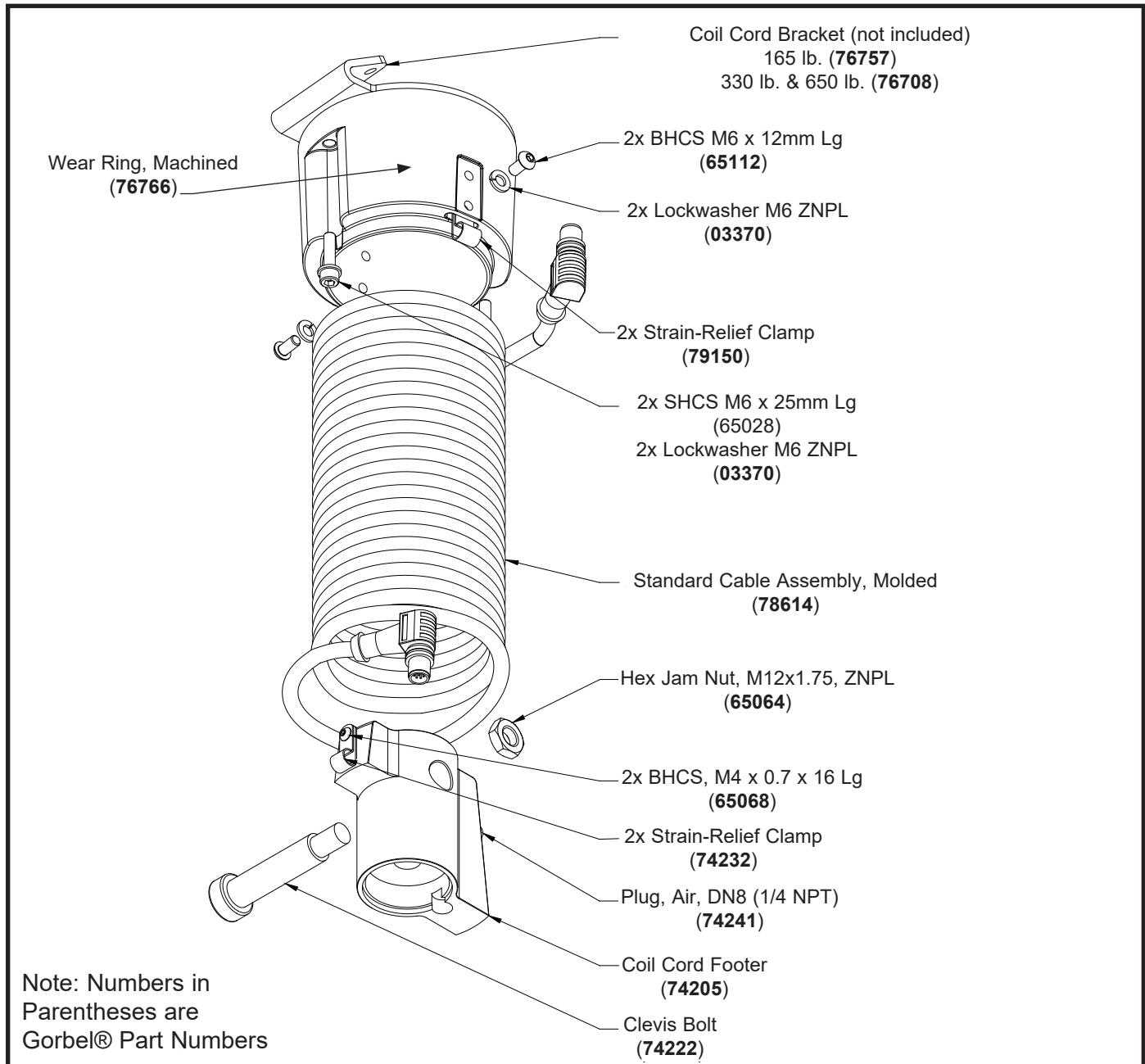

Diagram C-1. Standard Length Coil Cord Assembly

G-FORCE.COILCORD.ASSEMBLY

For replacement of entire Coil Cord Assembly use part name: G-FORCE.COILCORD.ASSEMBLY.

Procedure C-2. Double Length Coil Cord Assembly

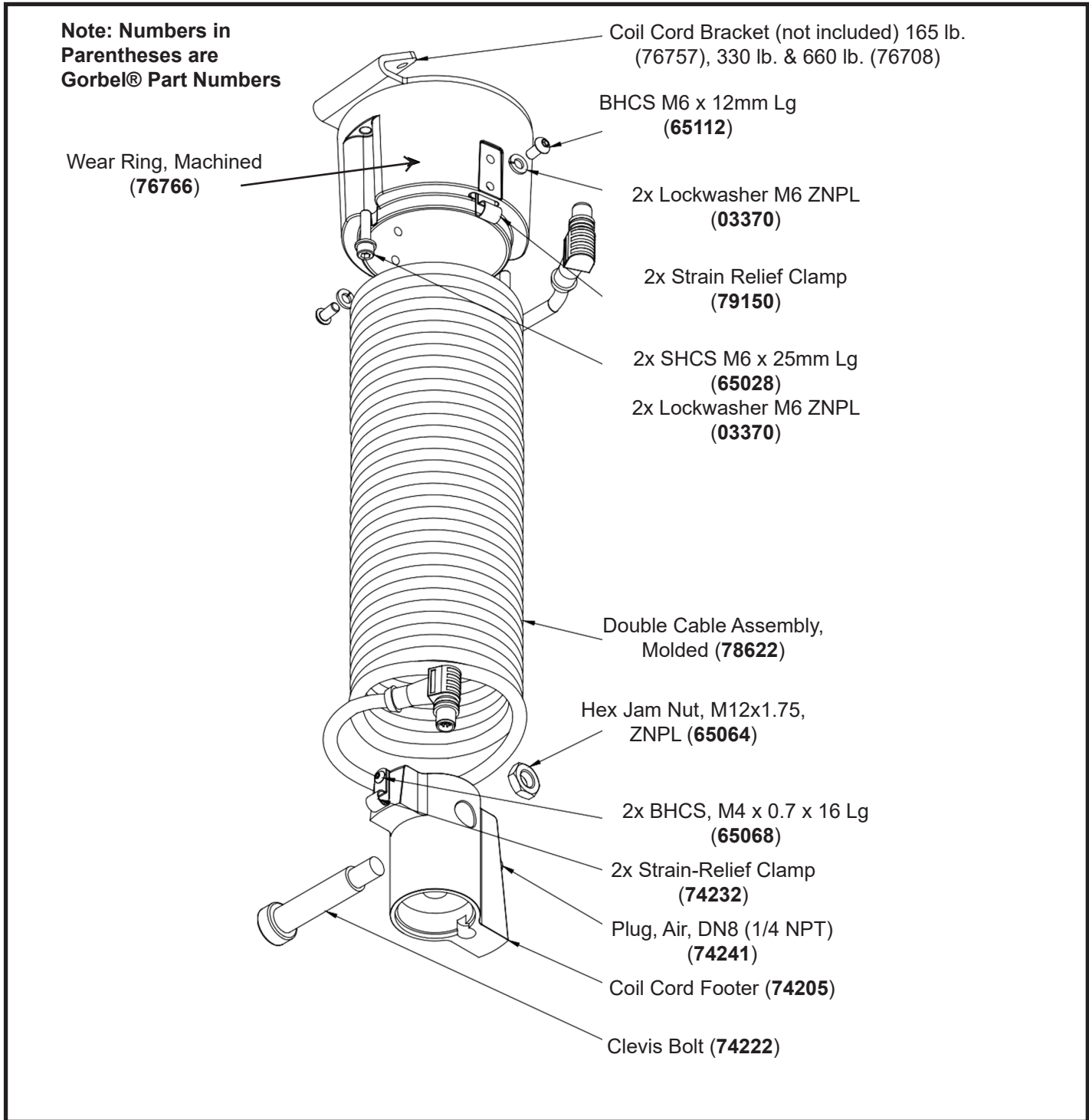

Diagram C-2. Double Length Coil Cord Assembly

G-FORCE.COILCORD.EXT.ASSEMBLY

For replacement of entire Coil Cord Assembly use part name: G-FORCE.COILCORD.EXT.ASSEMBLY.

Procedure C-3. Pendant Cord

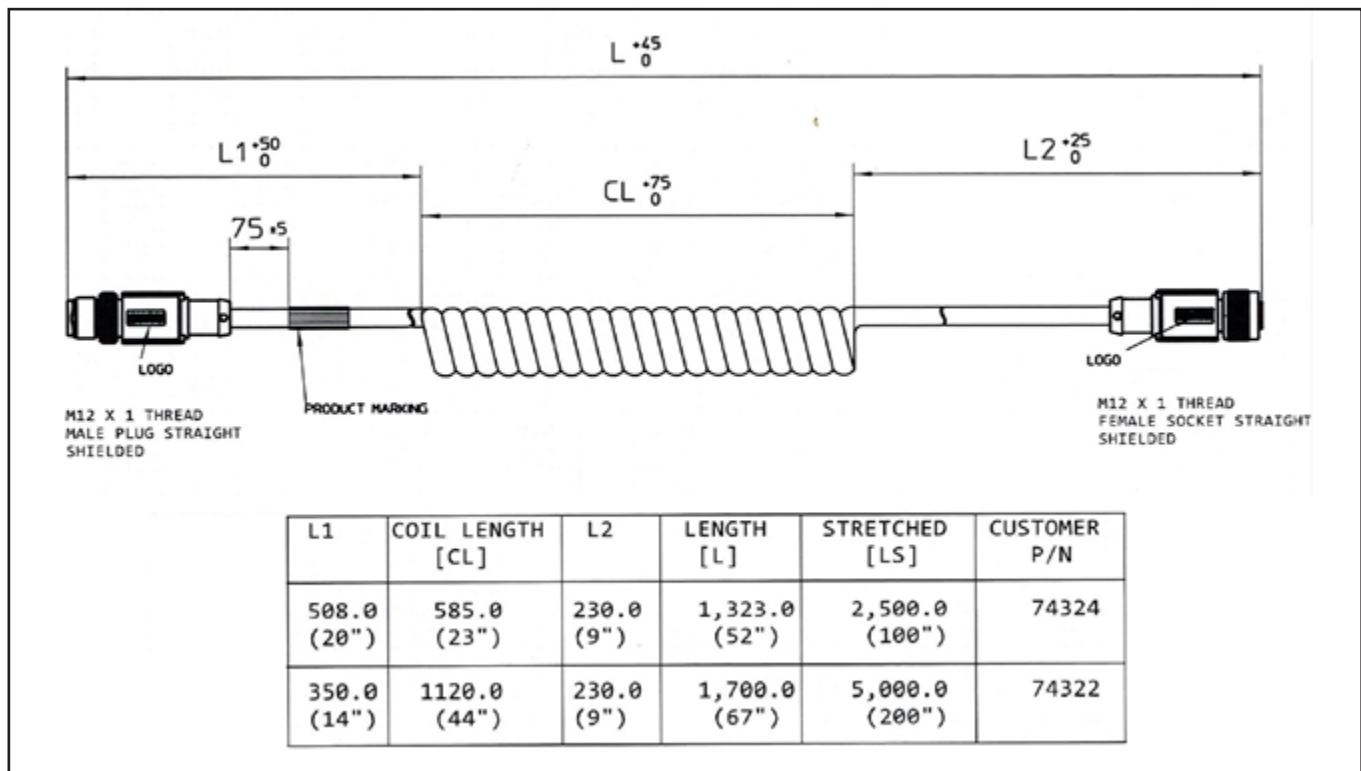

Diagram C-3. Pendant Cable (Electrical Portion Only)

G-FORCE.PENDANT.CABLE

For replacement of entire Cable Assembly use part name: G-FORCE.PENDANT.CABLE.

Procedure C-4. Standard Air Hose Assembly (G-FORCE.AIRHOSE.ASSEMBLY)

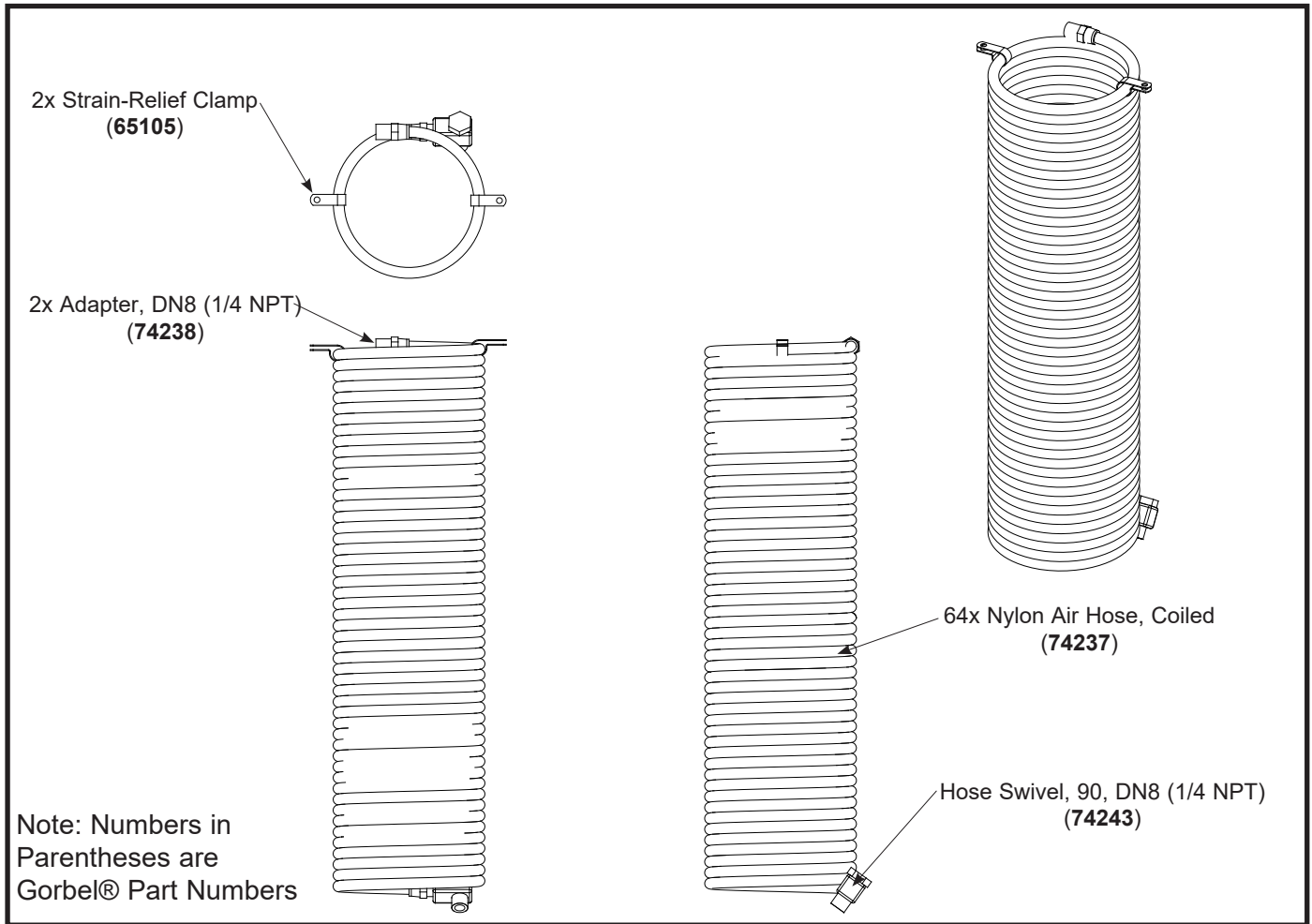

Diagram 4. Standard Air Hose Assembly

Note: The Extended Air Hose Assembly uses 2x as much Nylon Air Hose.

G-FORCE.AIRHOSE.ASSEMBLY

For replacement of entire Air Hose Assembly use part name: G-FORCE.AIRHOSE.ASSEMBLY.

G-FORCE.AIRHOSE.EXT.ASSEMBLY

For replacement of entire extended Air Hose Assembly use part name: G-FORCE.AIRHOSE.EXT.ASSEMBLY.

Removal & Replacement Procedures

G360™

Procedure G-1A. G360™ Disassembly Procedure

1. Remove M16 x 2 MM hex head cap screw (HHCS) and M16 Belleville washer from G360™ assembly. Note the orientation of the Belleville washer, concave side down.
2. Slide the swivel sub-assembly off the collector shaft. Note: Set aside the swivel sub-assembly with the PCBs facing upward to avoid damaging them.
3. Remove electrical connector nut from the slip ring PCB.
4. Remove the (2) M2 Phillips head machine screws (PHMS) that secure the slip ring PCB to the collector shaft.
5. Remove the air extension and nylon washer from collector shaft.
6. Remove (3) M3 socket head cap screws (SHCS) and M3 lockwashers from the collector shaft and slide the collector shaft out of the cover.

Procedure G-1B. G360™ Reassembly Procedure

1. Slide the collector shaft into the cover and secure it using the (3) M3 socket head cap screws and M3 lockwashers. Note the alignment of the output connector to the cover opening.
2. Install the air extension and nylon washer into the collector shaft.
3. Assemble the slip ring PCB to the collector shaft with (2) M2 Phillips head machine screws (PHMS).
4. Install the output connector nut on the slip ring PCB.
5. Slide the swivel sub-assembly onto the collector shaft. Carefully align connectors using the alignment grooves in the cover.
6. Install the M16 x 2 MM hex head cap screw (HHCS) and M16 Belleville washer onto the G360™ assembly. Note the orientation of the Belleville washer, concave side down.

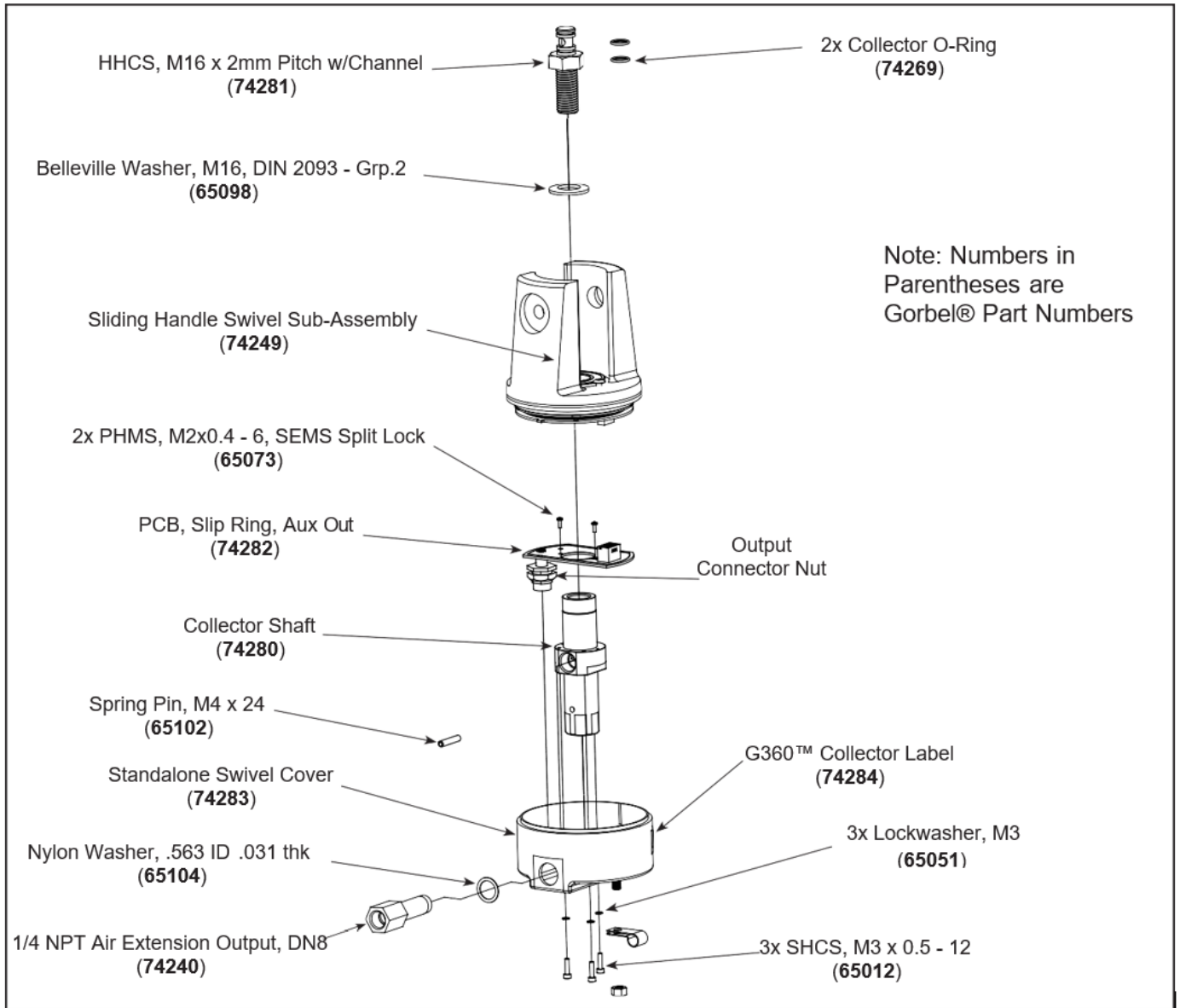

Diagram G-1a. G360 with Air Assembly and Disassembly

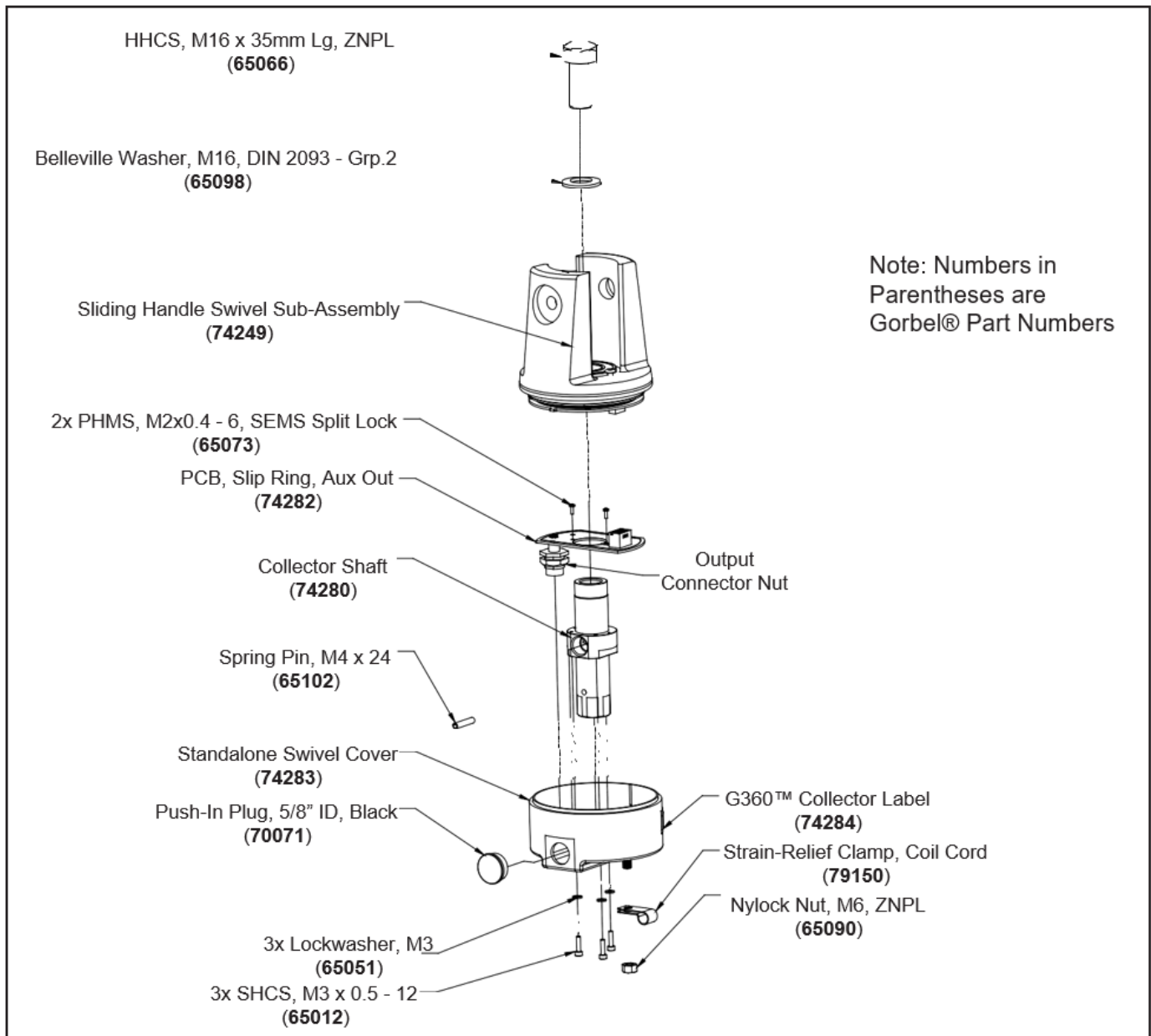

Diagram G-1b. G360 Assembly and Disassembly

This page is intentionally left blank.

Procedure G-2A. Swivel Sub-Assembly Disassembly Procedure

1. Remove the swivel sub-assembly from the G360™ assembly. Refer to Procedure G-1A.
2. Remove the C-ring from the swivel sub-assembly.
3. Remove the Delrin spacer washer from the swivel sub-assembly.
4. Remove the secondary slip ring PCB from the swivel casting. Be very careful to not deform the contacts on the PCB.
5. Remove the primary slip ring PCB from the swivel by removing the input connector nut,
6. (3) M2 Phillips head machine screws (PHMS), (4) nylon Phillips head machine screws (PHMS), and (12) flat-washers from the swivel casting.
7. Remove the bearing from the swivel casting if necessary. **Note:** *This bearing is pressed into the swivel casting.*

Procedure G-2B. Swivel Sub-Assembly Reassembly Procedure

1. Press the bearing into the swivel casting if it was replaced.
2. Install the primary slip ring PCB into the swivel casting by installing the input connector nut, (3) M2 Phillips head machine screws (PHMS), (4) nylon Phillips head machine screws (PHMS), and (12) flatwashers.
3. Install the secondary slip ring PCB into the swivel casting. Be very careful to not deform the contacts on the PCB.
4. Install the Delrin spacer washer onto the swivel sub-assembly.
5. Install the C-ring onto the swivel sub-assembly. Check to see that the assembly moves freely.
6. Install the swivel sub-assembly into the G360™ assembly. Refer to Procedure G-1B.

Note: Numbers in Parentheses are Gorbel® Part Numbers

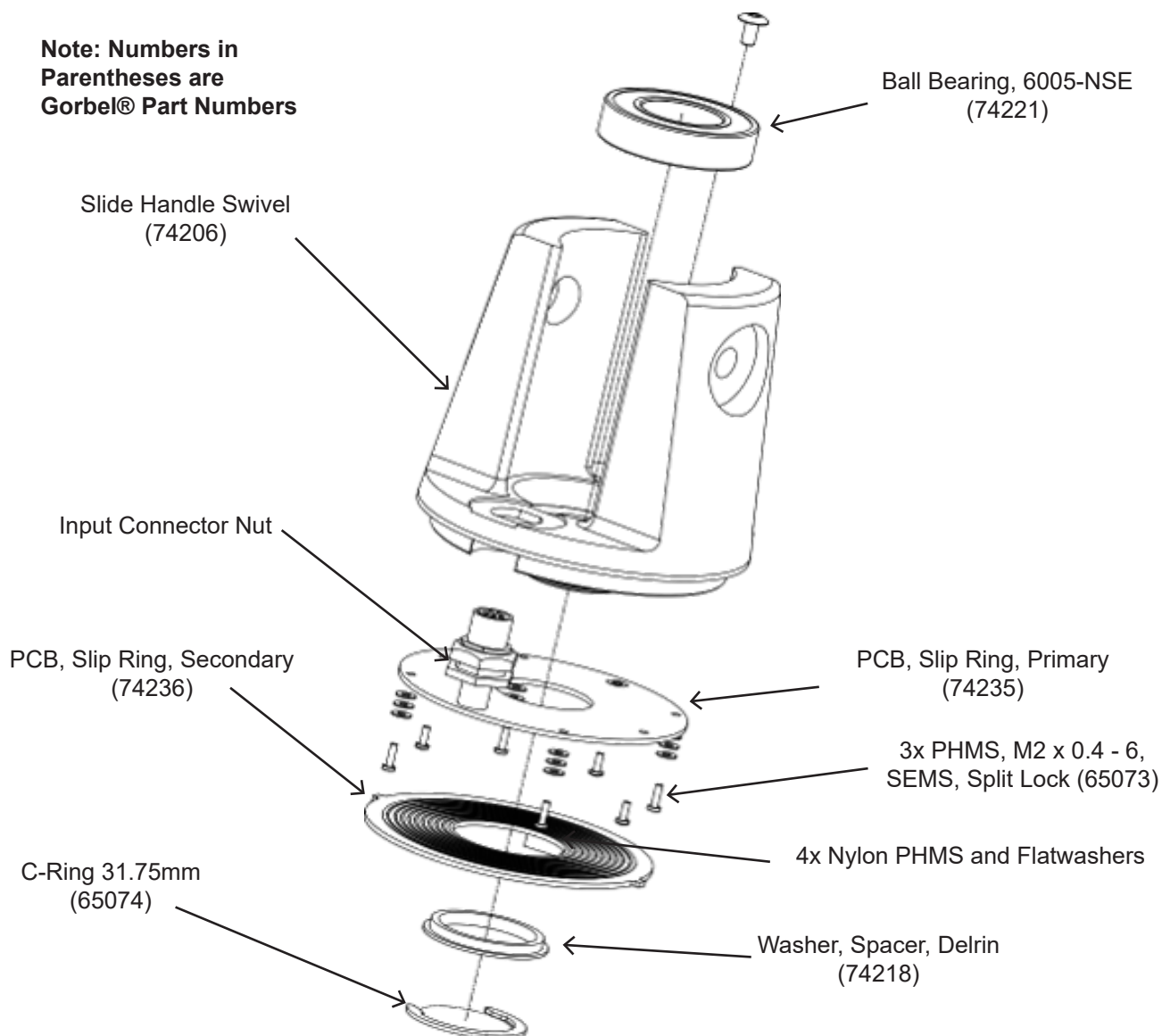
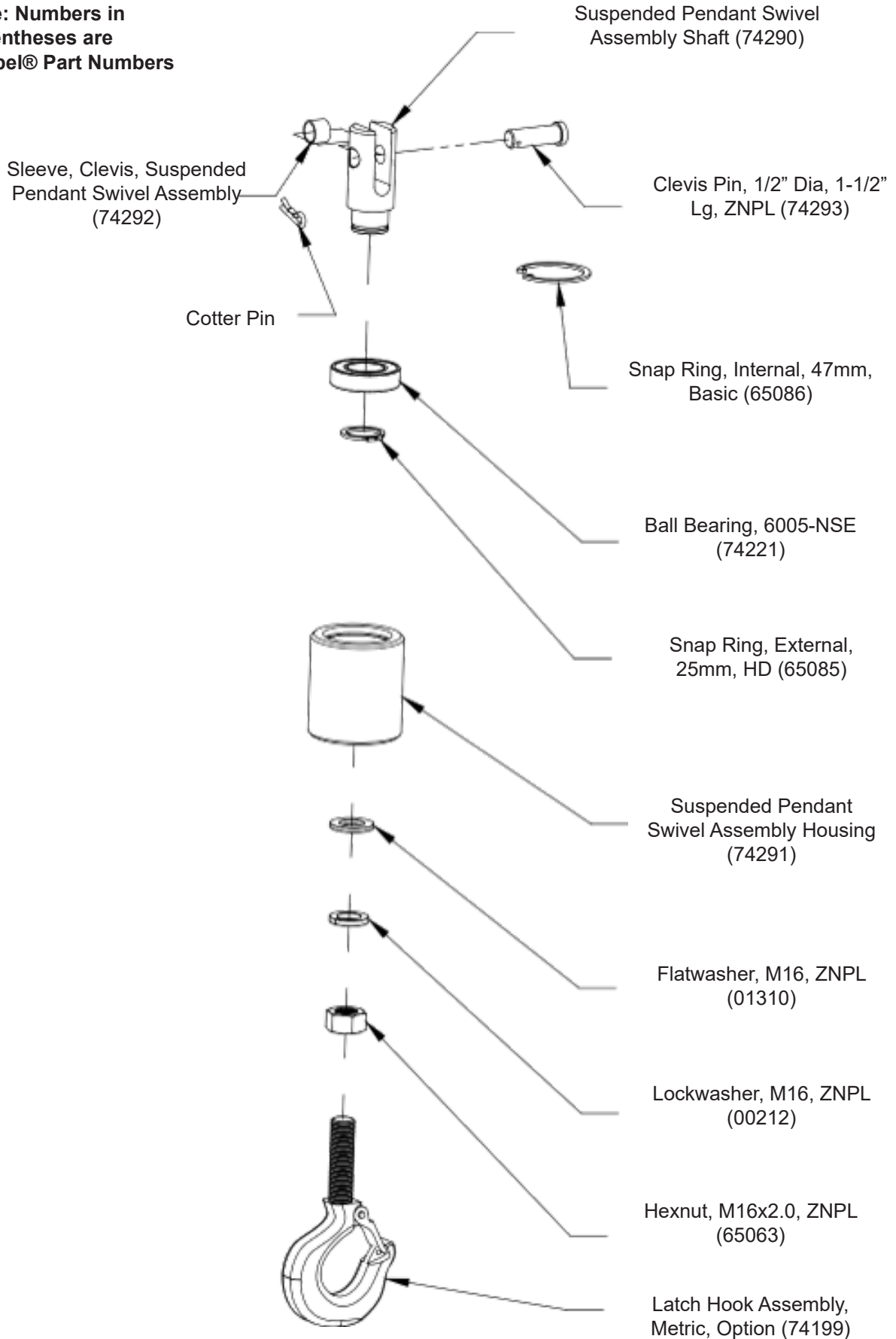

Diagram G-2. Swivel Sub-Assembly Disassembly and Reassembly.

Suspended Pendant Swivel Assembly

Note: Numbers in Parentheses are Gorbel® Part Numbers



Easy Arm Components 165-330 Only

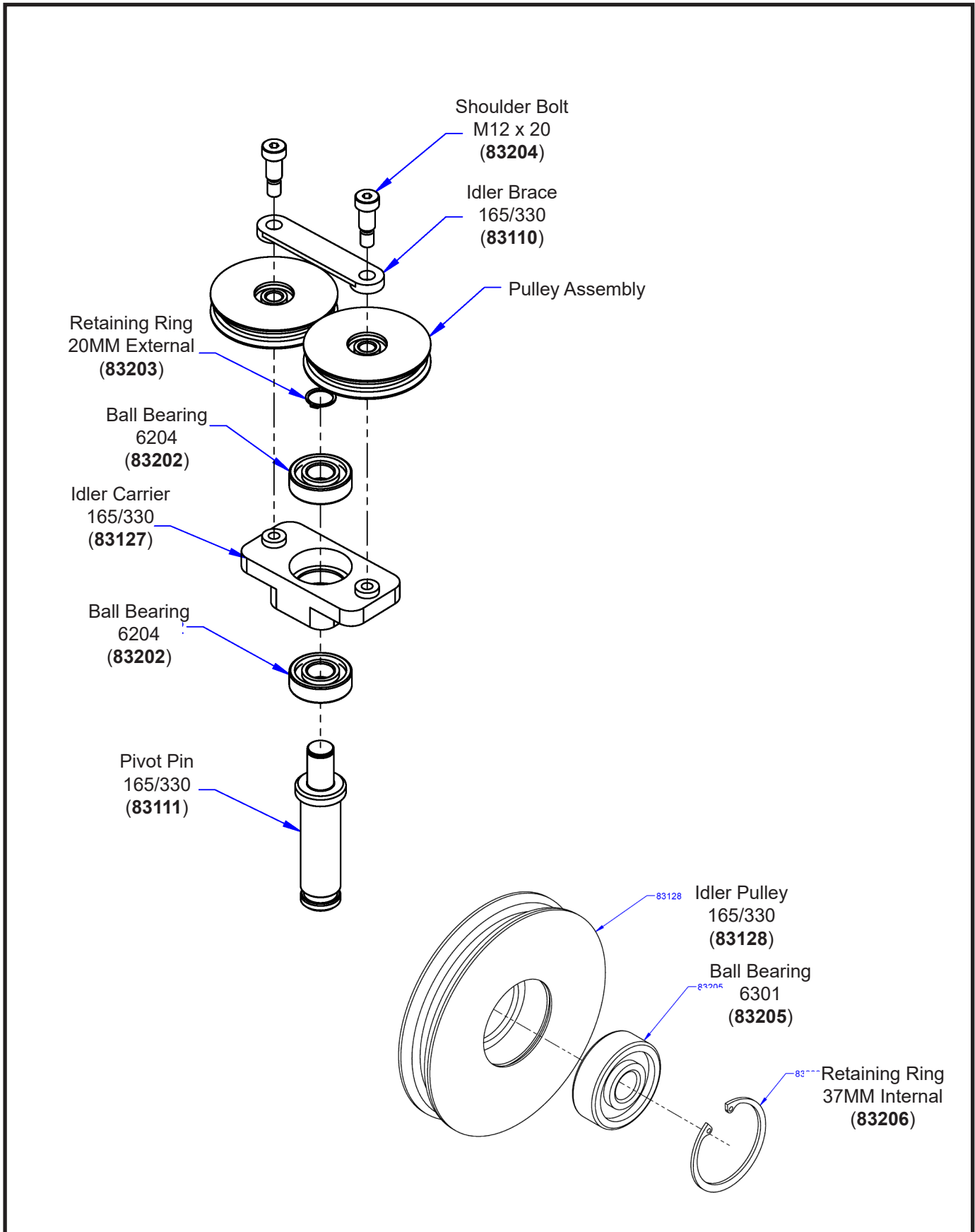

Pulley Block Assembly 165-330 Only

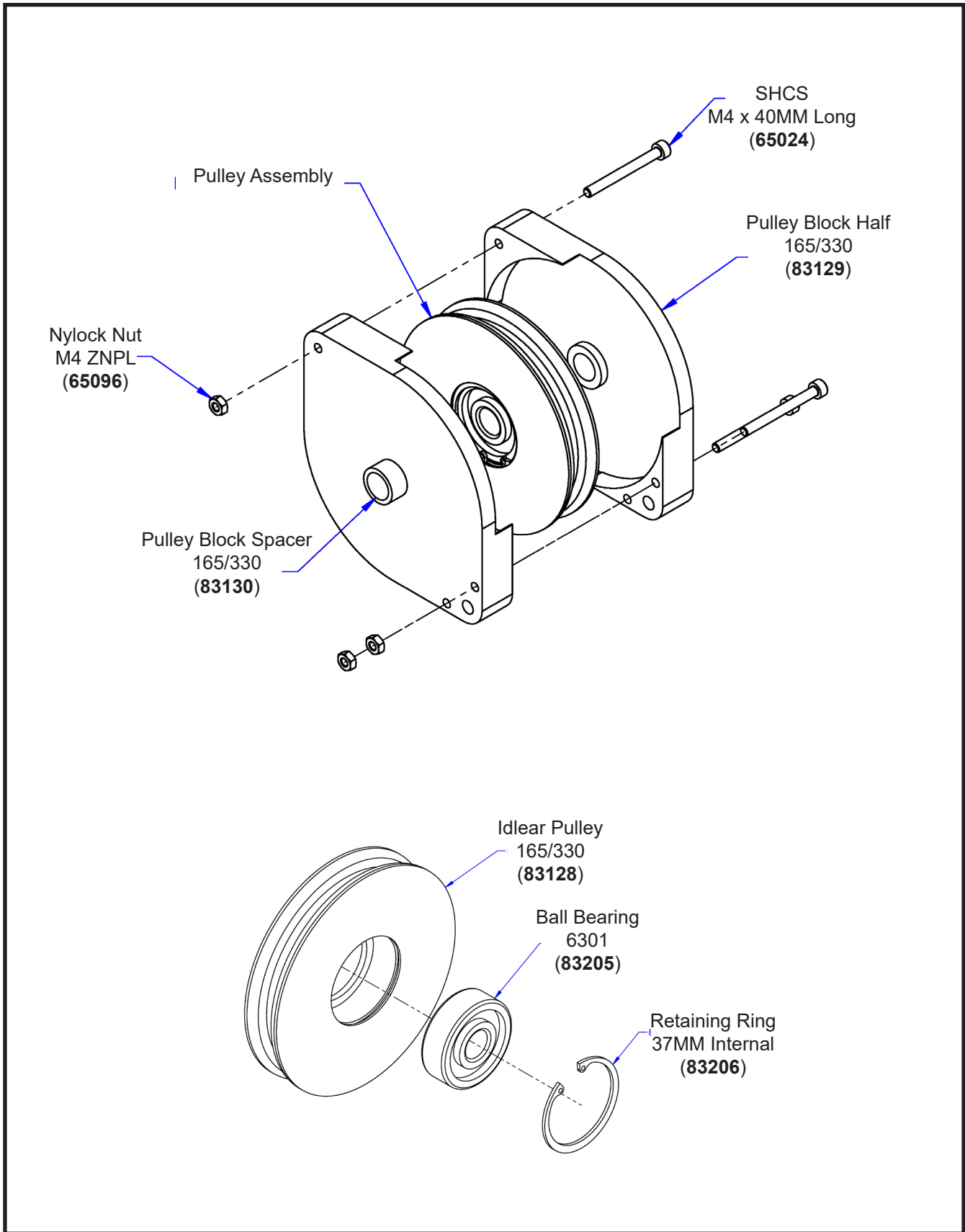

Follower Band Assembly
165-330 Only

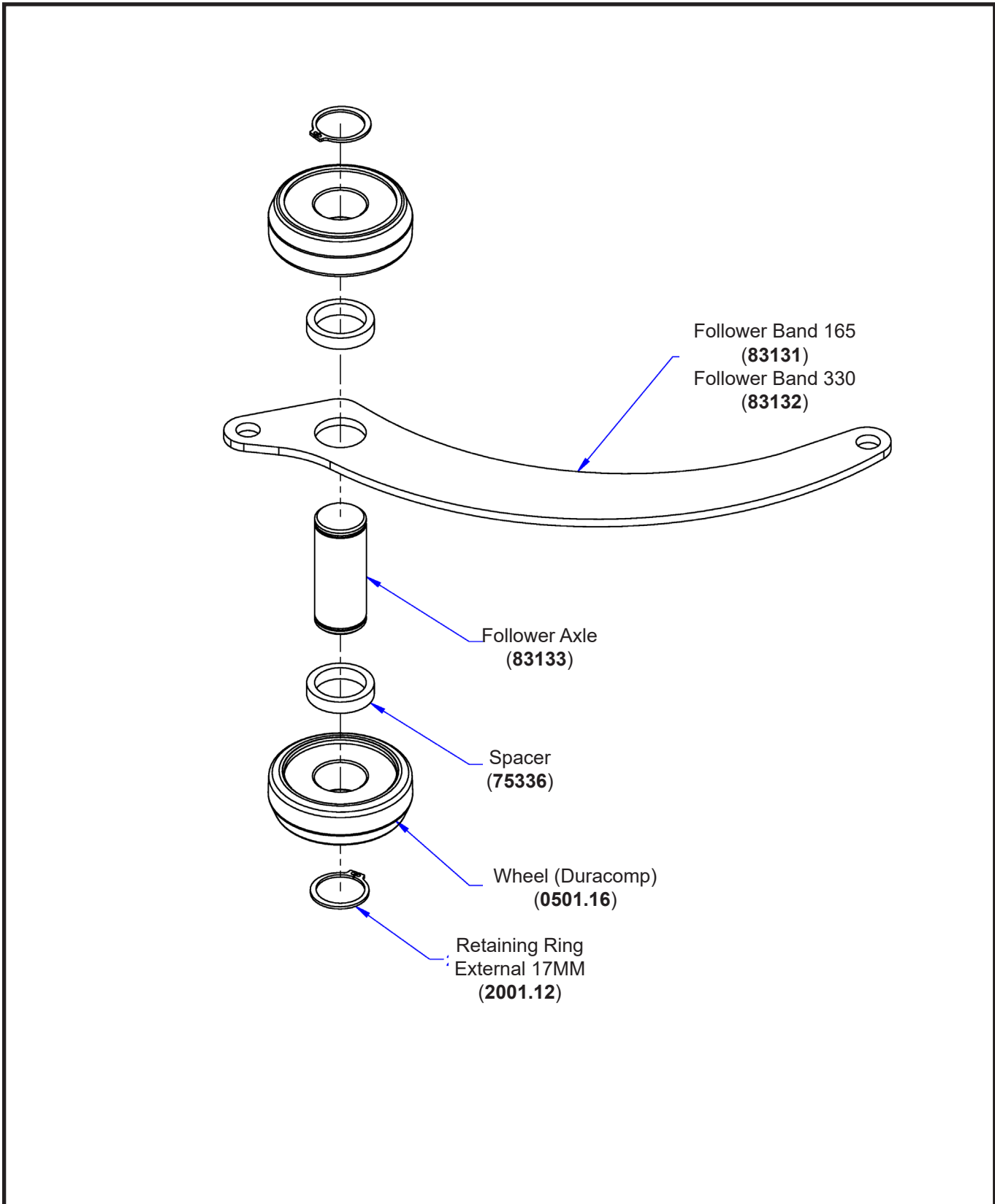

Bumper Assembly
165-330 Only

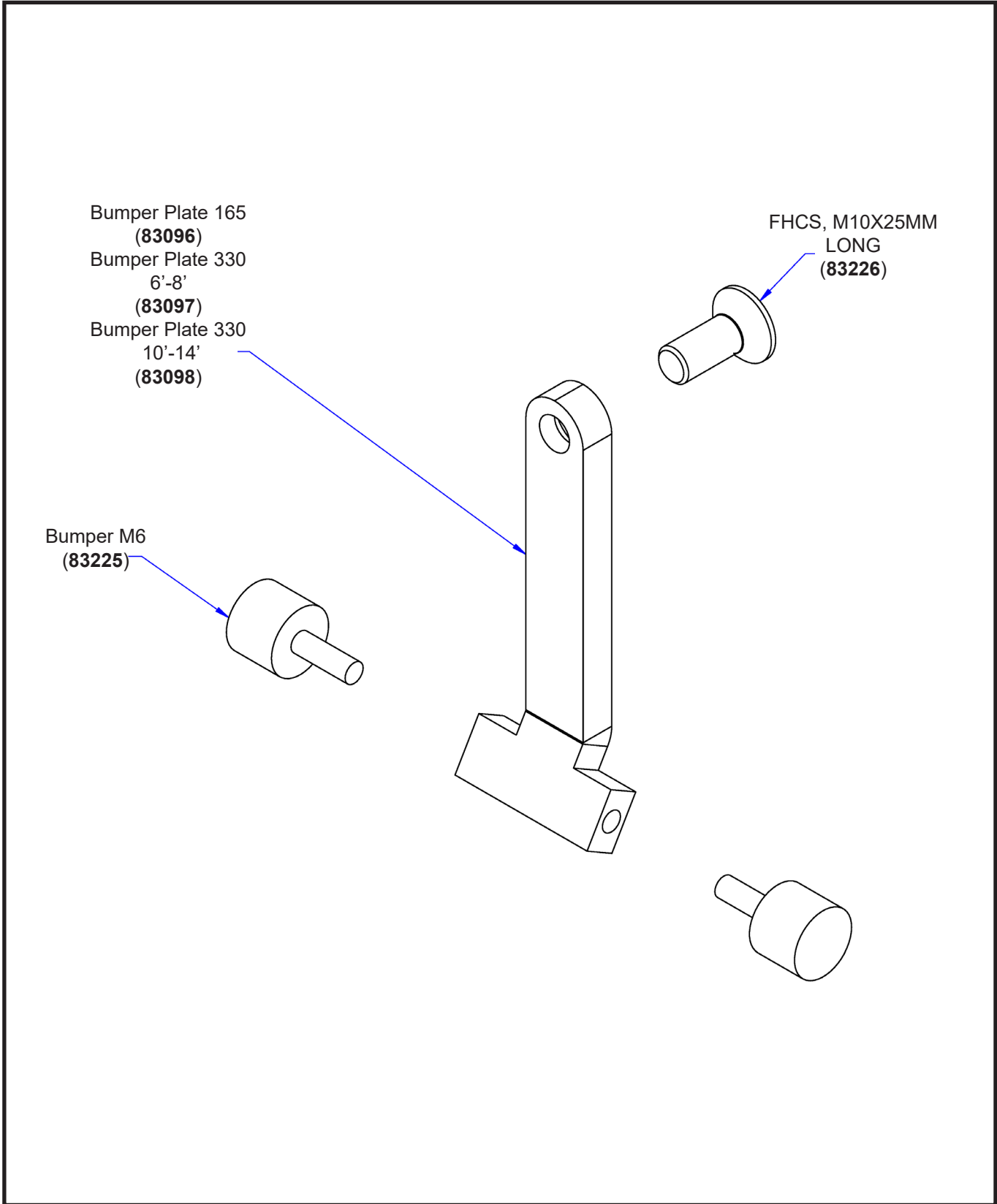

Actuator-Arm Assembly 165-330 Only

| P/N | Description |
|-------|---------------------------------|
| 83200 | Bearing Locknut, 5N08 |
| 83134 | Friction Break Ring, 165/330 |
| 83236 | SHCS, M8x300MM Long |
| 65103 | Nylock Nut, M8, ZNPL |
| 00194 | SHCS, M8x25mm Long |
| 08249 | Bearing, NTN Cone, #4T-LM501349 |
| 83235 | Follower Band Spring |

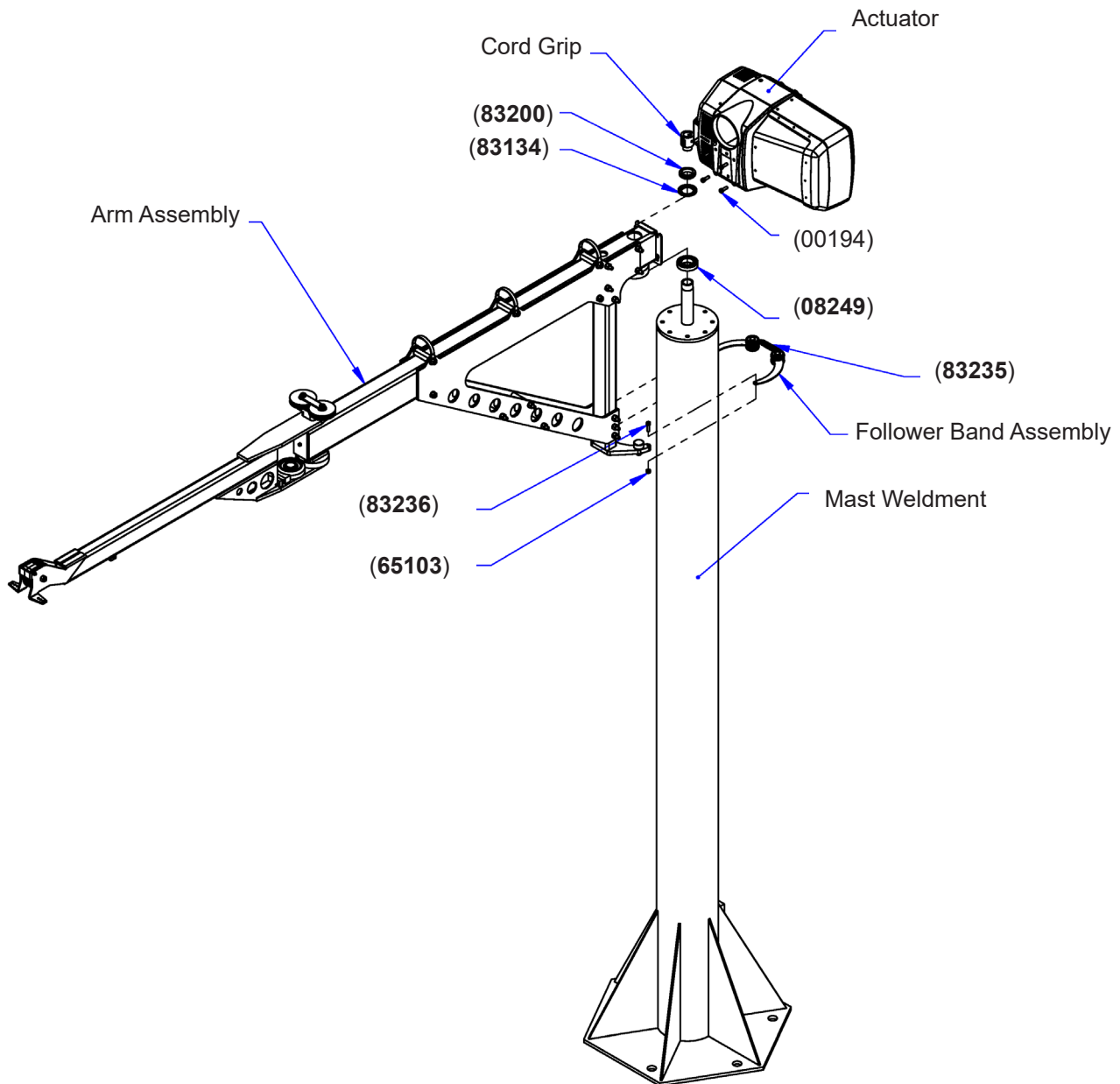

Arm Assembly 165-330 Only

| P/N | Description |
|-------|-----------------------------|
| 65034 | SHCS, M6x50MM Long |
| 65070 | Nylock Nut, M5 ZNPL |
| 83214 | Nylock Nut, M10 |
| 83213 | Shoulder Bolt, M6x60 |
| 83212 | SHSS, 12x60 Long |
| 83207 | Lock Washer, M20, ZNPL |
| 83202 | Ball Bearing 6204 |
| 83208 | SHSS, 20x30MM Long, M16-THD |

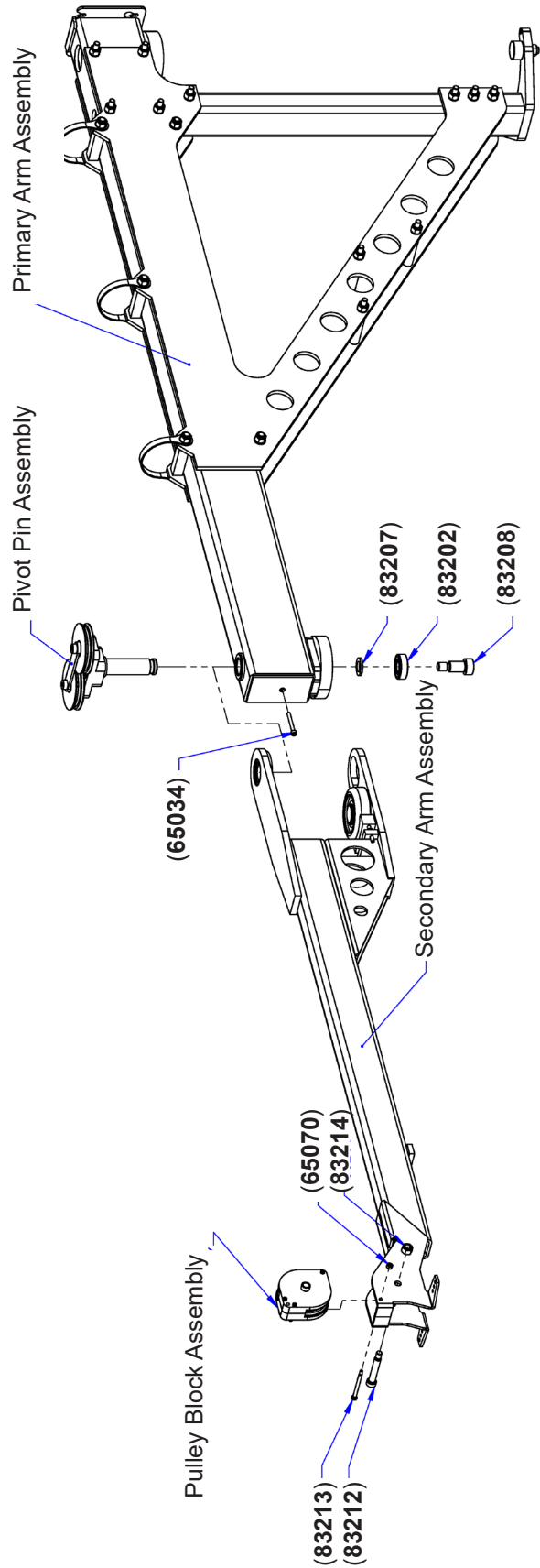

Head Assembly (1)
165-330 Only

| P/N | Description |
|--------|------------------------------------|
| 83224 | HHCS, M10x110MM Long |
| 83231 | HHCS, M10 1.5x120MM Long, 8.8 2NPL |
| 83232 | HHCS, M10x200 MM Long |
| 83140 | Side Plate, 165 6'-8' Span |
| 83147 | Side Plate, 165 10'-14' Span |
| 83090 | Side Plate, 330 10'-14' Span |
| 83091 | Side Plate, 330 6'-8' Span |
| 83109 | M12 Bushing |
| 83108 | M10 Bushing |
| 83214 | Nylock Nut M10 |
| 83149A | Side Plate Spacer 3" LG |
| 83149B | Side Plate Spacer 6" LG |
| 00258 | CAM Follower, 1 3/8" Diameter 165 |
| 83219 | CAM Follower 2" 330 |
| 00259 | Nylock Nut 1/2"-20 ZNPL |
| 83220 | Nylock Nut 7/8"-14 ZNPL GR8 |

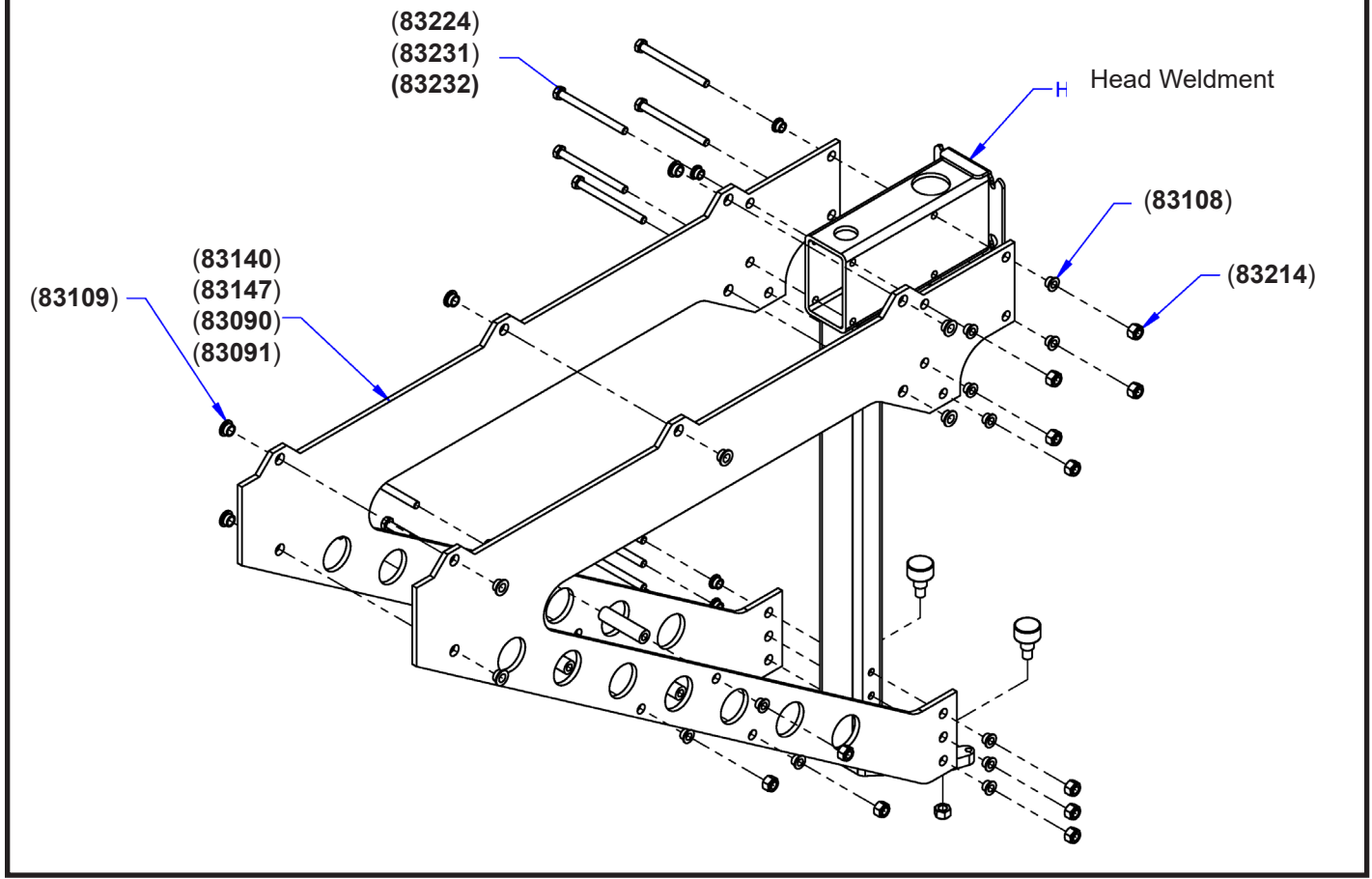

Head Assembly (2) 165-330 Only

NOTE: Refer to previous page for part numbers.

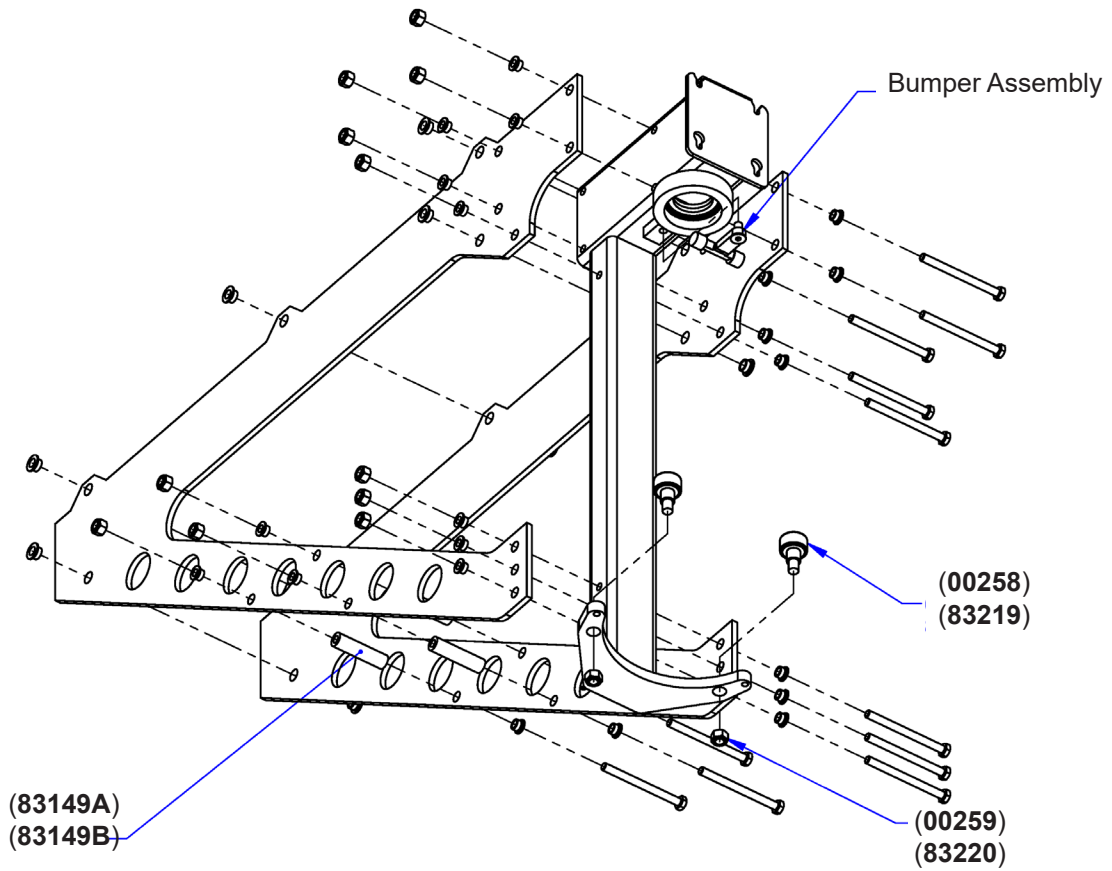

Secondary Arm Assembly 165-330 Only

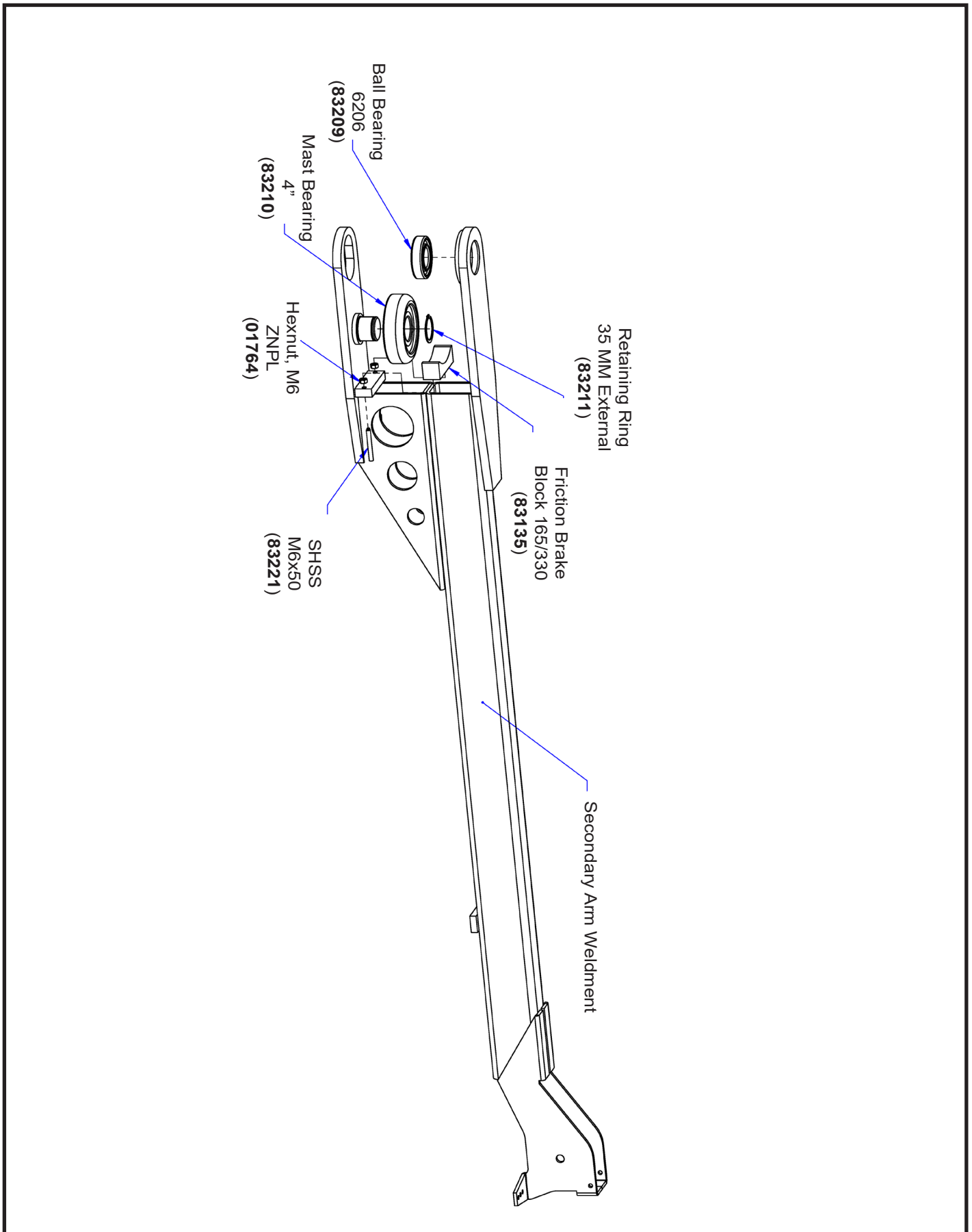

Primary Arm Assembly 165-330 Only

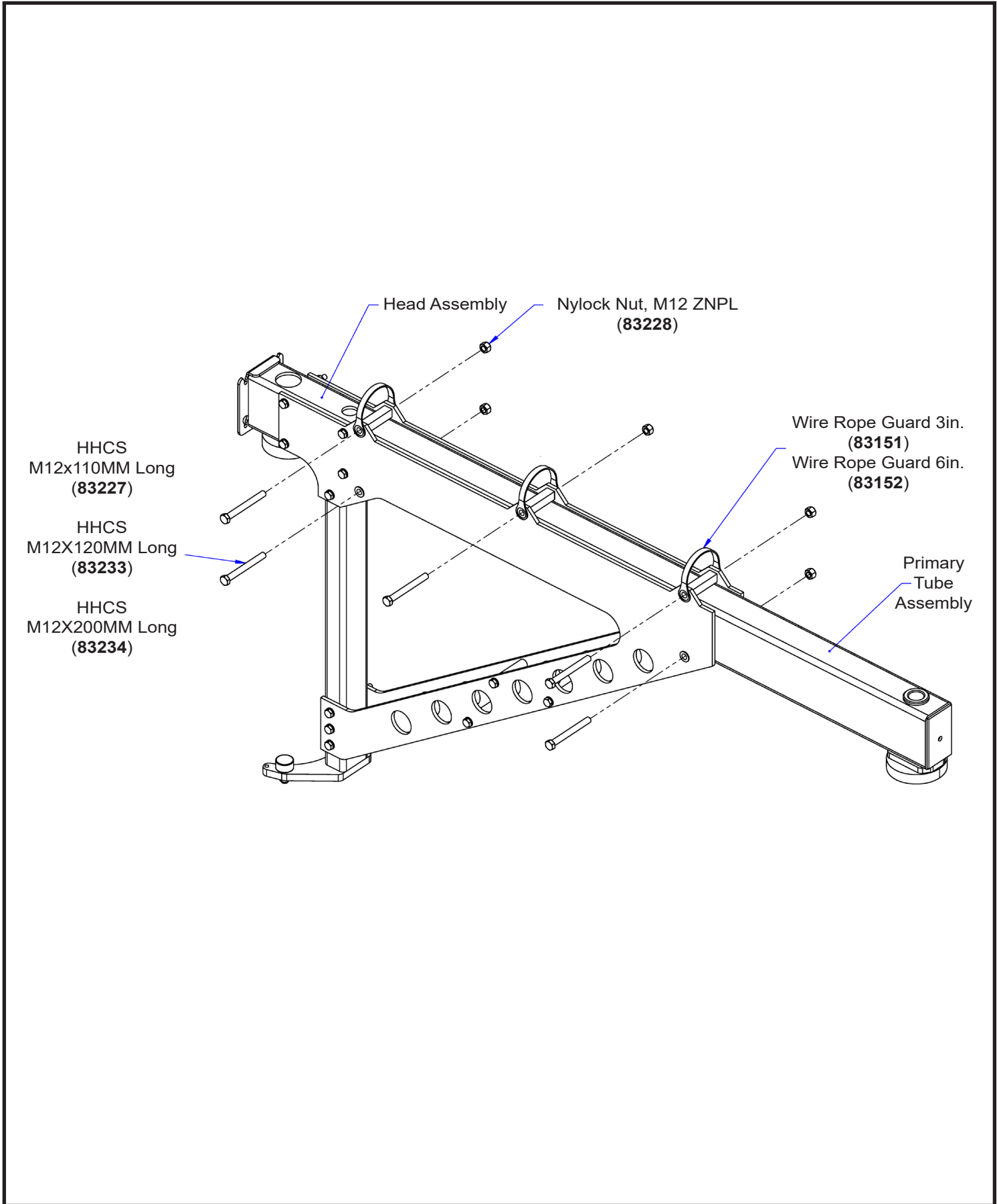

Primary Tube Assembly
165-330 Only

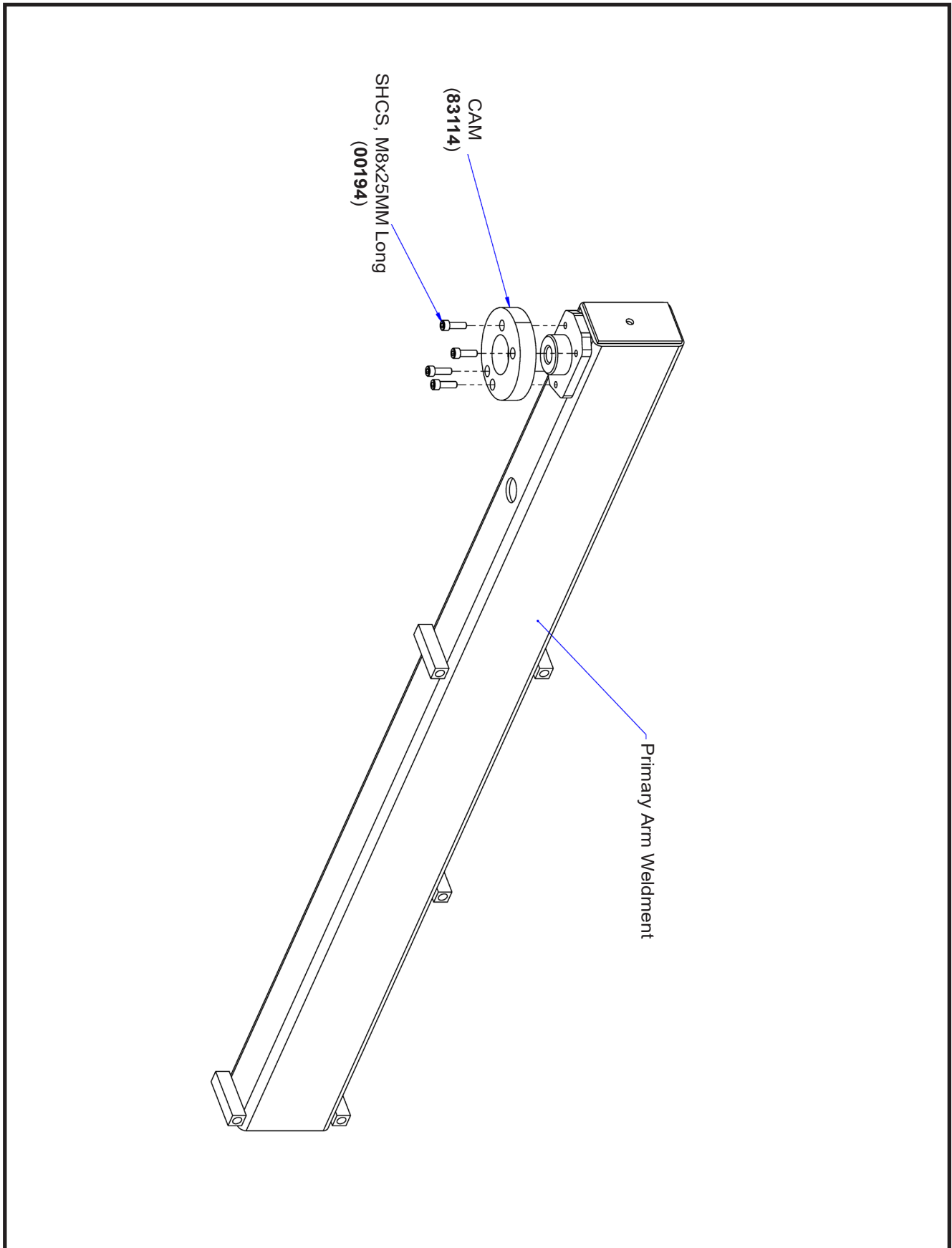

Mast Assembly 660 Only

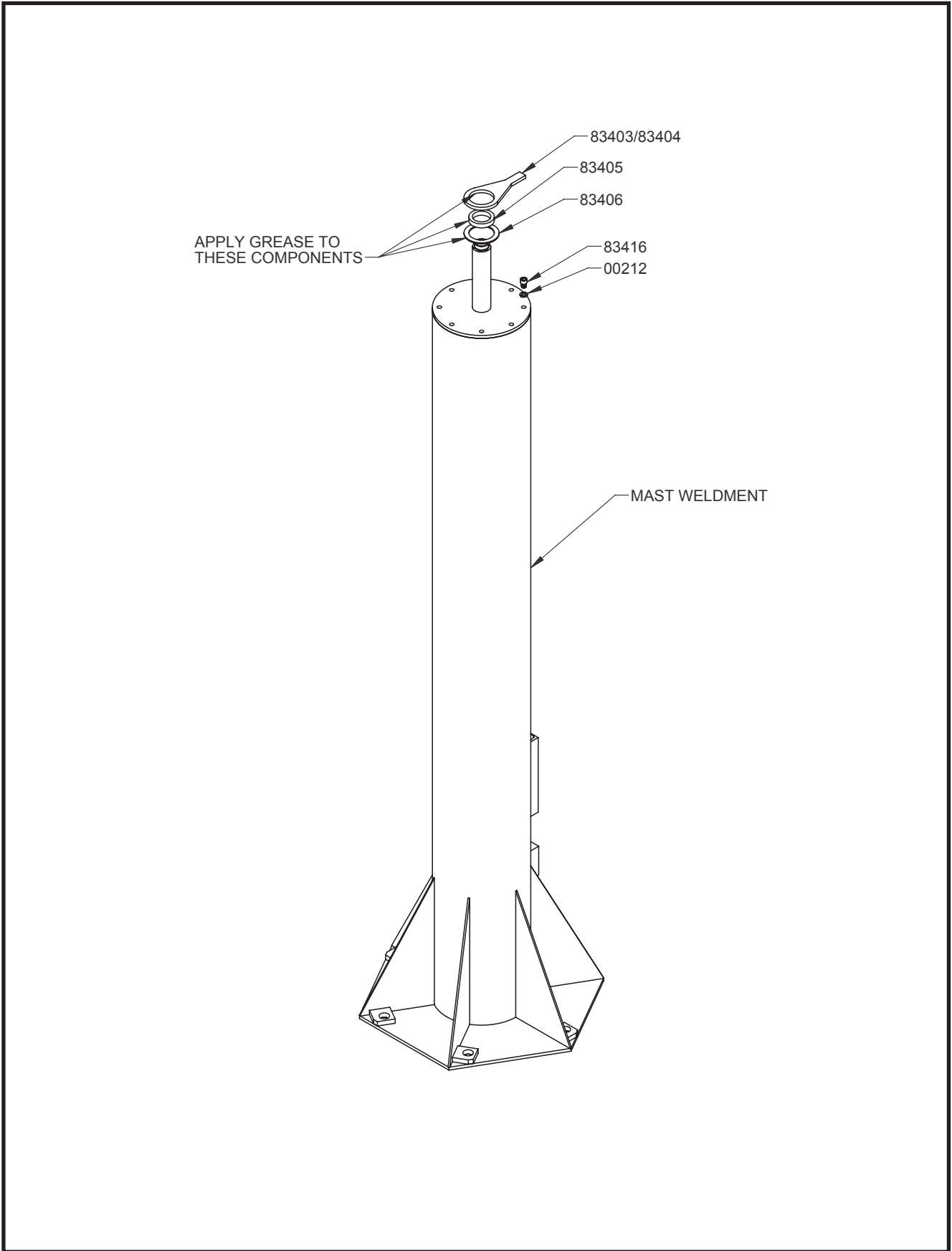

Arm Assembly 660 Only

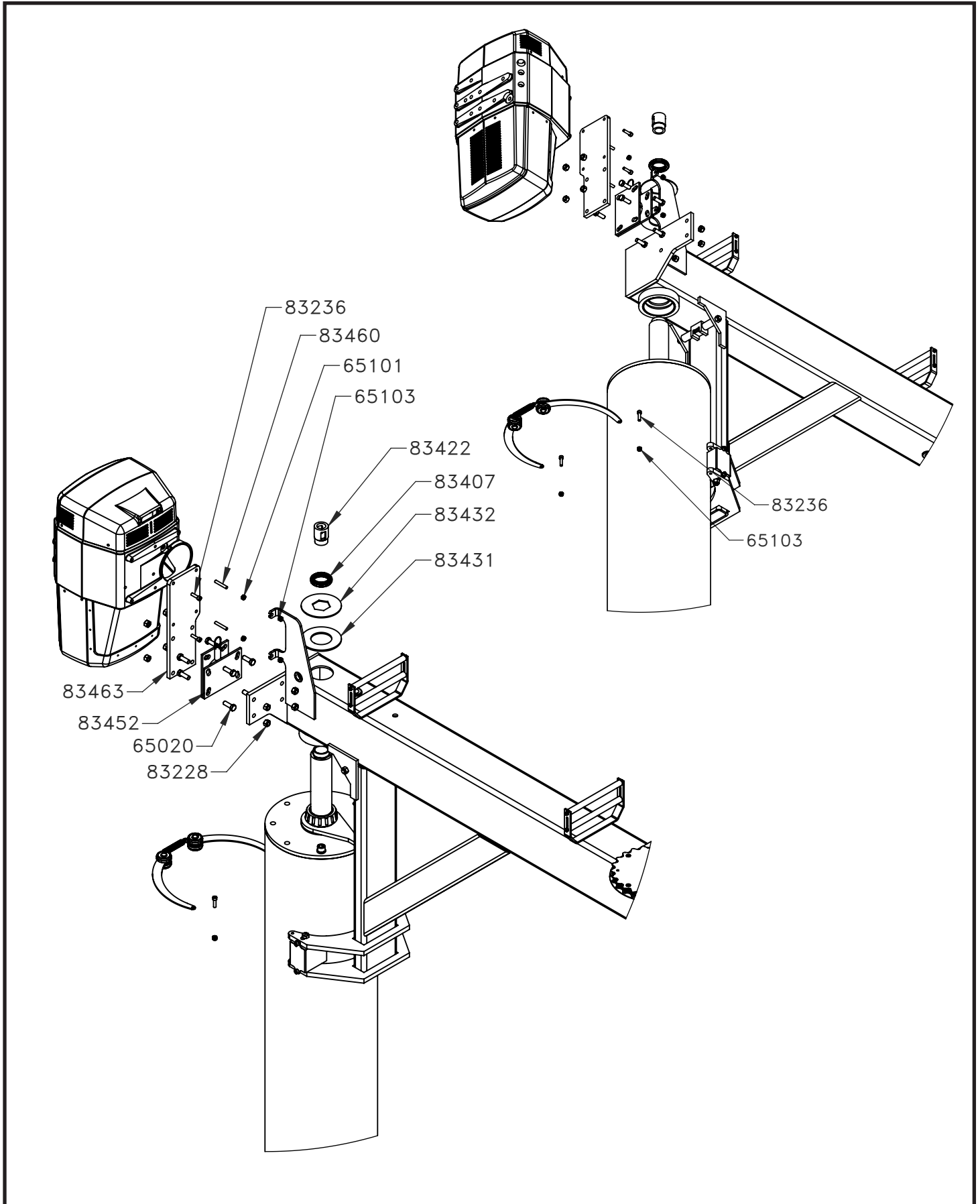

Primary Arm Assembly 660 Only

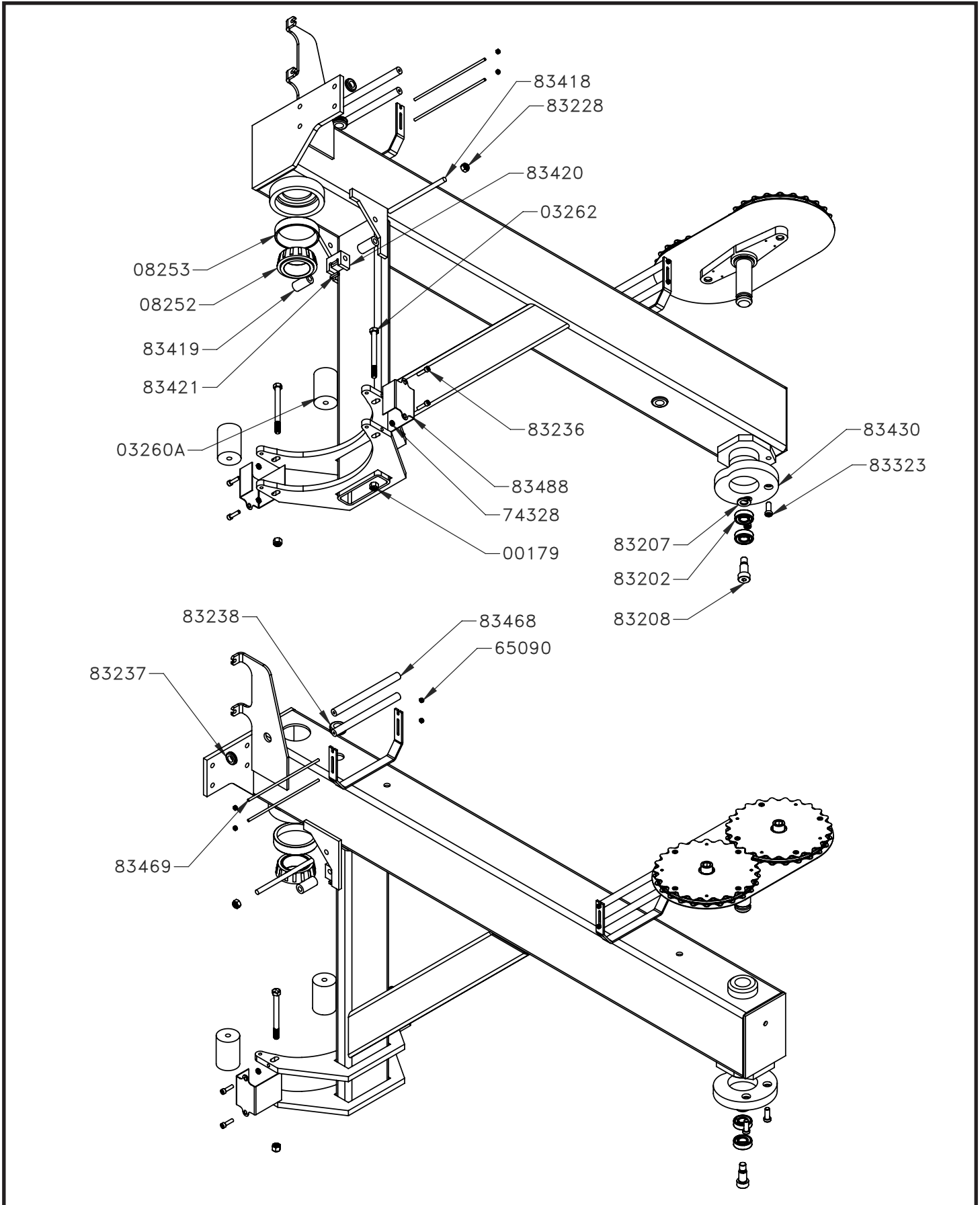

Secondary Arm Assembly 660 Only

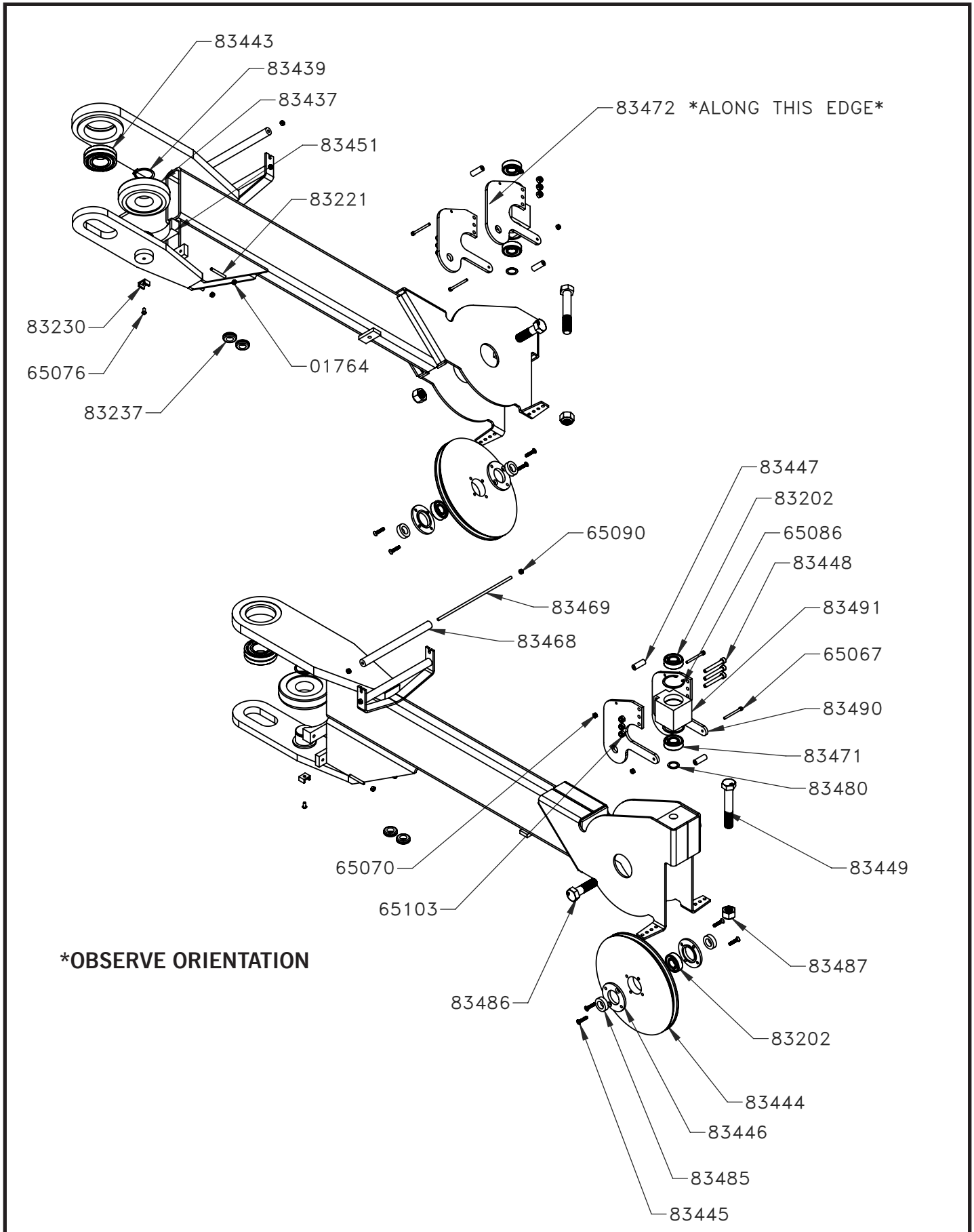

Knuckle Pulley Assembly 660 Only

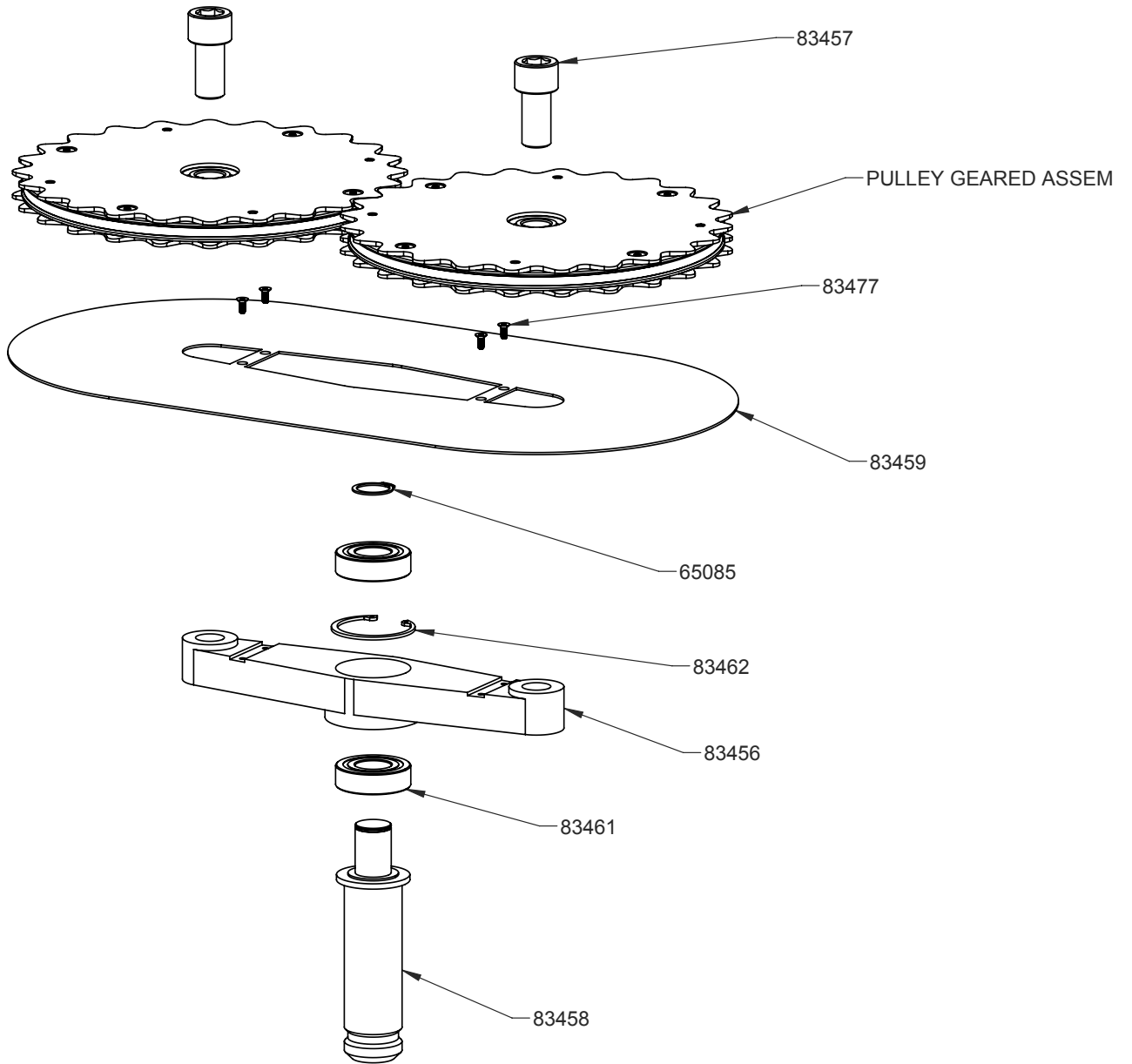

Pulley Geared Assembly
660 Only

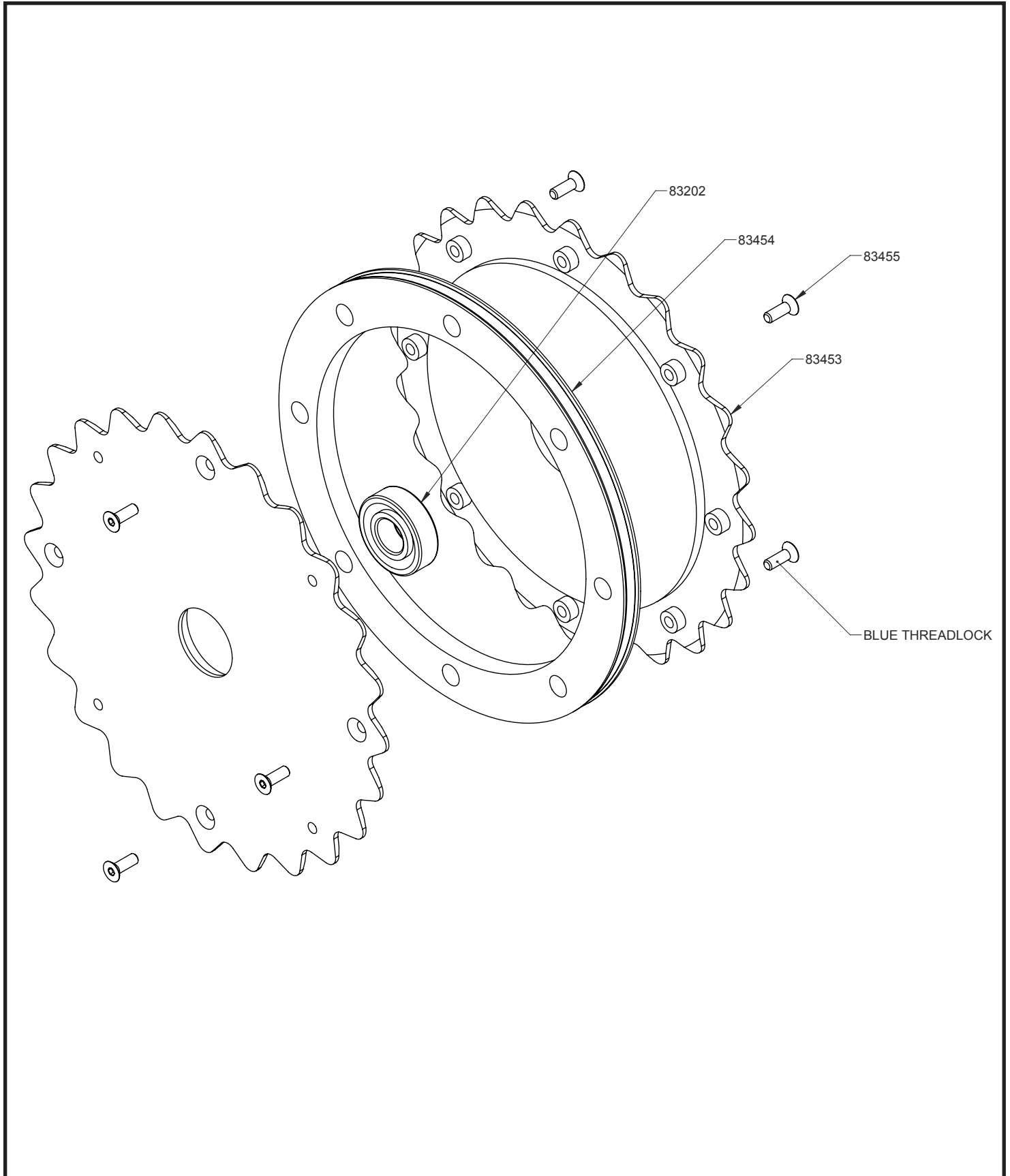

Chapter 10 - Recommended Tools and Parts

| Tool Name | Sizes |
|---|--|
| Metric Allen Wrenches (T-Type, 230mm long are preferred) | 2mm, 2.5mm, 3mm, 4mm, 5mm, 6mm, 8mm, 10mm |
| Metric Sockets (Drive sizes are typically 1/4 and 3/8 inch depending on socket size) | 5.5mm, 7mm, 8mm, 10mm, 19mm |
| Ratchet Handles and Extensions | User preference |
| Metric Combination Wrenches (10mm should be ratcheting type) | 10mm, 17mm, 19mm, 24mm |
| Lock Ring Pliers | small and medium sizes |
| Screwdrivers (flat and Phillips) | smaller precision type |
| Long Nose Pliers | 8 inch is typical |

| Gorbel Part Number | Spare Parts Kit |
|--------------------------------------|--|
| Level 1 G-Force.SpareParts.L1.Kit | Basic Kit: Wire Rope + Coil Cord or Pendant Cable |
| Level 2 G-Force.SpareParts.L2.Kit | Basic Kit plus: Hardware Kit |
| Level 3 G-Force.SpareParts.L3.Kit | All of the above plus: Swivel Kit |

Contact Inside Sales for specific part numbers and applications.

NOTE: Spare part kits can be ordered through CraneBrain / Intelligent Lifting Components / Accessories.

GORBEL®

A C L A S S A B O V E

600 Fishers Run, P.O. Box 593
Fishers, NY 14453-0593
Phone: (800) 821-0086
Fax: (800) 828-1808
E-Mail: info@gorbel.com
<http://www.gorbel.com>

© 2021 Gorbel Inc. All Rights Reserved

